



Operating instructions
Milling machines
CNC milling machines
 with dovetail guides

- | | | | |
|----------|-------------|----------|-------------|
| F1200 | F1200 hs | F1210 | F1210 hs |
| F1200-C | F1200-C hs | F1210-C | F1210-C hs |
| CC-F1200 | CC-F1200 hs | CC-F1210 | CC-F1210 hs |

WABECO
 MASCHINENMANUFAKTUR seit 1885

Please read before putting into operation for the first time!

Every person that operates the machine, maintains or repairs it, must have read the operating instructions, and in particular, the safety notes prior to putting the machine into operation. Please store these documents for subsequent use.

Original version in German/translation in English
Status at 06/2018

Dear Customer!

With the purchase of the **WABECO machine** you have decided in favour of a quality tool. This machine has been manufactured with the greatest of care and subject to precise quality controls.

These operating instructions are designed to help your to use your new machine safely and correctly. For this reason, we ask you to read the appropriate notes through attentively and to take care to observe them.

After unpacking the tool, check whether any transportation damages have occurred. Complaints, whatever their nature, should be communicated immediately. Subsequent claims cannot be recognised.

For all queries and replacement part orders, **please always specify the machine number** (see type plate).

Reprinting and reproductions of any kind, even extracts, require the written permission of WABECO

Disposing of the machine

The transportation and protective packaging is made of the following materials:

- Corrugated card
- Polystyrene without Freon
- Polyethylene foil
- Timber as single-use pallet (untreated)
- Euro pallet (multiple use packaging)

If you no longer need the items, or you do not want to reuse them, dispose of these items at the officially recognised recycling points.

The machine is manufactured in such a way that 98% of the used materials that can be recycled, for example, steel, cast iron, aluminum and only 2% are chemical materials, e.g. cable sleeves of electrical cables, PCBs.

If you have any difficulties in disposing of these parts properly, we would be happy to help: with prior agreement we will take back the machine in full and dispose of it. You must, however, cover the costs of sending it to us.

wabeco-rs.de



Walter Blombach GmbH
42899 Remscheid
Am Blaffertsberg 13
Germany

Phone +49 2191 597-0
Fax +49 2191 597-42
E-Mail info@wabeco-remscheid.de

Index

	Declaration of conformity	8
	F1200 - F1200 hs - F1210 - F1210 hs	
	Declaration of conformity	9
	F1200-C - F1200-C hs - F1210-C - F1210-C hs	
	Declaration of conformity	10
	CC-F1200 - CC-F1200 hs - CC-F1210 - CC-F1210 hs	
1.	Important safety notes	11
1.1	Intended use	11
1.2	Improper and incorrect use	11
1.3	Modifications to the machine	11
1.4	Safety regulations for proper use	11
1.5	Safety features	14
1.5.1	For all milling machines	14
1.5.2	For milling machines for the installation of a CNC controller and for CNC milling machines	14
1.5.3	For CNC milling machines	14
1.6	Explanations of the symbols	15
2.	Delivery and set up	15
2.1	Transporting the machine	16
3.	Putting into operation	17
3.1	For all milling machines	17
3.2	For all CNC milling machines	17
3.2.1	Setting up and connecting the control computer	17
4.	Specifications regarding the machine	18
4.1	Identification of the model	18
4.2	F1200 - F1200 hs	18
4.2.1	Declaration of noise levels	18
4.2.2	Technical data	19
4.2.3	Dimensions of F1200 (1.4 kW)	20
4.2.4	Dimensions of F1200 hs (2.0 kW)	21
4.3	F1200-C - F1200-C hs	22
4.3.1	Declaration of noise levels	22
4.3.2	Technical data	23
4.3.3	Dimensions of F1200-C (1.4 kW)	24
4.3.4	Dimensions of F1200 hs (2.0 kW)	25
4.4	CC-F1200 - CC-F1200 hs	26
4.4.1	Declaration of noise levels	26
4.4.2	Technical data	27
4.4.3	Dimensions CC-F1200 (1.4 kW)	28
4.4.4	Dimensions CC-F1200 hs (2.0 kW)	29

Index

4.5	F1210 - F1210 hs	30
4.5.1	Declaration of noise levels	30
4.5.2	Technical data	31
4.5.3	Dimensions of F1210 (1.4 kW)	32
4.5.4	Dimensions of F1210 hs (2.0 kW)	33
4.6	F1210-C - F1210-C hs	34
4.6.1	Declaration of noise levels	34
4.6.2	Technical data	35
4.6.3	Dimensions of F1210-C (1.4 kW)	36
4.6.4	Dimensions of F1210-C hs (2.0 kW)	37
4.7	CC-F1210 - CC-F1210 hs	38
4.7.1	Declaration of noise levels	38
4.7.2	Technical data	39
4.7.3	Dimensions of CC-F1210 (1.4 kW)	40
4.7.4	Dimensions of CC-F1210 hs (2.0 kW)	41
4.8	Revolution setting	42
4.9	Electrical equipment 1.4 kW motor	43
4.10	Electrical equipment 2.0 kW motor	43
5.	Achieving optimum results and avoiding incorrect usage	43
6.	Installation and removal of collets	45
6.1	Installation	45
6.2	Removal	45
7.	Fitting and removing the tools	46
8.	Swiveling the milling head	48
9.	Drill stroke - depth stop	49
10.	Feed motions of the X-, Y- and Z-axes	50
11.	Adjustment of the spindle nuts with trapezoidal thread spindle	52
11.1	X- and Y-axes	52
11.2	Z-axis	53
12.	Adjustment of the dovetail guides	54
13.	Maintenance	55
14.	Lubrication of the machine	55
15.	Operational faults and the elimination of such	57
16.	Control elements	60
16.1	Milling machines F1200 - F1210 (1.4 kW)	60
16.2	Milling machines F1200 hs - F1210 hs (2.0 kW)	61
16.3	Milling machines F1200-C - F1210-C (1.4 kW)	62
16.4	Milling machines F1200-C hs - F1210-C hs (2.0 kW)	63

Index

16.5	CNC milling machines CC-F1200 - CC-F1210 (1.4 kW)	64
16.5.1	Switch cover on CNC machine control panel	65
16.6	CNC milling machines CC-F1200 - CC-F1210 (2.0 kW)	66
16.6.1	Switch cover on CNC machine control panel	67
17.	Drawings and legends	68
17.1	Protective hood	68
17.2	Electronic hood with 1.4 kW motor	70
17.2.1	F1200 - F1210 - F1200-C - F1210-C	70
17.2.2	CC-F1200 - CC-F1210	72
17.3	Milling machine head with 1.4 kW motor	74
17.4	Milling machine head with 2.0 kW motor	76
17.5	Z-column with vertical slide with trapezoidal thread spindle	80
17.6	Spindle Z-axis with trapezoidal thread spindle	82
17.6.1	F1200 - F1200 hs - F1210 - F1210 hs	82
17.6.2	F1200-C - F1200-C hs - F1210-C - F1210-C hs - CC-F1200 - CC-F1200 hs - CC-F1210 - CC-F1210 hs	84
17.7	Lateral drive for Z-axis with trapezoidal thread spindle	86
17.8	Cross-slide support with trapezoidal thread spindle	88
17.9	Spindle X-axis with trapezoidal thread spindle	90
17.9.1	F1200 - F1200 hs - F1210 - F1210 hs	90
17.9.2	F1200-C - F1200-C hs - F1210-C - F1210-C hs - CC-F1200 - CC-F1200 hs - CC-F1210 - CC-F1210 hs	92
17.10	Spindle Y-axis with trapezoidal thread spindle	94
17.10.1	F1200 - F1200 hs - F1210 - F1210 hs	94
17.10.2	F1200-C - F1200-C hs - F1210-C - F1210-C hs - CC-F1200 - CC-F1200 hs - CC-F1210 - CC-F1210 hs	96
17.11	Z-column with vertical slide with ball screw	98
17.12	Spindle Z-axis with ball screw	100
17.12.1	F1200 - F1200 hs - F1210 - F1210 hs	100
17.12.2	F1200-C - F1200-C hs - F1210-C - F1210-C hs - CC-F1200 - CC-F1200 hs - CC-F1210 - CC-F1210 hs	102
17.13	Lateral drive for Z-axis with ball screw	104
17.14	Cross-slide support with ball screw	106
17.15	Spindle X-axis with ball screw	108
17.15.1	F1200 - F1200 hs - F1210 - F1210 hs	108
17.15.2	F1200-C - F1200-C hs - F1210-C - F1210-C hs - CC-F1200 - CC-F1200 hs - CC-F1210 - CC-F1210 hs	110
17.16	Spindle Y-axis with ball screw	112
17.16.1	F1200 - F1200 hs - F1210 - F1210 hs	112
17.16.2	F1200-C - F1200-C hs - F1210-C - F1210-C hs - CC-F1200 - CC-F1200 hs - CC-F1210 - CC-F1210 hs	114

Index

17.17	Limit switch for X-axis	116
17.17.1	F1200-C - F1200-C hs - F1210-C - F1210-C hs - CC-F1200 - CC-F1200 hs - CC-F1210 - CC-F1210 hs	116
17.18	Limit switch for Y-axis	116
17.18.1	F1200-C - F1200-C hs - F1210-C - F1210-C hs - CC-F1200 - CC-F1200 hs - CC-F1210 - CC-F1210 hs	116
17.19	Limit switch for Z-axis	117
17.19.1	F1200-C - F1200-C hs - F1210-C - F1210-C hs - CC-F1200 - CC-F1200 hs - CC-F1210 - CC-F1210 hs	117
17.20	Machine control panel for 1.4 kW motor	118
17.21	Machine control panel for 2.0 kW motor	122
17.22	Support arm for machine control panel	126
17.23	Industrial monitor and membrane keyboard	128
17.23.1	Industrial monitor and membrane keyboard for 1.4 kW motor	130
17.23.2	Industrial monitor and membrane keyboard for 2.0 kW motor	132
17.24	Support arm for machine control panel with industrial monitor and membrane keyboard	134
18.	Circuit diagram	135
18.1	for 1.4 kW motor	135
18.2	for 1.4 kW motor and machine safety cabin	136
18.3	Industrial monitor and membrane keyboard for 1.4 kW motor	137
18.4	for 2.0 kW motor	138
18.5	for 2.0 kW motor and machine safety cabin	139
18.6	Industrial monitor and membrane keyboard for 2.0 kW	140
18.7	Stepper motor with limit switch	141
18.8	NC-rotary table	141
18.9	Legend for circuit diagrams	142
19.	Coolant unit (optional)	143
19.1	Setting up the coolant unit	143
19.2	Mounting of the coolant unit to the machine base cabinet (optional)	143
19.3	Mounting of the coolant return plate (optional)	144
19.4	Safety regulations for the handling of cooling lubricant	145
19.5	Filling the coolant unit	145
19.6	Operating the coolant unit without CNC controller	146
19.7	Operating the coolant unit with CNC controller	146
19.8	Positioning the segmented coolant hose	147
19.9	Controlling the flow of coolant using the coolant shut-off valve	147
19.10	Drawing and legend	148

Index

20.	Machine safety cabin (optional)	149
20.1	Setting up the machine safety cabin	149
20.2	Mounting of the machine safety cabin to the machine base cabinet (optional)	149
20.3	Safety regulations for the handling of cooling lubricant	150
20.4	Filling the coolant unit integrated in the machine safety cabin	150
20.5	Operating the coolant unit with CNC controller	150
20.6	Positioning the segmented coolant hose	150
20.7	Controlling the flow of coolant using the coolant shut-off valve	150
20.8	Drawing and legend	151
21.	Mounting bracket (optional)	152
21.1	Mounting the mounting bracket to the milling machine	152
21.2	Inserting the drive into the mounting bracket	153
21.3	Drawing and legend	153
22.	NC-rotary table (optional)	154
22.1	Clamping of workpieces on the NC-rotary table	154
22.2	Swiveling the worm shaft in and out	154
22.3	Setting the axial play of the NC-rotary table	155
22.4	Removing the NC drive unit	156
22.5	Setting the axial play of the worm shaft	157
22.6	Setting the axial play of the eccentric tappet	157
22.7	Drawing and legend	158

Declaration of conformity

We hereby declare, in the name of the manufacturer

Walter Blombach GmbH

**Werkzeug- und Maschinenfabrik
with headquarters in Remscheid und Neuerburg**

D-42871 Remscheid
D-54673 Neuerburg

Postfach 12 01 61
WABECO Str. 1-10

Telephone: (02191) 597-0
Telephone: (06564) 9697-0

Fax: (02191) 597-42
Fax: (06564) 9697-25

that the following named

Universal boring and milling machine

Type:

F1200 - F1200 hs

F1210 - F1210 hs

in the serial version, meets the following relevant regulations

- **EU Machine Directive 2006/42 EG**
- **EMC Directive 2014/30/EU**
- **EU Low Voltage Directive 2014/35/EU**

In order to fulfil/implement the requirements of the directives named above, the already published and applicable standards were drawn upon:

EN ISO 12100:2010
DIN EN 60204-1:2007
DIN EN 13128:2009

Proxy for the compilation of the technical documentation is the operational head of the above named manufacturer, Mr Christoph Schneider.

D-54673 Neuerburg 2018

Place and date of issue



Operational head Christoph Schneider

Declaration of conformity

We hereby declare, in the name of the manufacturer

Walter Blombach GmbH

**Werkzeug- und Maschinenfabrik
with headquarters in Remscheid und Neuerburg**

D-42871 Remscheid
D-54673 Neuerburg

Postfach 12 01 61
WABECO Str. 1-10

Telephone: (02191) 597-0
Telephone: (06564) 9697-0

Fax: (02191) 597-42
Fax: (06564) 9697-25

that the following named

CNC milling machine

Type:

F1200-C - F1200-C hs

F1210-C - F1210-C hs

in the serial version, meets the following relevant regulations

- **EU Machine Directive 2006/42 EG**
- **EMC Directive 2014/30/EU**
- **EU Low Voltage Directive 2014/35/EU**

In order to fulfil/implement the requirements of the directives named above, the already published and applicable standards were drawn upon:

EN ISO 12100:2010
DIN EN 60204-1:2007
DIN EN 13128:2009

Proxy for the compilation of the technical documentation is the operational head of the above named manufacturer, Mr Christoph Schneider.

D-54673 Neuerburg 2018

Place and date of issue



Operational head Christoph Schneider

Declaration of conformity

We hereby declare, in the name of the manufacturer

Walter Blombach GmbH

**Werkzeug- und Maschinenfabrik
with headquarters in Remscheid und Neuerburg**

D-42871 Remscheid
D-54673 Neuerburg

Postfach 12 01 61
WABECO Str. 1-10

Telephone: (02191) 597-0
Telephone: (06564) 9697-0

Fax: (02191) 597-42
Fax: (06564) 9697-25

that the following named

CNC milling machine

Type:

CC-F1200 - CC-F1200 hs

CC-F1210 - CC-F1210 hs

in the serial version, meets the following relevant regulations

- **EU Machine Directive 2006/42 EG**
- **EMC Directive 2014/30/EU**
- **EU Low Voltage Directive 2014/35/EU**

In order to fulfil/implement the requirements of the directives named above, the already published and applicable standards were drawn upon:

EN ISO 12100:2010
DIN EN 60204-1:2007
DIN EN 13128:2009

Proxy for the compilation of the technical documentation is the operational head of the above named manufacturer, Mr Christoph Schneider.

D-54673 Neuerburg 2018

Place and date of issue



Operational head Christoph Schneider

1. Important safety notes

1.1 Intended use

The milling machines described in these operating instructions are designed for the processing of metal, plastic and timber only.

To ensure safe operation of the milling machines, the regulations set out in the chapter: „Safety regulations“ must be observed.

1.2 Improper and incorrect use

The milling machines described in these operating instructions have been developed and manufactured for the purpose named above. Walter Blombach GmbH accepts no responsibility for property damage and personal injury caused as a result of not intended and incorrect use of the milling machines.

1.3 Modifications to the machine

For reasons of safety, it is forbidden for the user to make modifications of any type to the milling machine.

Walter Blombach GmbH accepts no responsibility for property damage and personal injury caused as a result of any modifications to the milling machine by the user that have not expressly been authorised by the company.

1.4 Safety regulations for proper use

The machine may represent a source of danger if it is not used correctly. For this reason, it is important that the following safety regulations are read attentively and observed carefully.

Every person that operates the machine, maintains or repairs it, must have read the operating instructions, and in particular, the safety notes prior to putting the machine into operation.

In order to fulfil these requirements, these operating instructions must accompany the machine throughout its entire lifetime and be available for research.

In the event that the machine changes owners, the operating instructions must thus be passed on to the new owner along with the machine.

1. Important safety notes

1.4 Safety regulations for proper use

1. Only specially trained persons may operate the machine. The guarantee and warranty are voided if damages are caused by improper operation.
2. We remind you that no liability will be accepted for damages caused by not observing these operating instructions.
3. The operator of the machine is to ensure that at least one copy of the operating instructions is stored in the immediate vicinity of the machine and available to the people who work with the machine.
4. The operator is to ensure that the safety and danger notifications on the machine are observed and that the signs are kept in a legible state.
5. Do not work without goggles.
6. Wear close fitting clothing and, if you have long hair, wear a hair net. Do not wear loose fitting or loose items (ties, shirt sleeves, jewellery etc.).
7. Gloves may not be worn.
8. In the event of an emission noise level as of 80 dB (A) at the workplace, ear defenders must be worn.
9. The machine may not operate without supervision.
10. Secure your machine in such a way that it cannot be switched on by children. Persons who have not been trained may not operate the machine.
11. Before using the machine, make sure it is in good working condition. Pay special attention to any damage to the grounded plug or the electrical connections. Never operate the machine with a defective, crushed or exposed cable.
12. Plug the grounded plug into a suitable socket for the machine. The cable for the machine may only be connected to a safety socket or a connection box. Have the safety socket or connection box checked by an electrical specialist before hand.
13. The safety socket or connection box must be close enough to the machine that the power cable is not under strain.
14. When carrying out maintenance and cleaning work, the machine must be switched off and the grounded plug pulled out.
15. Set-up work is only to be carried out with the machine switched off.
16. Do not reach into the operating machine.

1. Important safety notes

1.4 Safety regulations for proper use

17. Always switch the machine off when you are not using it.
18. Remain with the machine until it has come to a standstill.
19. Only have repairs carried out by a qualified specialist! Repair work may only be carried out by persons who are qualified for the relevant repairs and who are familiar with the appropriate health and safety requirements.
20. Protect the machine from damp
21. Constantly check the machine for damages. Replace damaged parts only with original parts and have these replaced by a specialist. The guarantee and warranty is voided if accessories and replacement parts are use that are not designed for the machine.
22. To avoid insufficient lighting, we recommend setting up a light source that provides a value of at least 500 Lux at the tool's cutting edge.
23. Do not remove the generated shavings with your hand. Use the appropriate tools (hand-held sweeper, hook, brush).
24. Tools and workpieces may never be changed when the machine is running.
25. Workpieces must be secured in such a way that they are not moved from their position by the rotation of the boring or milling machine.
26. Workpieces must be secured by suitable fixtures e.g. prisms, machine vice etc..
27. Chuck keys or similar tools may not be attached to the machine to ensure that they cannot be caught by the spindle and thrown about.

1. Important safety notes

1.5 Safety features

1.5.1 For all milling machines

In order to enable you to work safely with our machines, we have incorporated the following safety mechanisms. These meet the relevant European safety requirements:

Protective hood

The protective hood is secured to the machine housing and is designed to prevent touching of the rotating tool spindle. The protective hood is constructed in such a way that the working height (depending on the dimensions of the workpiece and tool) can be adjusted. The protective hood can be swiveled to enable fast exchange of tools.

ON/OFF switch with under-voltage trigger

The ON/OFF switch is fitted with an under-voltage trigger, thus, in the event of a power failure, the machine does not switch itself back on automatically. This prevents risks caused by the unexpected motion of the tool spindle.

Emergency off switch

The emergency off switch acts to quickly stop the machine.

Overload protection

The machine is fitted with an overload protection feature. This overload protection feature switches the main drive motor off automatically when the machine is overloaded. The machine can only then be switched on after a waiting period.

1.5.2 For milling machines for the installation of a CNC controller and for CNC milling machines

Machine safety cabin (optional)

In CNC mode, the door to the machine safety cabin must be closed in order for the milling machine to work in CNC operation.

You can only work in CNC mode with the **doors closed**.

Work carried out in conventional mode is carried out with the door open. The mode switch must be switched to manual mode.

The main spindle can be switched on when the doors are closed or open.

Working in CNC mode without machine safety cabin may pose a serious risk to the machine operator and cause serious accidents.

1.5.3 For CNC milling machines

Switch for operating modes

The mode switch has 3 settings (CNC mode – Idle position – Manual mode) that can only be selected with a key. After selecting the mode, the key can be removed in order to prevent a switching of the mode type by unauthorised persons.

1. Important safety notes

1.6 Explanations of the symbols



In the event of an emission noise level as of 80 dB (A) at the workplace, ear defenders must be worn.



Caution:

Always pull the power plug prior to any maintenance work!

Read the operating instructions prior to initial operation or maintenance work!



Caution:

Dangerous electric voltage!

2. Delivery and set up

The machine is packed with care at the factory.

The following should be checked after delivery:

1. Whether the packaging shows damages to be reported or
2. Whether the machine shows transportation damages to be reported. If this is the case, we ask you to communicate this information immediately. Subsequent claims cannot be recognised.

The boring and milling machine must be set up on a suitable, even and firm surface. **Suitable surfaces are, for example:**

- A machine base cabinet (available optionally)
- A separate workbench with a level surface (spirit level) that is strong enough to carry the weight of the machine without bending.
- A steel plate with a level surface (spirit level)

The machine must be screwed securely to the surface it is set up on. There are holes in the base of the machine that are designed for this purpose. **Good working results and low-vibration operation can only be ensured when the prerequisites for fixture as set out above are maintained.**

2. Delivery and set up

The place of set up should be selected in such a way that

- There is sufficient lighting
- The electrical power supply with safety socket and earth are installed close enough to the machine that the power cable is not subject to any strain.
- The power cable should also be dimensioned in such a way that a multiple socket can be used, for example, to power a coolant unit.

2.1 Transporting the machine

We recommend three people to lift the machine, using the positions shown (1). In doing so, two people should hold the machine on the left and right of the upper skid, the third should hold and balance the machine at the end of the base plate.

Due to the weight of the machine it is advisable to lift the machine by crane, if this is possible. To lift, wrap suitable lashing (2) as shown around the head of the machine. Before lifting the machine, ensure that the milling head has been moved to the upper end position to prevent damage to the machine.

When lifting, pay attention to an ergonomic stance and sufficient safety!

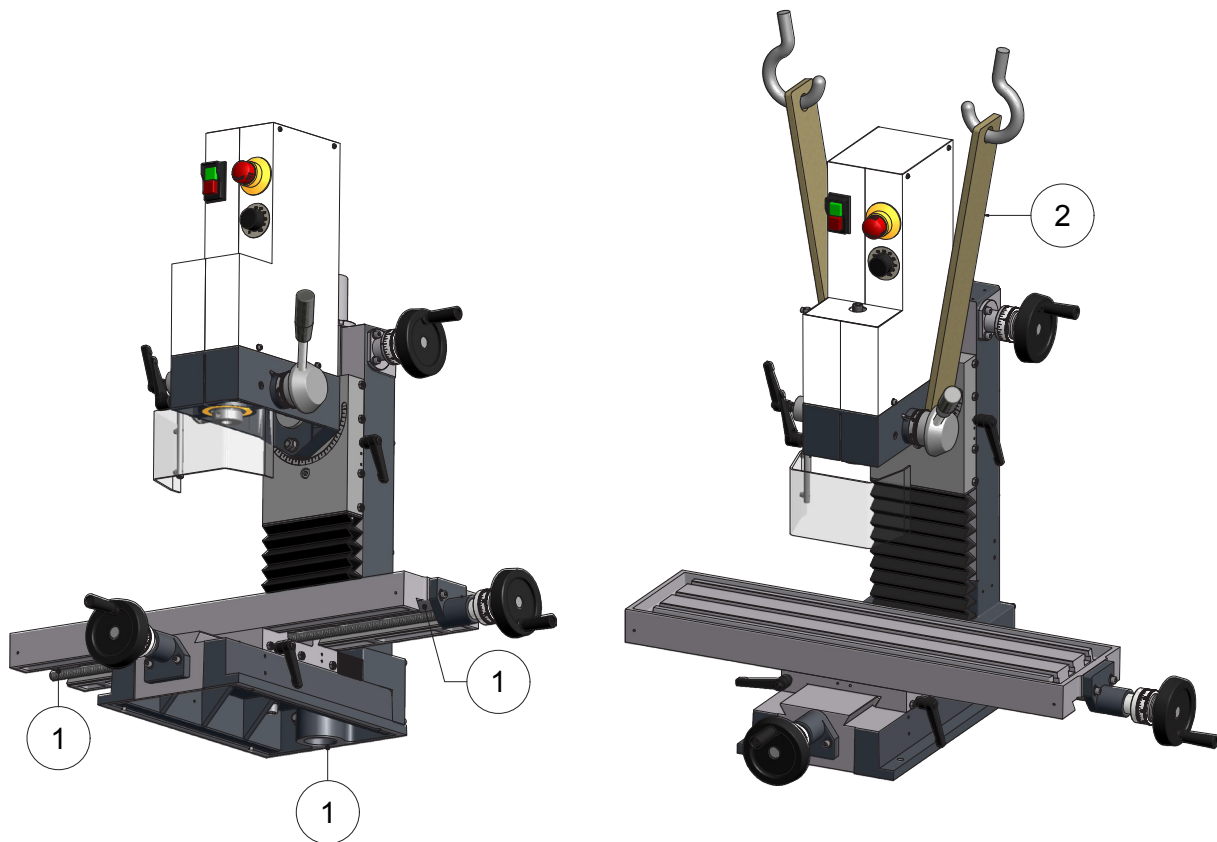

3. Putting into operation

3.1 For all milling machines

- Use a dry cloth to remove the corrosion protection that was applied to all exposed parts for transport
- In the event of marine impregnation of exposed parts, it is recommended you spray them with oil, allow it to work, and then remove the impregnation with a dry cloth.
- Once set up properly (see the section on delivery and set up) connect the grounded plug directly to a safety socket and the 230 V 50/60 Hz (optional 110 V 60 Hz) mains power supply.
- Provision of sufficient coolant for the operation of a coolant unit (optional)
- Release the axis clamps and check the individual need spindles for easy operation
- Check all electronic control elements, for example, ON/OFF switch, emergency off switch, potentiometer etc. for functionality.

3.2 For all CNC milling machines

When putting CNC machines into operation for the first time, always read the start-up manual.

3.2.1 Setting up and connecting the control computer

When selecting a suitable control computer, pay attention to the system prerequisites of the control software. These are listed on the rear of the CD case sent with the machine.

Follow the instructions in the start manual of the software to install the control software on the computer. The start manual can be found in the CD case of the control software included with the machine.

In the next step, the software must be adapted to your machine. To do this, follow the instructions sent with the machine which detail the editing of the parameters.

When the software has been successfully installed on the control computer and all parameters have been adapted successfully, the control computer must be connected with the machine controller.

The machine controller communicates with the computer via the serial interface (COM port). In order to establish a connection between the machine controller and the computer, connect the end of the interface cable that is on the machine console to the COM port of the computer.

CAUTION:

The axial cable of the step motors and the serial interface cable may only be plugged in or removed when the controller is switched off. Otherwise this may lead to damage to the controller, the machine or the control computer.

4. Specifications regarding the machine

4.1 Identification of the model

The precise model designation of your machine can be found on the type plate attached to the machine.

4.2 F1200 – F1200 hs

4.2.1 Declaration of noise levels

Noise emission declaration in accordance with DIN EN ISO 3744

Emission values in idle

	F1200	F1200 hs
Emission sound pressure level at the workplace		
at 50 %	= 66.8 dB (A)	= 74.8 dB (A)
at 100 %	= 66.7 dB (A)	= 76.4 dB (A)
Sound power level		
at 50 %	= 73.7 dB (A)	= 84.1 dB (A)
at 100 %	= 79.1 dB (A)	= 80.3 dB (A)



At an emission sound pressure level from 80 dB (A) and above at the workplace ear protection is required.

4. Specifications regarding the machine

4.2 F1200 – F1200 hs

4.2.2 Technical data

	F1200	F1200 hs
Working range		
Longitudinal travel X-axis	260 mm	
Vertical travel Z-axis	280 mm	
Transverse travel Y-axis	150 mm	
Drill stroke	55 mm	
Distance milling table - tool spindle	min. 100 mm max. 380 mm	
Outreach tool spindle - Z-column	185 mm	
Main drive motor		
Nominal voltage	230 V	
Nominal frequency	50/60 Hz	
Nominal performance of the spindle motor	1.4 kW	2.0 kW
Spindle revolutions, infinite	140 - 3000 rpm	100 - 7500 rpm
Machine precision		
True running accuracy of the tool spindle	0.01 mm	
Milling head		
Swiveling feature of milling head in both directions	90° (-90° to +90°)	
Tool spindle		
Tool holder	MT2 tightening thread M10 optional MT3 tightening thread M12 ISO30 DIN2080 tightening thread M12	
Work table		
	450 x 180 mm	
Number of T-slots	3	
Width of T-slots	12 mm	

4. Specifications regarding the machine

4.2 F1200 – F1200 hs

4.2.3 Dimensions of F1200 (1.4 kW)

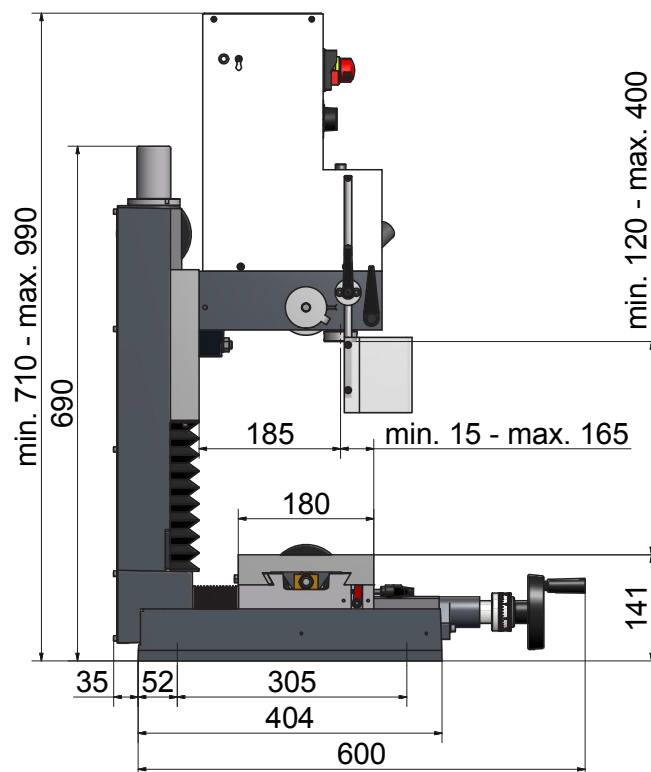
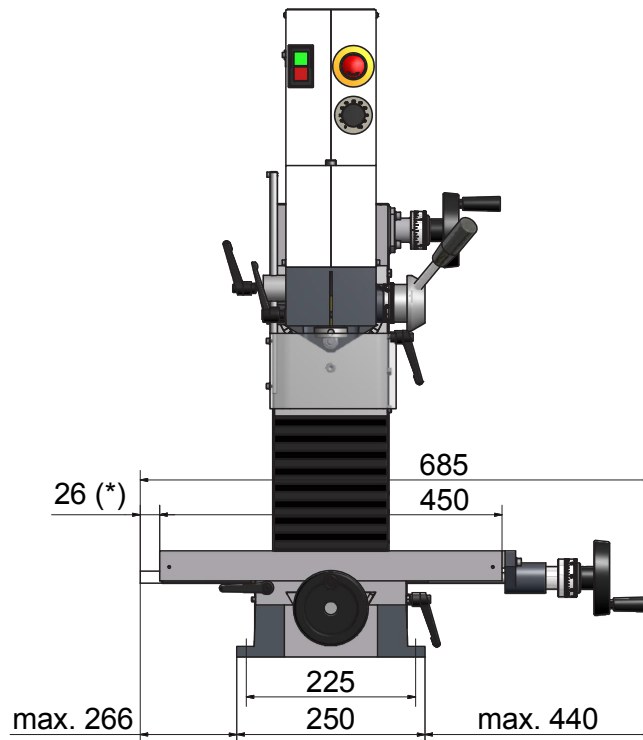

* only for ball screw

4. Specifications regarding the machine

4.2 F1200 – F1200 hs

4.2.4 Dimensions of F1200 hs (2.0 kW)

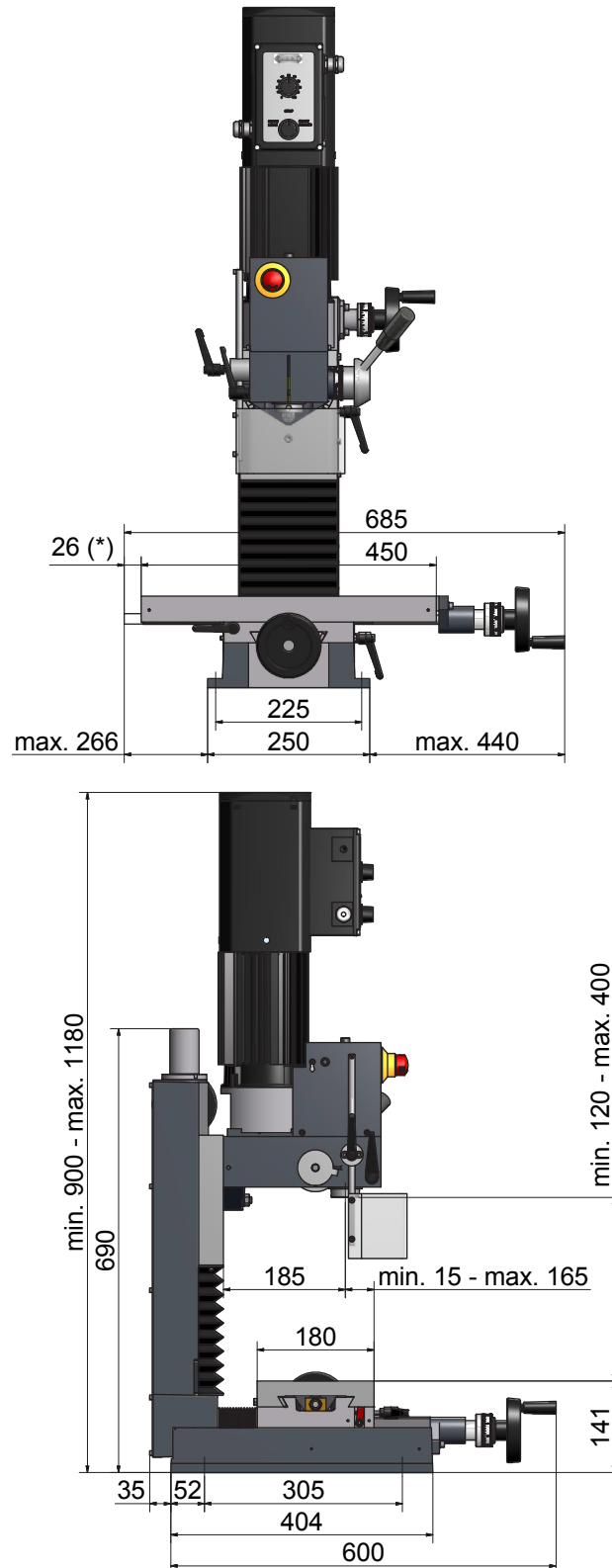

* only for ball screw

4. Specifications regarding the machine

4.3 F1200-C – F1200-C hs

4.3.1 Declaration of noise levels

Noise emission declaration in accordance with DIN EN ISO 3744

Emission values in idle

	F1200-C	F1200-C hs
Emission sound pressure level at the workplace		
at 50 %	= 66.8 dB (A)	= 74.8 dB (A)
at 100 %	= 66.7 dB (A)	= 76.4 dB (A)
Sound power level		
at 50 %	= 73.7 dB (A)	= 84.1 dB (A)
at 100 %	= 79.1 dB (A)	= 80.3 dB (A)



At an emission sound pressure level from 80 dB (A) and above at the workplace ear protection is required.

4. Specifications regarding the machine

4.3 F1200-C – F1200-C hs

4.3.2 Technical data

	F1200-C	F1200-C hs
Working range		
Longitudinal travel X-axis	260 mm	
Vertical travel Z-axis	280 mm	
Transverse travel Y-axis	150 mm	
Drill stroke	55 mm	
Distance milling table - tool spindle	min. 100 mm max. 380 mm	
Outreach tool spindle - Z-column	185 mm	
Main drive motor		
Nominal voltage	230 V	
Nominal frequency	50/60 Hz	
Nominal performance of the spindle motor	1.4 kW	2.0 kW
Spindle revolutions, infinite	140 - 3000 rpm	100 – 7500 rpm
Machine precision		
True running accuracy of the tool spindle	0.01 mm	
Milling head		
Swiveling feature of milling head in both directions	90° (-90° to +90°)	
Tool spindle		
Tool holder	MT2 tightening thread M10 optional MT3 tightening thread M12 ISO30 DIN2080 tightening thread M12	
Work table		
	450 x 180 mm	
Number of T-slots	3	
Width of T-slots	12 mm	

4. Specifications regarding the machine

4.3 F1200-C – F1200-C hs

4.3.3 Dimensions of F1200-C (1.4 kW)

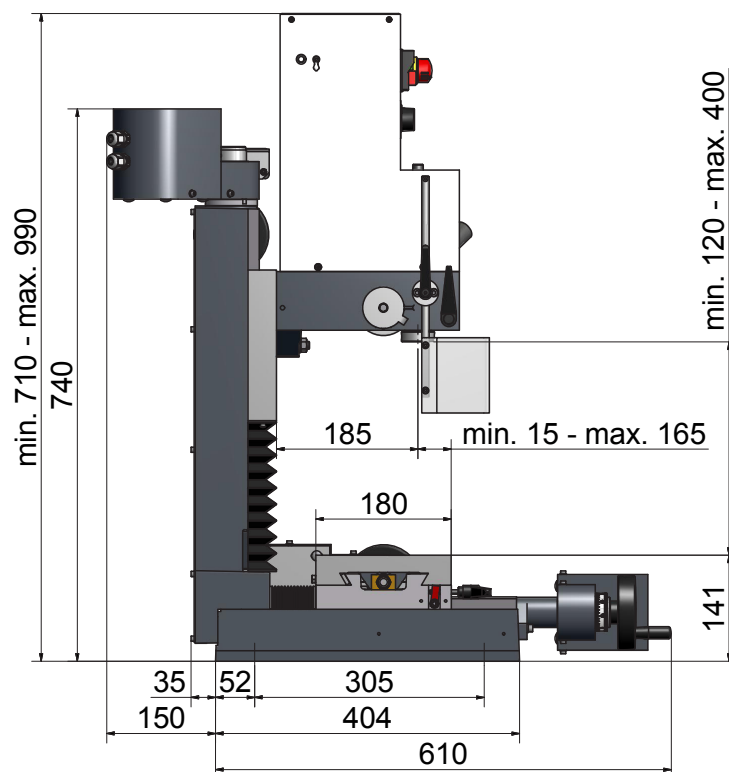
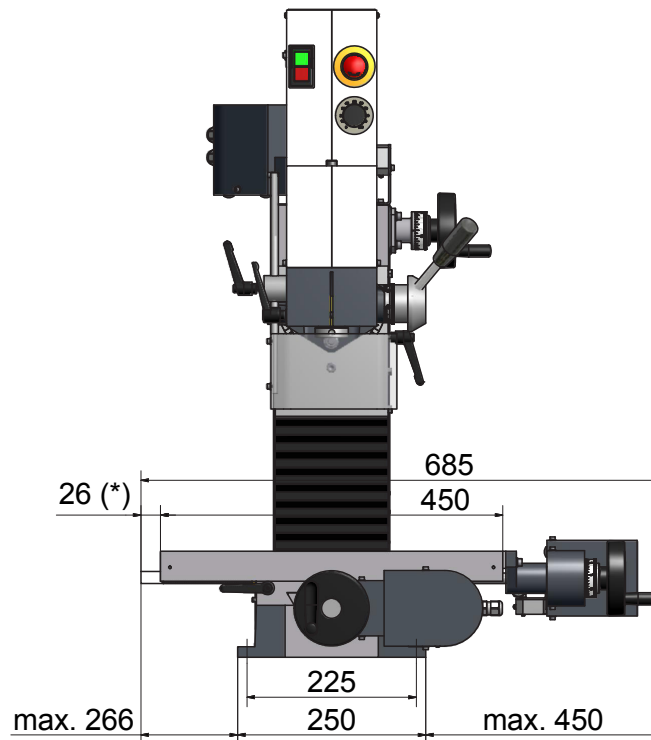

* for ball screw only

4. Specifications regarding the machine

4.3 F1200-C – F1200-C hs

4.3.4 Dimensions of F1200-C hs (2.0 kW)

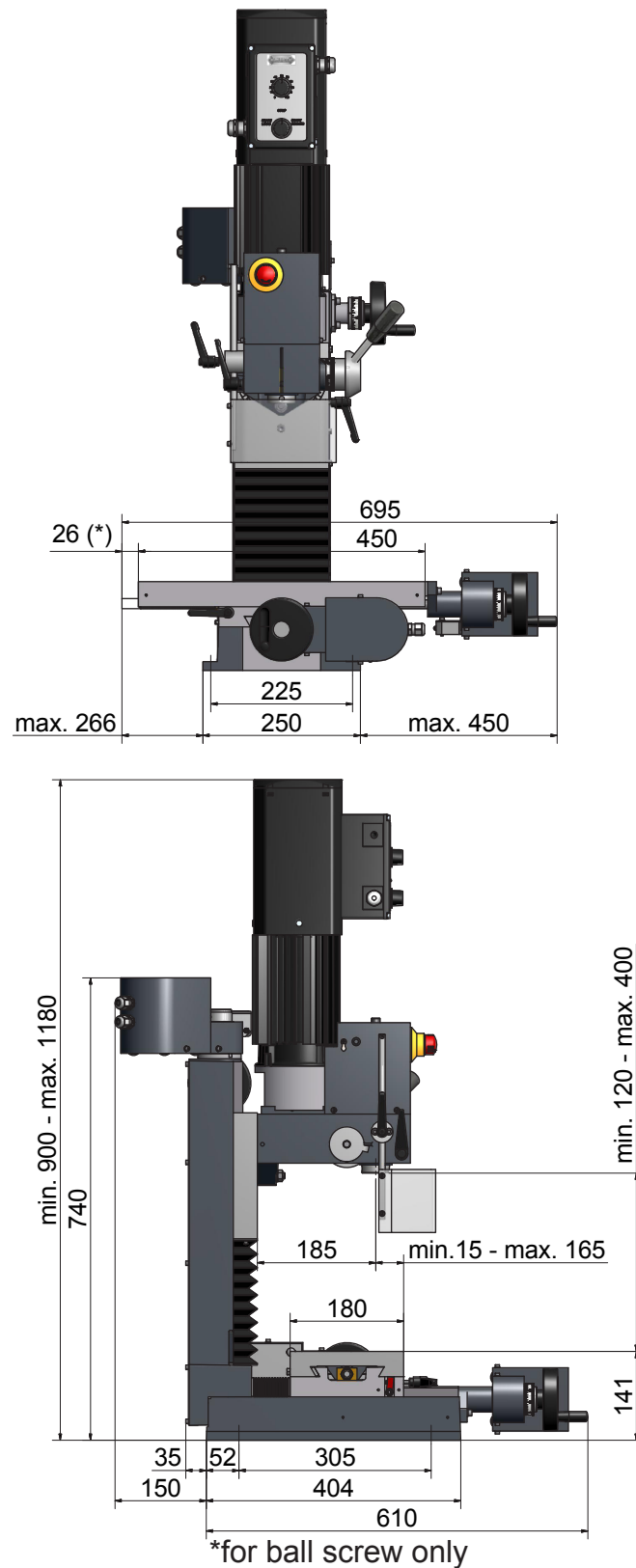

4. Specifications regarding the machine

4.4 CC-F1200 – CC-F1200 hs

4.4.1 Declaration of noise levels

Noise emission declaration in accordance with DIN EN ISO 3744

Emission values in idle

	CC-F1200	CC-F1200 hs
Emission sound pressure level at the workplace		
at 50 %	= 66.8 dB (A)	= 74.8 dB (A)
at 100 %	= 66.7 dB (A)	= 76.4 dB (A)
Sound power level		
at 50 %	= 73.7 dB (A)	= 84.1 dB (A)
at 100 %	= 79.1 dB (A)	= 80.3 dB (A)



At an emission sound pressure level from 80 dB (A) and above at the workplace ear protection is required.

4. Specifications regarding the machine

4.4 CC-F1200 – CC-F1200 hs

4.4.2 Technical data

	CC-F1200	CC-F1200 hs
Working range		
Longitudinal travel X-axis	260 mm	
Vertical travel Z-axis	280 mm	
Transverse travel Y-axis	150 mm	
Drill stroke	55 mm	
Distance milling table - tool spindle	min. 100 mm max. 380 mm	
Outreach tool spindle - Z-column	185 mm	
Main drive motor		
Nominal voltage	230 V	
Nominal frequency	50/60 Hz	
Nominal performance of the spindle motor	1.4 kW	2.0 kW
Spindle revolutions, infinite	140 - 3000 rpm	100 – 7500 rpm
Machine precision		
True running accuracy of the tool spindle	0.01 mm	
Milling head		
Swiveling feature of milling head in both directions	90° (-90° to +90°)	
Tool spindle		
Tool holder	MT2 tightening thread M10 optional MT3 tightening thread M12 ISO30 DIN2080 tightening thread M12	
Work table		
	480 x 180 mm	
Number of T-slots	3	
Width of T-slots	12 mm	
Positioning accuracy	± 0.015 mm	
Travel speed (rapid traverse)		
with nccad basic		
X- and Y-axes	30 – 600 mm/min	
Z-axis	30 – 400 mm/min	
with nccad professional		
X- and Y-axes	30 – 1200 mm/min	
Z-axis	30 – 800 mm/min	

4. Specifications regarding the machine

4.4 CC-F1200 – CC-F1200 hs

4.4.3 Dimensions of CC-F1200 (1.4 kW)

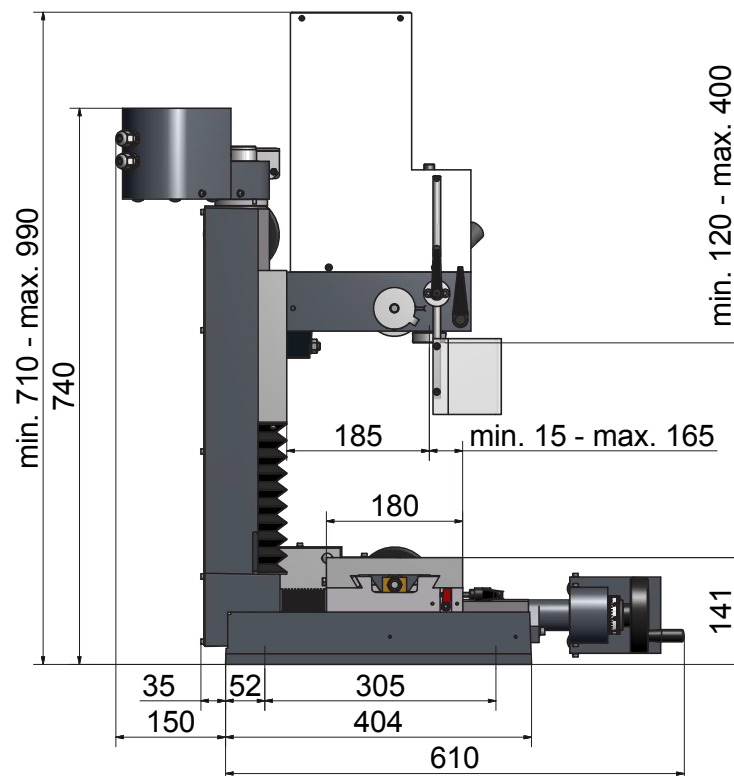
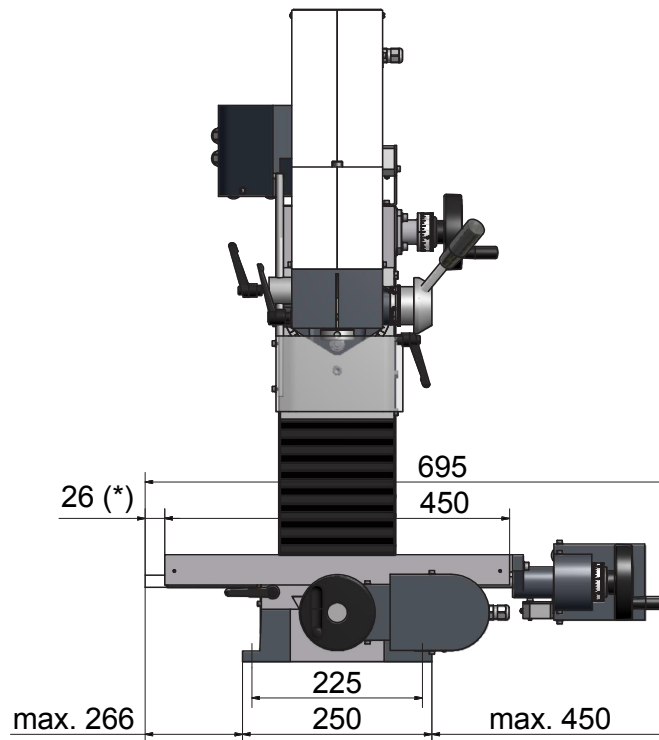

* for ball screw only

4. Specifications regarding the machine

4.4 CC-F1200 – CC-F1200 hs

4.4.4 Dimensions of CC-F1200 hs (2.0 kW)

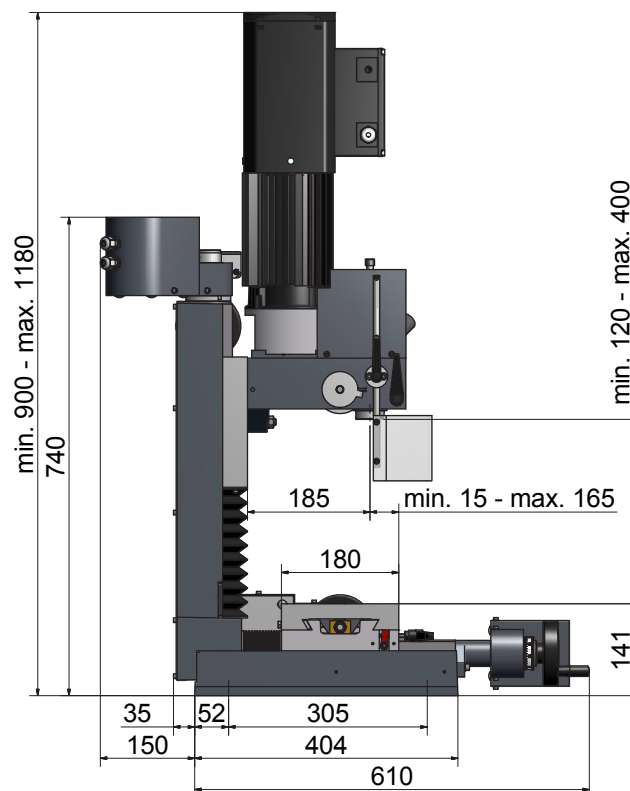
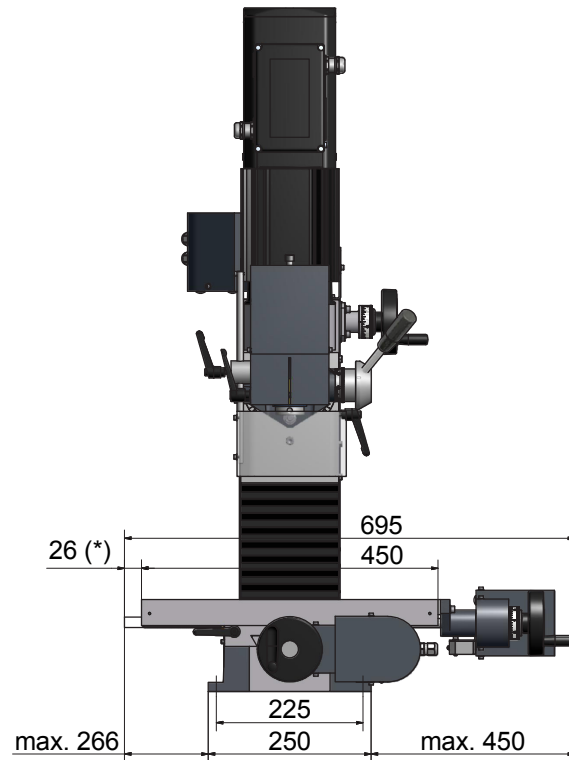

* for ball screw only

4. Specifications regarding the machine

The precise model designation of your machine can be found on the type plate attached to the machine.

4.5 F1210 – F1210 hs

4.5.1 Declaration of noise levels

Noise emission declaration in accordance with DIN EN ISO 3744

Emission values in idle

	F1210	F1210 hs
Emission sound pressure level at the workplace		
at 50 %	= 66.8 dB (A)	= 74.8 dB (A)
at 100 %	= 66.7 dB (A)	= 76.4 dB (A)
Sound power level		
at 50 %	= 73.7 dB (A)	= 84.1 dB (A)
at 100 %	= 79.1 dB (A)	= 80.3 dB (A)



At an emission sound pressure level from 80 dB (A) and above at the workplace ear protection is required.

4. Specifications regarding the machine

4.5 F1210 – F1210 hs

4.5.2 Technical data

	F1210	F1210 hs
Working range		
Longitudinal travel X-axis	500 mm	
Vertical travel Z-axis	280 mm	
Transverse travel Y-axis	150 mm	
Drill stroke	55 mm	
Distance milling table - tool spindle	min. 90 mm max. 370 mm	
Outreach tool spindle - Z-column	185 mm	
Main drive motor		
Nominal voltage	230 V	
Nominal frequency	50/60 Hz	
Nominal performance of the spindle motor	1.4 kW	2.0 kW
Spindle revolutions, infinite	140 - 3000 rpm	100 – 7500 rpm
Machine precision		
True running accuracy of the tool spindle	0.01 mm	
Milling head		
Swiveling feature of milling head in both directions	90° (-90° to +90°)	
Tool spindle		
Tool holder	MT2 tightening thread M10 optional MT3 tightening thread M12 ISO30 DIN2080 tightening thread M12	
Work table		
	700 x 180 mm	
Number of T-slots	3	
Width of grooves	12 mm	

4. Specifications regarding the machine

4.5 F1210 – F1210 hs

4.5.3 Dimensions of F1210 (1.4 kW)

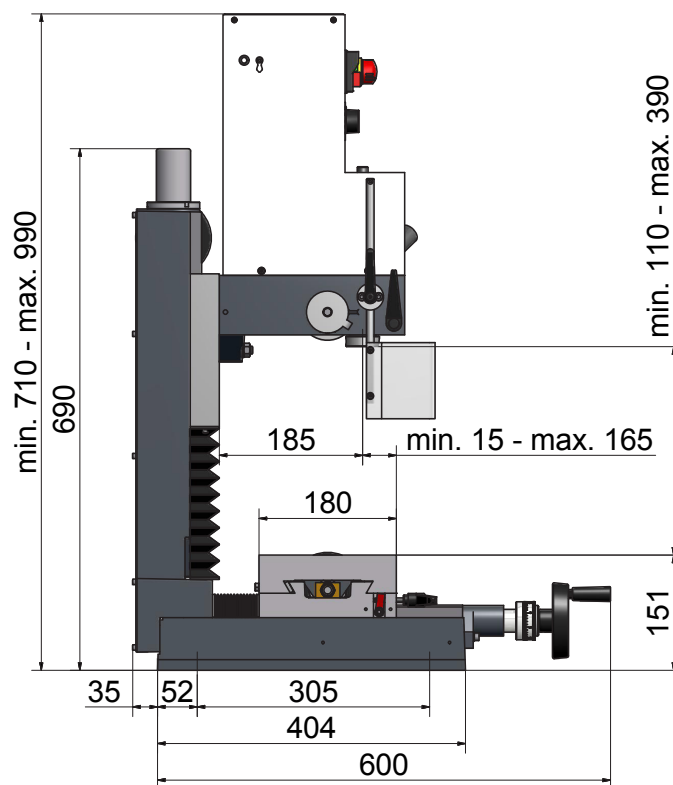
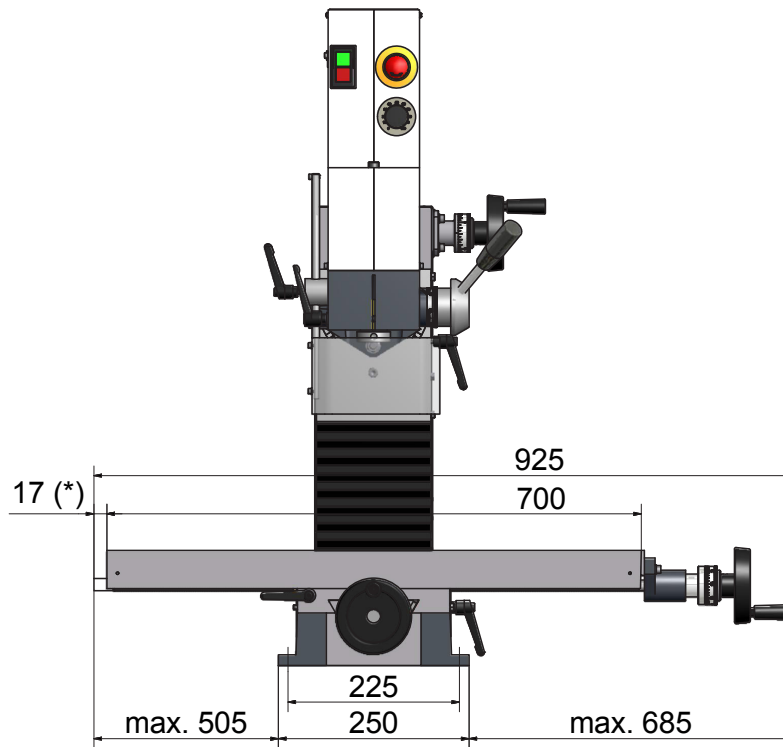

* only for ball screw

4. Specifications regarding the machine

4.5 F1210 – F1210 hs

4.5.4 Dimensions of F1210 hs (2.0 kW)

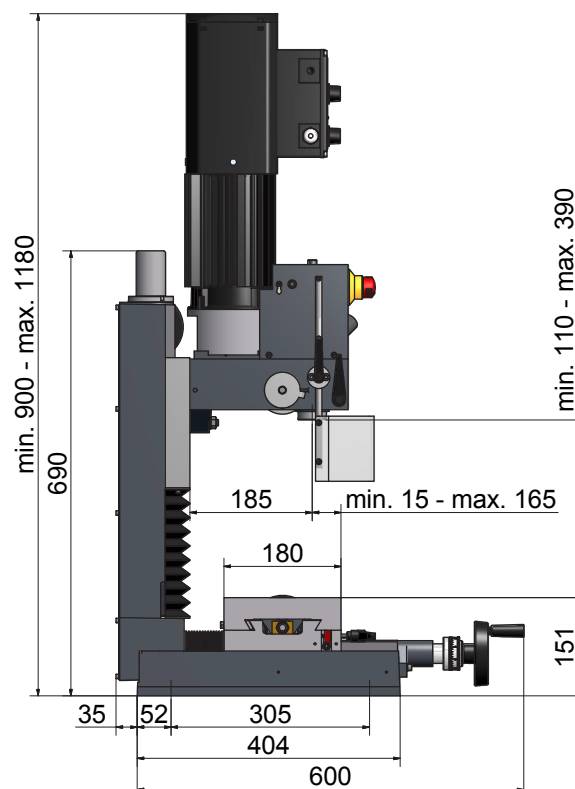
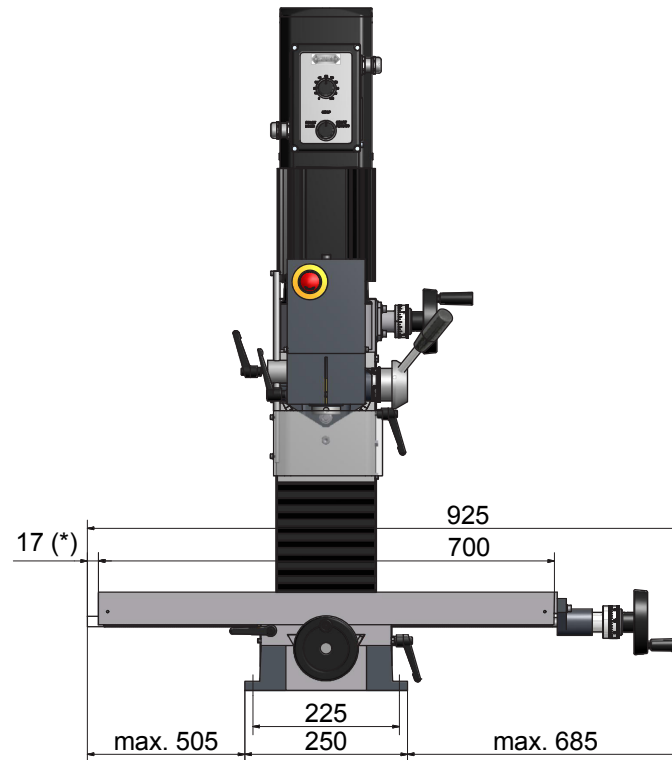

* only for ball screw

4. Specifications regarding the machine

4.6 F1210-C – F1210-C hs

4.6.1 Declaration of noise levels

Noise emission declaration in accordance with DIN EN ISO 3744

Emission values in idle

	F1210-C	F1210-C hs
Emission sound pressure level at the workplace		
at 50 %	= 66.8 dB (A)	= 74.8 dB (A)
at 100 %	= 66.7 dB (A)	= 76.4 dB (A)
Sound power level		
at 50 %	= 73.7 dB (A)	= 84.1 dB (A)
at 100 %	= 79.1 dB (A)	= 80.3 dB (A)



At an emission sound pressure level from 80 dB (A) and above at the workplace ear protection is required.

4. Specifications regarding the machine

4.6 F1210-C – F1210-C hs

4.6.2 Technical data

	F1210-C	F1210-C hs
Working range		
Longitudinal travel X-axis	500 mm	
Vertical travel Z-axis	280 mm	
Transverse travel Y-axis	150 mm	
Drill stroke	55 mm	
Distance milling table - tool spindle	min. 90 mm max. 370 mm	
Outreach tool spindle - Z-column	185 mm	
Main drive motor		
Nominal voltage	230 V	
Nominal frequency	50/60 Hz	
Nominal performance of the spindle motor	1.4 kW	2.0 kW
Spindle revolutions, infinite	140 - 3000 rpm	100 – 7500 rpm
Machine precision		
True running accuracy of the tool spindle	0.01 mm	
Milling head		
Swiveling feature of milling head in both directions	90° (-90° to +90°)	
Tool spindle		
Tool holder	MT2 tightening thread M10 optional MT3 tightening thread M12 ISO30 DIN2080 tightening thread M12	
Work table		
	700 x 180 mm	
Number of T-slots	3	
Width of T-slots	12 mm	

4. Specifications regarding the machine

4.6 F1210-C – F1210-C hs

4.6.3 Dimensions of F1210-C (1.4 kW)

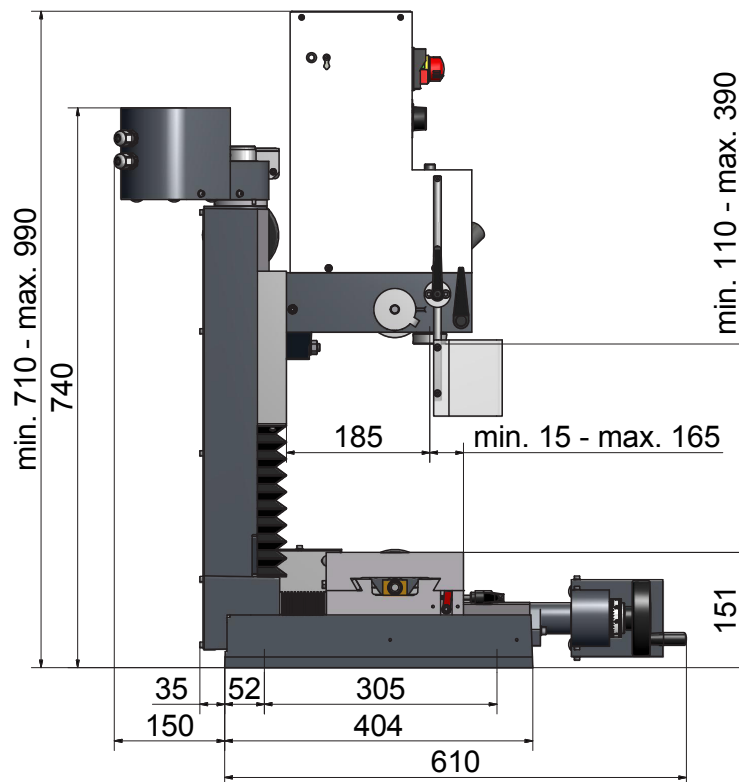
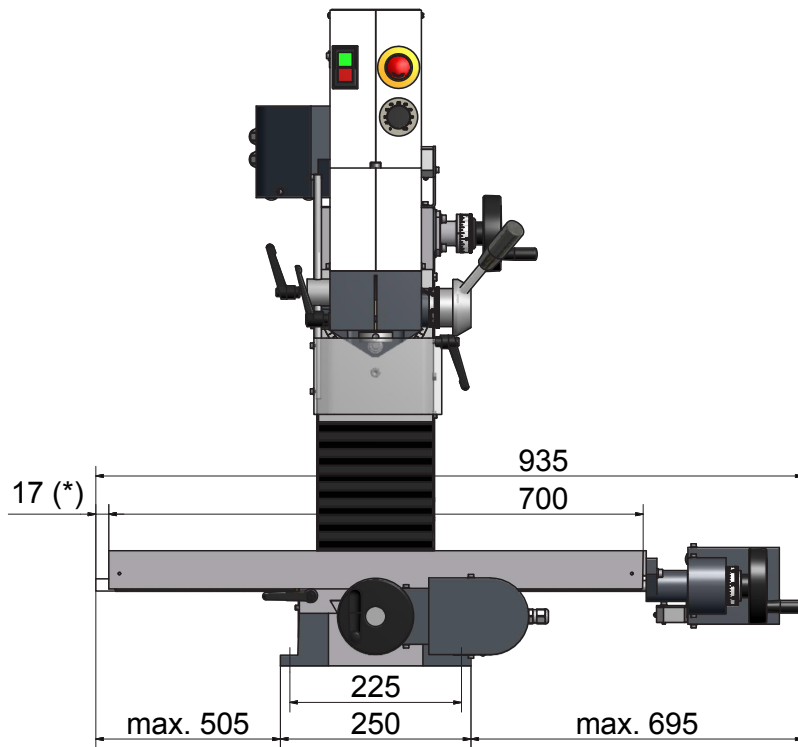

*for ball screw only

4. Specifications regarding the machine

4.6 F1210-C – F1210-C hs

4.6.4 Dimensions of F1210-C hs (2.0 kW)

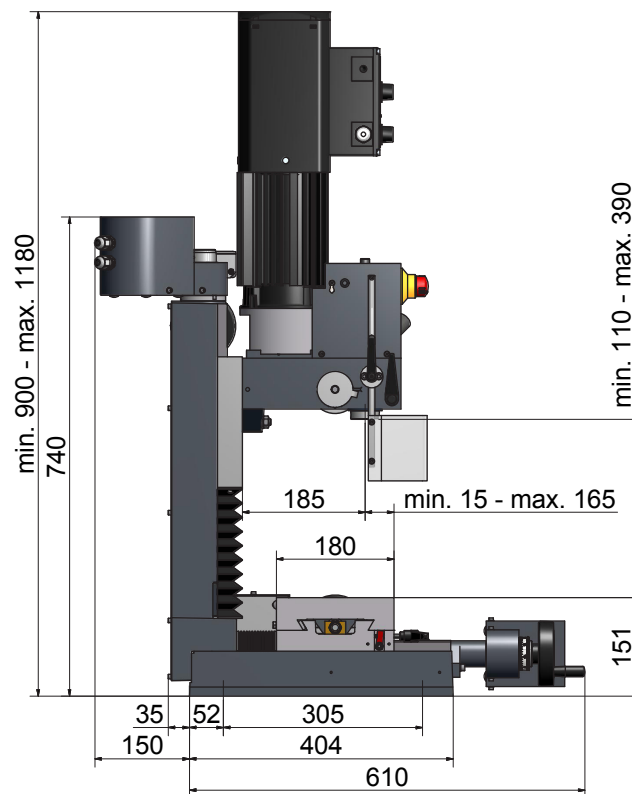
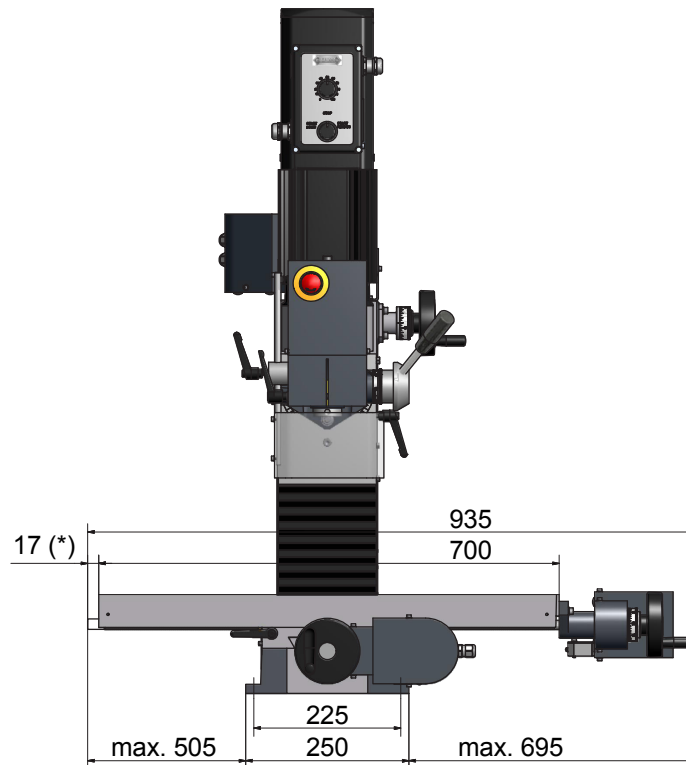

* for ball screw only

4. Specifications regarding the machine

4.7 CC-F1210 - CC-F1210 hs

4.7.1 Declaration of noise levels

Noise emission declaration in accordance with DIN EN ISO 3744

Emission values in idle

	CC-F1210	CC-F1210 hs
Emission sound pressure level at the workplace		
at 50 %	= 66.8 dB (A)	= 74.8 dB (A)
at 100 %	= 66.7 dB (A)	= 76.4 dB (A)
Sound power level		
at 50 %	= 73.7 dB (A)	= 84.1 dB (A)
at 100 %	= 79.1 dB (A)	= 80.3 dB (A)



At an emission sound pressure level from 80 dB (A) and above at the workplace ear protection is required.

4. Specifications regarding the machine

4.7 CC-F1210 - CC-F1210 hs

4.7.2 Technical data

	CC-F1210	CC-F1210 hs
Working range		
Longitudinal travel X-axis	500 mm	
Vertical travel Z-axis	280 mm	
Transverse travel Y-axis	150 mm	
Drill stroke	55 mm	
Distance milling table - tool spindle	min. 90 mm max. 370 mm	
Outreach tool spindle - Z-column	185 mm	
Main drive motor		
Nominal voltage	230 V	
Nominal frequency	50/60 Hz	
Nominal performance of the spindle motor	1.4 kW	2.0 kW
Spindle revolutions, infinite	140 - 3000 rpm	100 – 7500 rpm
Machine precision		
True running accuracy of the tool spindle	0.01 mm	
Milling head		
Swiveling feature of milling head in both directions	90° (-90° to +90°)	
Tool spindle		
Tool holder	MT2 tightening thread M10 optional MT3 tightening thread M12 ISO30 DIN2080 tightening thread M12	
Work table		
	700 x 180 mm	
Number of T-slots	3	
Width of T-slots	12 mm	
Positioning accuracy	± 0.015 mm	
Travel speed (rapid traverse)		
with nccad basic		
X- and Y-axes	30 – 600 mm/min	
Z-axis	30 – 400 mm/min	
with nccad professional		
X- and Y-axes	30 – 1200 mm/min	
Z-axis	30 – 800 mm/min	

4. Specifications regarding the machine

4.7 CC-F1210 - CC-F1210 hs

4.7.3 Dimensions of CC-F1210 (1.4 kW)

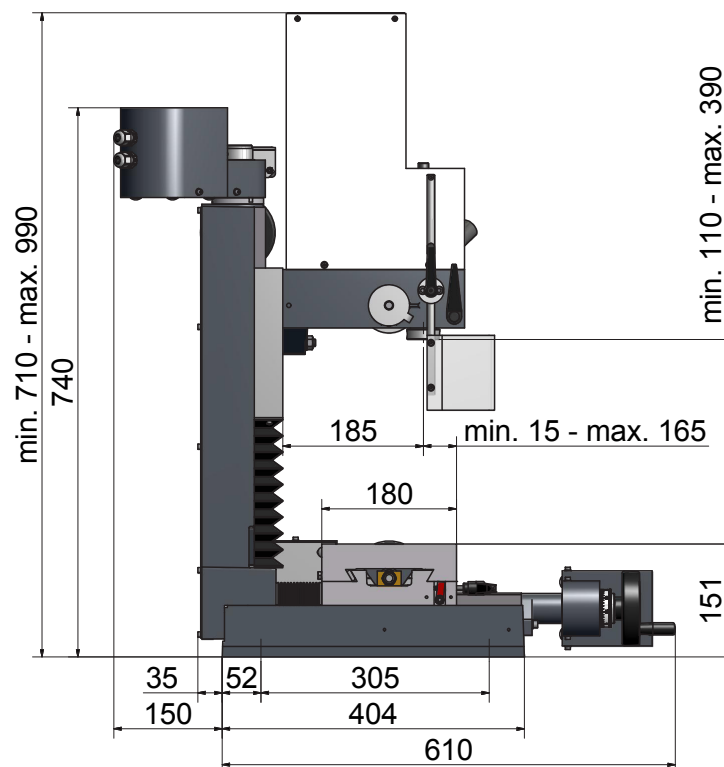
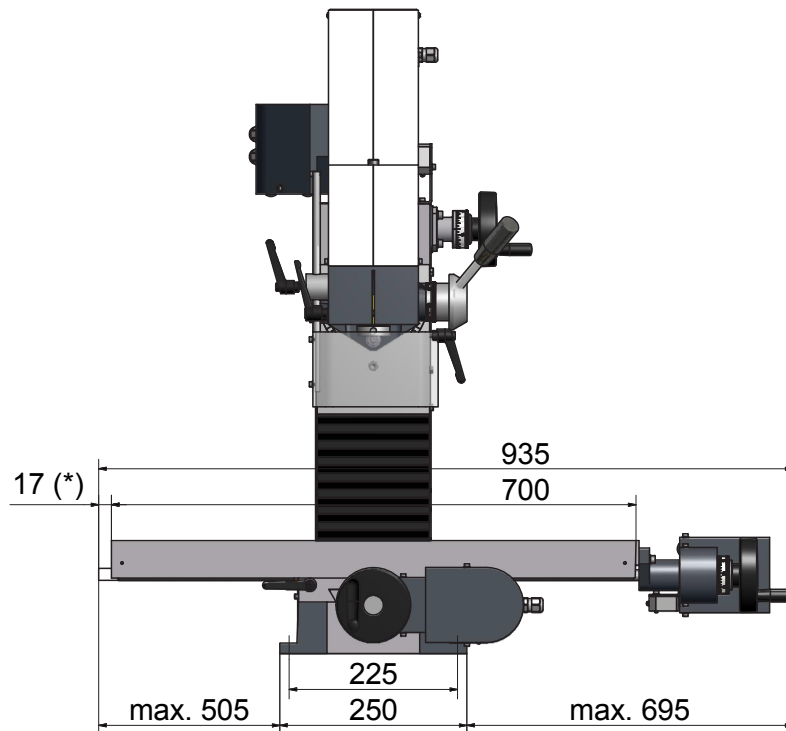

* for ball screw only

4. Specifications regarding the machine

4.7 CC-F1210 - CC-F1210 hs

4.7.4 Dimensions of CC-F1210 hs (2.0 kW)

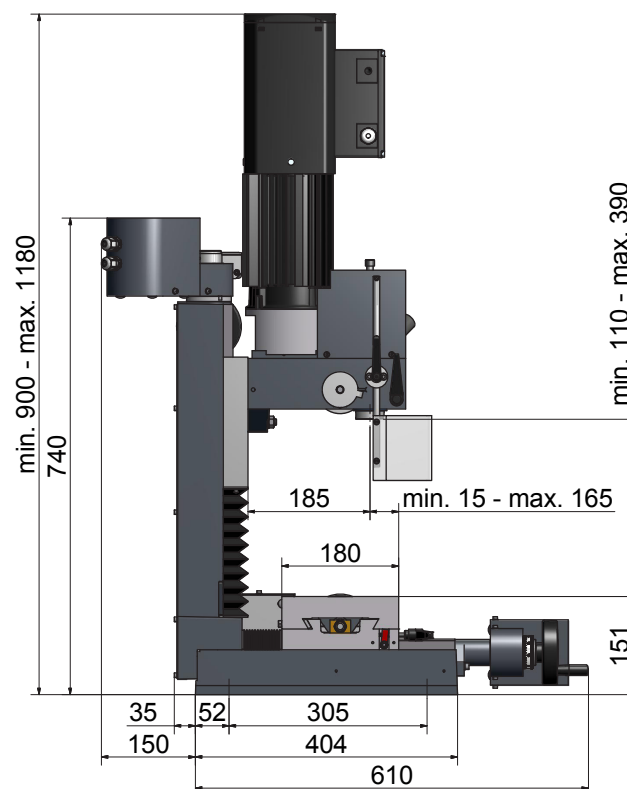
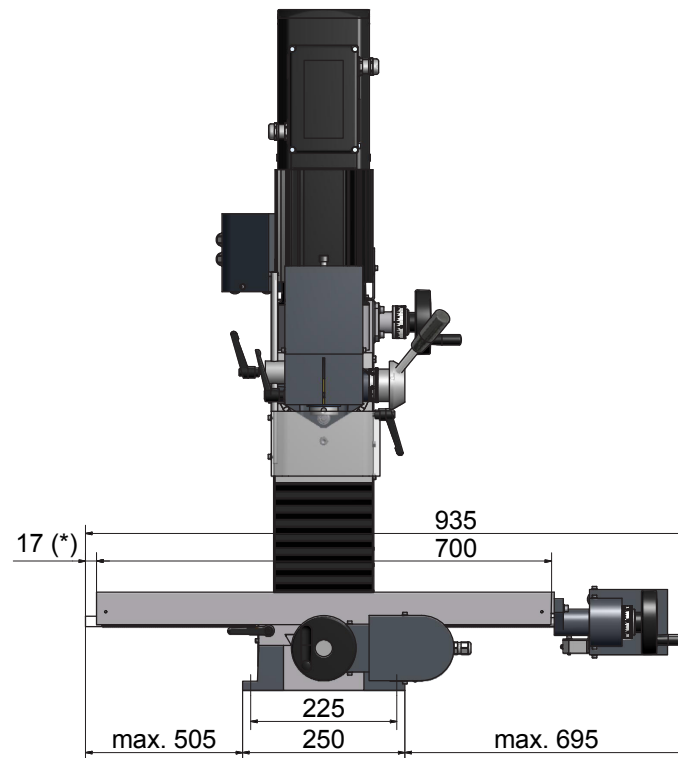

* for ball screw only

4. Specifications regarding the machine

4.8 Revolution setting

A certain cutting speed is required for milling, depending on the material (e.g. steel, aluminum).

In order to always be able to select a cutting speed adapted to the material of the workpiece and the milling machine diameter, the revolutions of the tool spindle can be infinitely set using the potentiometer. For the 1.4 kW motor, the infinite settings range from 140 to 3000 rpm, for the 2.0 kW motor, from 100 to 7500 rpm.

1.4 kW motor	
%	Revolutions rpm
1	140
5	140
10	150
15	160
20	200
25	300
30	400
35	700
40	850
45	1000
50	1200
55	1500
60	1900
65	2500
70	2800
80	3000
90	3000
100	3000

2.0 kW motor	
%	Revolutions rpm
2	50
3	100
4	200
5	350
10	700
15	1000
20	1400
25	1700
30	2100
35	2500
40	2900
45	3200
50	3600
55	4050
60	4500
65	4800
70	5200
75	5600
80	6050
85	6500
90	6900
95	7200
100	7500

4. Specifications regarding the machine

4.9 Electrical equipment 1.4 kW motor

The main drive motor (single phase series-wound motor) is supplied already installed

- The main spindle drive has an ON/OFF switch with under-voltage trigger.
- The ON/OFF switch must also be switched on again after the power is interrupted.
- In the event of the drive motor being overloaded, it will switch itself off automatically. The drive motor can only be switched back on again after a short waiting period.

4.10 Electrical equipment 2.0 kW motor

The frequency-regulated main drive motor is delivered already installed

- The machine has a 3-setting switch (START RIGHT - STOP - START LEFT).
- The under-voltage trigger is integrated in the electronics of the motor.
- In order to start the machine or restart after the power has been interrupted, first switch the 3-setting switch to the „STOP“ position.
- The switch must remain on „STOP“ for approximately 10 seconds to enable the motor to reset.
- To change the direction of rotation of the main drive motor, the switch must rest on „STOP“ for about 1 second to allow the relays on the control board enough time to switch.
- In the event of the main drive motor being overloaded, it will switch itself off automatically. The main drive motor can only be switched back on again after a short waiting period.

5. Achieving optimum results and avoiding incorrect usage

- Use of suitable processing tools.
- Adaptation of revolution setting and feed to the material and workpiece.
- Clamp the tool in such a way that the clamping point is as close to the workpiece as possible.
- Clamp the workpieces firmly and without vibrations.
- The use of coolant and lubrication to increase the durability of the tool, improve surface quality and accuracy.
- Clamp processing tools and workpieces on a clean clamping surface.
- Lubricate machine sufficiently.
- Set the bearing clearance and guides correctly.

5. Achieving optimum results and avoiding incorrect usage

It is recommended that:

- **The borer** should be fitted and tensioned with the key in such a way that the borer is positioned precisely between the three clamping jaws of the crown gear, quick clamping or collet chuck.
- **Clamp the milling machine with shaft** using the collet chuck and the appropriate collets.
- **Clamp the milling machine with bored hole** and longitudinal groove using the plugged milling machine spike.

When boring, attention is to be paid that:

- The appropriate revolutions are set according to the diameter of the borer.
- The pressure is gentle enough that the borer is able to cut without straining.
- In the event of too much pressure, the result is early borer wear or even borer breakage or jamming in the bored hole. **In the event of jamming, immediately bring the main drive motor to a stand-still by pressing the emergency off switch.**
- When using hard materials, for example, steel, ordinary boring oil must be used.
- The borer is always to be removed from the workpiece with the spindle rotating.
- When using non-metal materials, for example, wood, tearing on breakthrough can be prevented by clamping a piece of waste wood under the workpiece to be processed.
- For wood workpieces with a veneer or plastic coating, always work from the side with the veneer.
- With very thin sheets, also clamp using a piece of waste wood.

When milling, attention is to be paid that:

- The appropriate cutting speed is selected (see the section on revolution setting):
for materials with normal firmness values, e.g. steel 18-22 m/min.
for materials with higher firmness values 10-14 m/min.
- The pressure is to be selected so that the cutting speed remains constant.
- For hard materials, use ordinary boring oil.

When clamping the workpieces, attention should be paid that:

- The appropriate clamping screws are used for the T grooves of the milling machine table or use a machine vice.
- The milling machine table of the cross slide support is to be cleaned of dirt residue and shavings in order to ensure perfectly even clamping.

6. Installation and removal of collets

6.1 Installation

1. Place the collet on a flat surface.
2. Place the tensioning nut on the collet.
3. Press the tensioning nut down against the collet until it „clicks“.
4. The collet can now move freely in the central take-up shoulder and does not fall out when the collet is turned upside down.

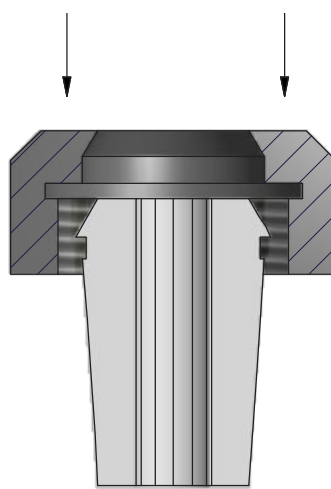

6.2 Removal

1. Hold the tensioning nut in one hand.
2. Press up against the collet.
3. The lateral pressure on the collet pushes this out of the take-up shoulder of the tensioning nut and it can now be removed from the nut.

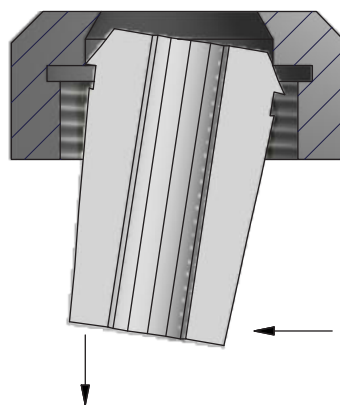

7. Fitting and removing the tools

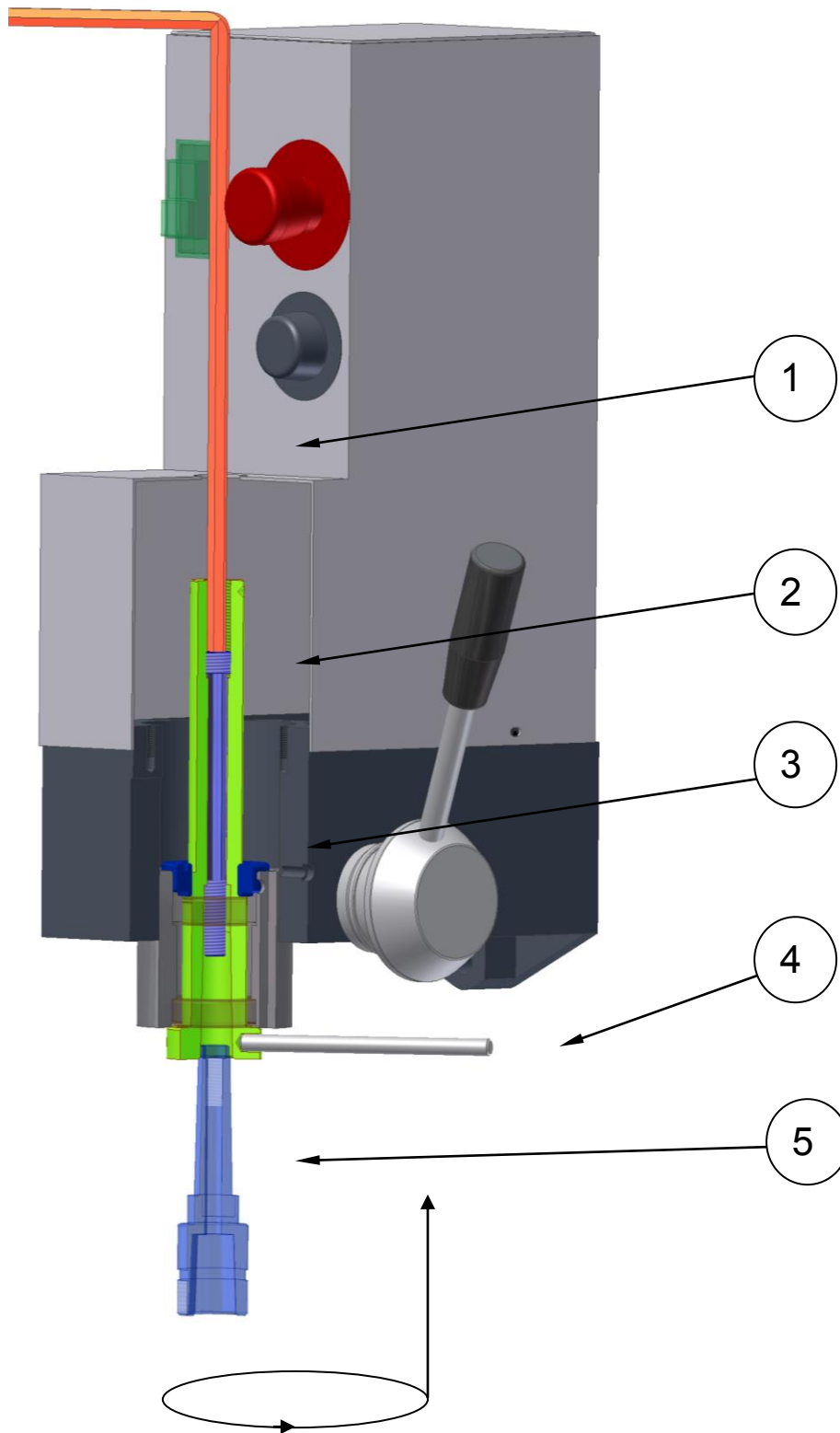

7. Fitting and removing the tools

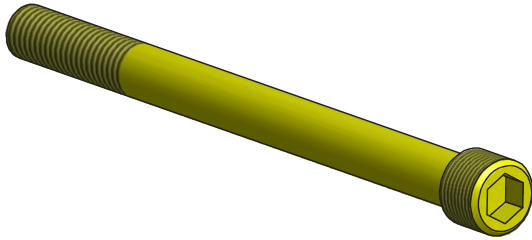

The **tool tightening and removing screw** has a fine thread at the head, and a coarse thread on the shaft. Due to this construction, a special procedure must be followed when fitting and removing tools.

To make this easier to understand, the image shows a cut-away of the protective hood and the spindle housing. The cross-section shows the tool screw (2) and the Allen key (1).

To change the tool, proceed as follows:

Tensioning tools with inner thread

1. Screw the tool tightening screw (2) clockwise using the Allen key (1) into the main spindle up to the end of the thread.
2. When the tool tightening screw (2) is at the end of the thread, undo by 2 - 3 turns.
3. Now the tool (e.g. the collet chuck (5)) is inserted by hand from below into the ball of the tool spindle (3) and screwed anti-clockwise onto the tool tightening screw (2). The Allen key (1) is used to hold the tool tightening screw (2) in place.
4. When the tool has been hand-tightened, the holding bolt (4) is used to hold the tool spindle (3) and tighten the tool tightening screw (2) clockwise without great strength using the Allen key (1).

Removing tools with an inner thread

1. Hold the tool spindle (3) with the holding bolt (4).
2. Undo the tool tightening screw (2) using the Allen key (1) by turning anti-clockwise. To undo the tool tightening screw (2) turn the Allen key (1) forcefully until the cone comes undone.
3. Now unscrew the tool clockwise by hand from the tool tightening screw (2) and remove from below from the ball of the tool spindle (3).

Tensioning tools with take-up(without inner thread)

1. Undo the tool tightening screw (2) using the Allen key (1) far enough that the take-up is no longer up against that tool tightening screw (2).
2. Press the tool with a forceful push into the tool spindle (3).

Removing tools with take-up(without inner thread)

1. Insert the holding bolt (4) in the tool spindle (3) and hold with one hand.
2. Rotate the Allen key (1) clockwise, this releases the tool which will fall out of the tool spindle (3). In order to prevent damages, place something under the tool to catch it gently.

8. Swiveling the milling head

In order to create bored holes or contact areas under an angle that deviates from the usual vertical position of the milling head, the milling head may be swiveled up to 90 degrees to the left or right.

To swivel the milling head, proceed as follows:

1. Undo the hexagonal nut (6) clockwise against the tool spindle housing far enough that the index bolt (4) can be removed by hand.
2. Slightly undo the hexagonal screw (19) and the hexagonal (21) on the vertical slide by rotating anti-clockwise.
3. Swivel the milling head to the left or right to the desired degree position
4. To secure the milling head in the desired position, tighten the hexagonal screw (19) and hexagonal nut (21)

Bringing the milling head back to the normal position

1. Undo the hexagonal screw (19) and the hexagonal nut (21) on the vertical slide in such a way that the milling head can be swiveled.
2. Bring the milling head back to the vertical position
3. After returning the hexagonal nut (6) back into place on the index bolt, this may be pushed into the opening on the tool spindle housing by hand and secured with light hammer blows.
4. Tighten the hexagonal nut (6) and the securing nut (7) of the index bolt (4) as well as the hexagonal screw (19) and the hexagonal nut (21) on the vertical slide.

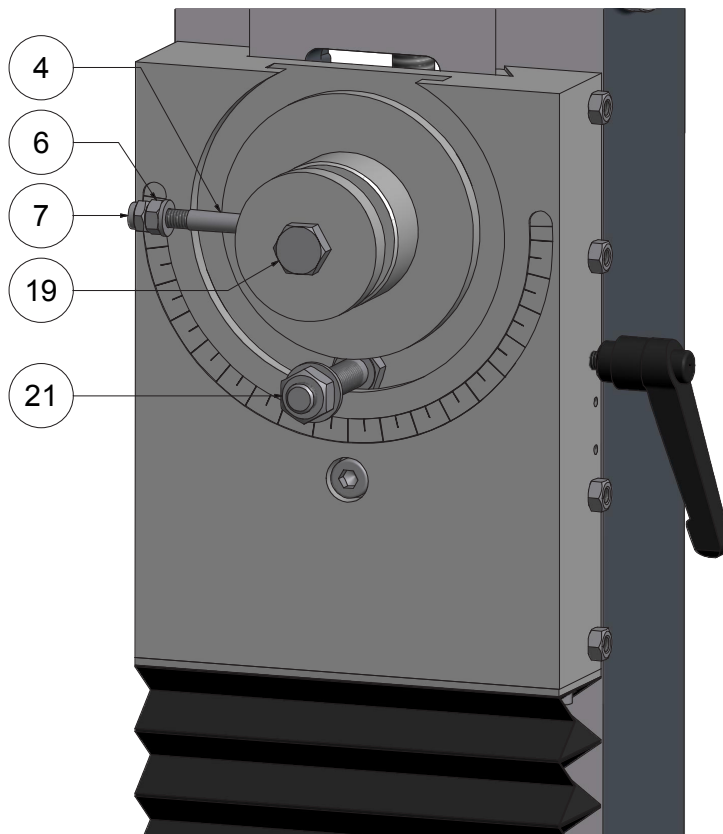

9. Drill stroke - depth stop

It is possible to set the forward feed of the milling machine spindle to a defined dimension.

1. Set the required depth with the activation lever (4).
2. Read the depth off at the scale ring (3).
3. Rotate the depth stop (2) to the correct position so that it touches the milling head.
4. Then tighten the hexagonal screw (1) securely.

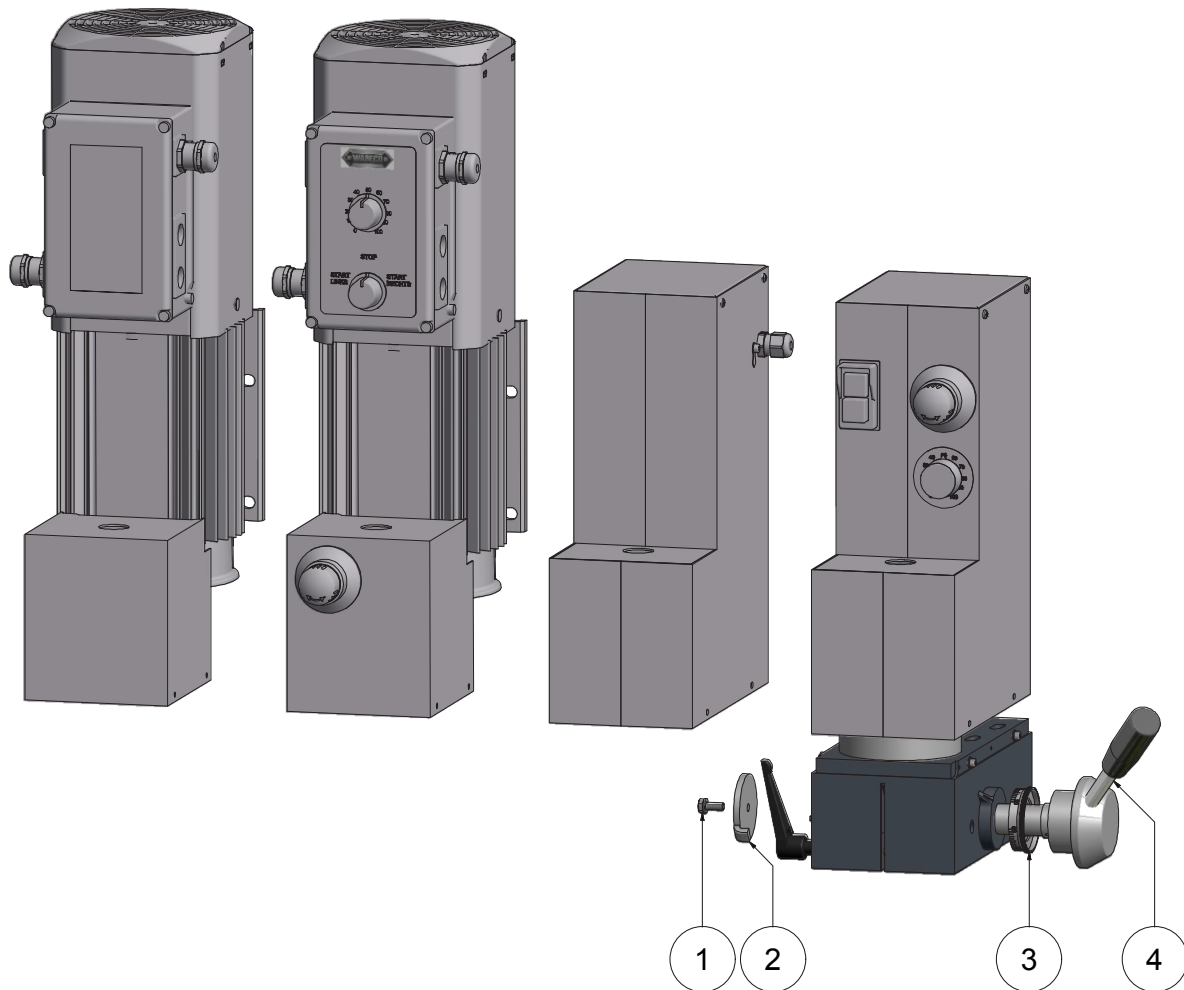

10. Feed motions of the X-, Y- and Z-axes

- The longitudinal motion of the cross slide support (X-axis) is carried out by turning the hand wheel (12). The skid is secured with the clamping lever (3).
- The transverse motion of the cross slide support (Y-axis) is carried out by turning the hand wheel (4). The skid is secured with the clamping lever (21).
- The feed motion of the boring and milling depth (Z-axis) is carried out via the hand wheel (20). To move the milling head using the hand wheel, undo the clamping lever (18) and then clamp again when you have finished.

There are scale rings fitted to enable you to read off the distances.

One interval on the scale represents a distance of 0.05 mm. One full turn of the hand wheel is the same as a skid distance

- Scale ring **X-axis** (15)
with trapezoidal threaded spindle of 4 mm - with ball screw of 5 mm
- Scale ring **Y-axis** (5)
with trapezoidal threaded spindle of 4 mm - with ball screw of 5 mm
- Scale ring **Z-axis** (33)
with trapezoidal threaded spindle of 2 mm - with ball screw of 2.5 mm

Another option for moving the tool spindle is to use the rotation motion of the activation lever (28)

- After undoing the clamping lever (39), the rotation motion may be executed.
- One mark on the scale ring (31) represents a distance of 1 mm.
- Then tighten the clamping lever (39) back up again.
- The largest distance of the tool spindle is 55 mm.

It is recommended not to select a travel distance that is too big, instead, in the event of a greater depth, you should use multiple passes to achieve the milling machine depth needed.

10. Feed motions of the X-, Y- and Z-axes

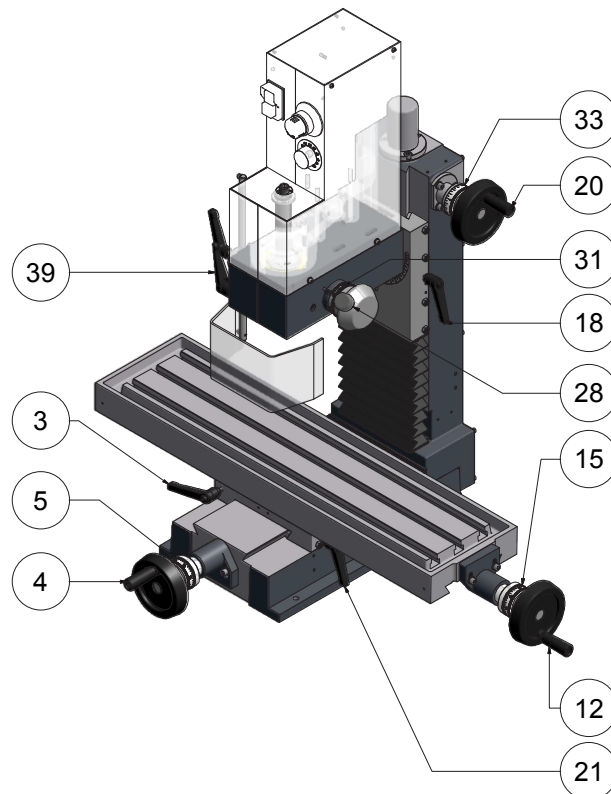

Figure
 F1200 – F1200 hs – F1210 – F1210 hs

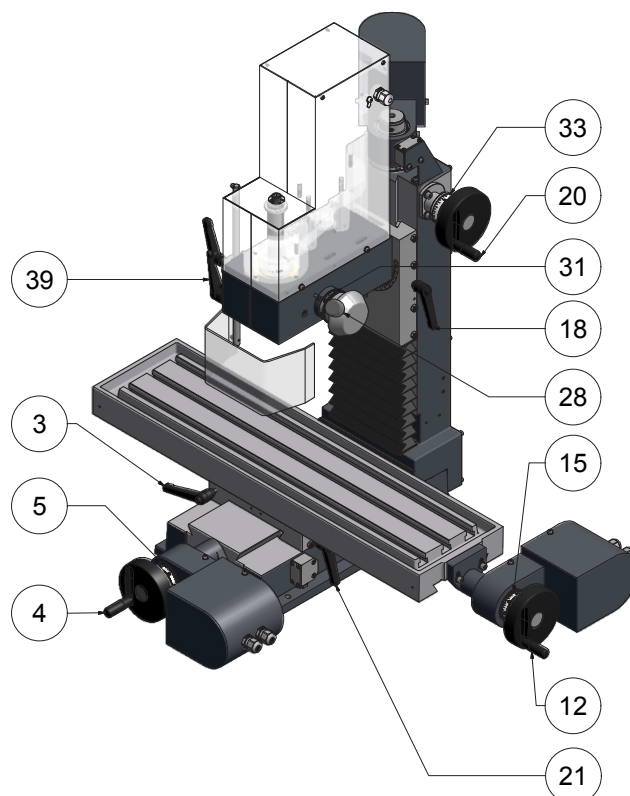

Figure
 F1200-C – F1200-C hs – F1210-C – F1210-C hs
 CC-F1200 – CC-F1200 hs – CC-F1210 – CC-F1210 hs

11. Adjustment of the spindle nuts with trapezoidal thread spindle

The spindle nuts of the milling machines are designed to be adjusted.

If a spindle nut of one of the three axis shows play, proceed as follows.

With spindle nuts with a ball screw, adjustment is neither required nor possible.

11.1 X- and Y-axes

1. To adjust the **spindle nut in the X-axis** (2) the cross slide support is moved to the middle.
2. After undoing the threaded pin (1), the adjustment nut (3) is rotated slightly in a clockwise direction. This rotation causes both nuts to tension each other and removes the play from the operation of the trapezoidal thread spindle.
3. After the setting has been made, tighten the threaded pin (1) back up again.
4. To **adjust the spindle nut of the Y-axis** (5), either unscrew the bellows (7) on the upper skid or carefully tip the machine backwards to gain access to work from the bottom.
5. After undoing the threaded pin (4), the adjustment nut (6) is rotated slightly in a clockwise direction. This rotation causes both nuts to tension each other and removes the play from the operation of the trapezoidal thread spindle.
6. After the setting has been made, tighten the threaded pin (4) back up again.

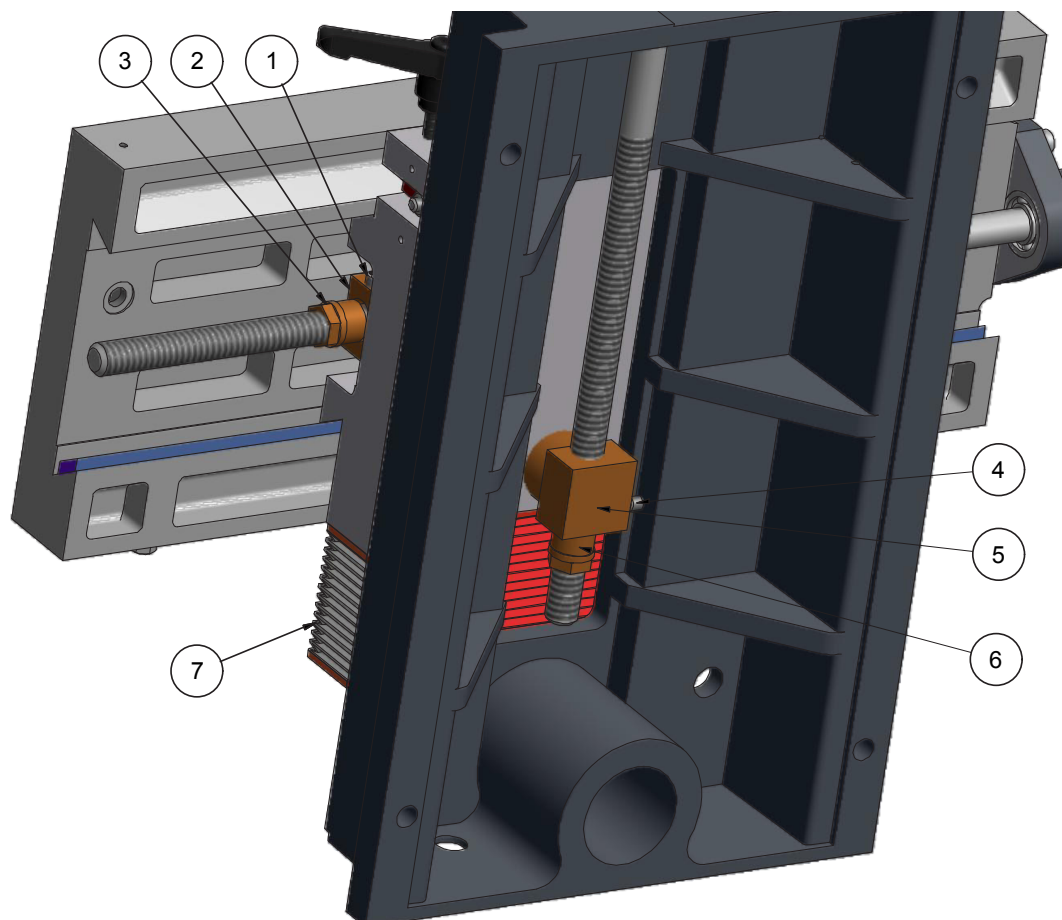

11. Adjustment of the spindle nuts with trapezoidal thread spindle

11.2 Z-axis

1. To adjust the spindle nut in the Z-axis (3), unscrew the cover plate (4).
2. After undoing the threaded pin (2), the adjustment nut (1) is rotated slightly in a clockwise direction. This rotation causes both nuts to tension each other and removes the play from the operation of the trapezoidal thread spindle.
3. After the setting has been made, tighten the threaded pin (2) back up again.

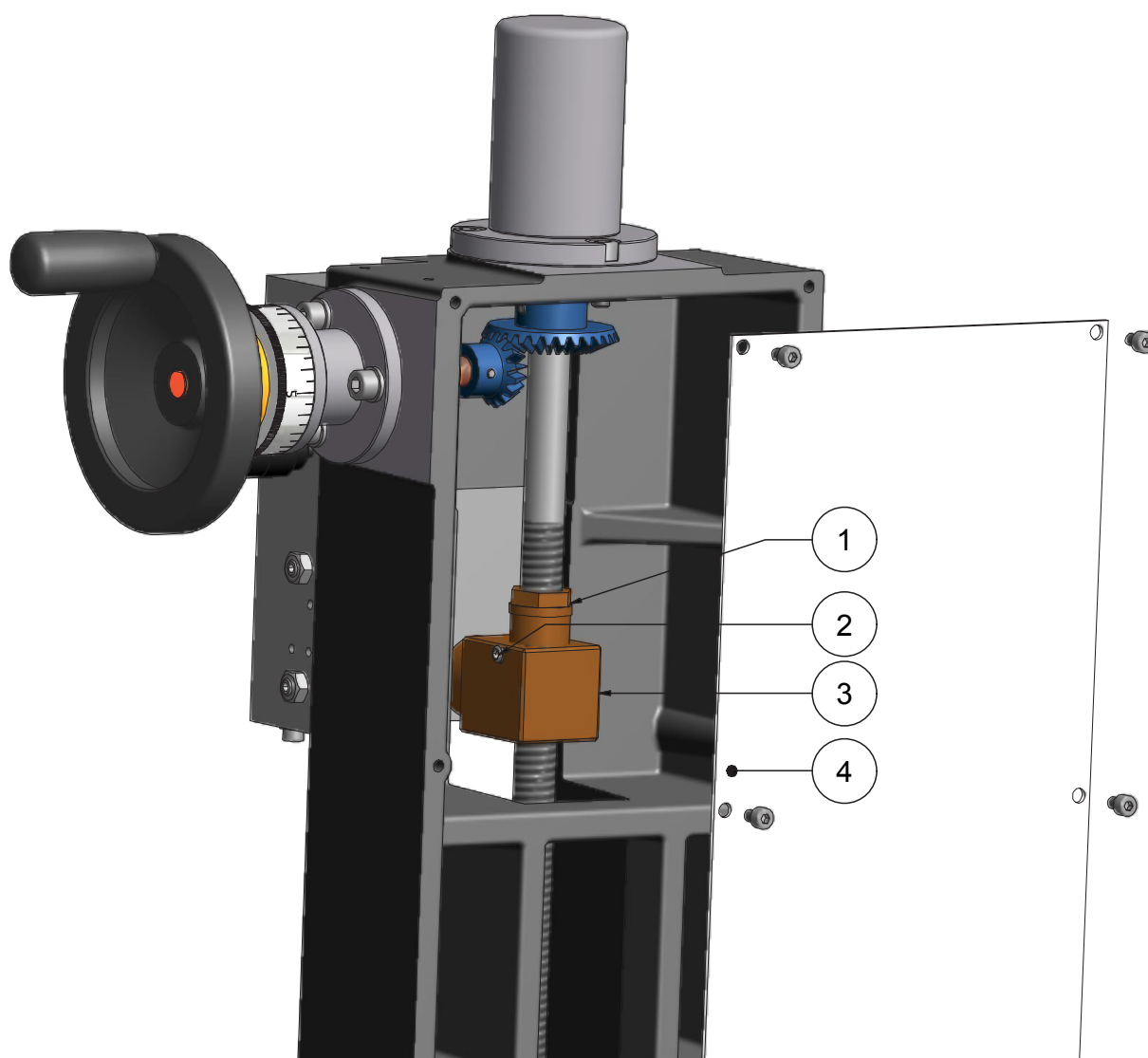

12. Adjustment of the dovetail guides

In order to achieve optimum results when adjusting the dovetail guides, the relevant dovetail guides should be cleaned and lubricated before you start (see „Lubricating the machine“)

Further all tensioning devices and loose parts should be removed from the machine table.

Pay attention to ensure that the clamping lever of the dovetail guide you wish to adjust is open

To adjust the dovetail guides, proceed as follows:

1. Undo the lock nuts (1)
2. Set the adjustment bar of the relevant axis and all the associated threaded pins (2) in such a way that the relevant axis has no play and can be moved with little force. To do this, the appropriate skid should be moved during the setting process and checked for play and appropriate ease of movement.
3. When the threaded pins (2) are set correctly, tighten the lock nuts (1) back up again

Only set the threaded pins (2) if they are in the range of the counter guide! To do this, the skid may need to be moved into this area. Otherwise the dovetail guide may jam and this may cause damages.

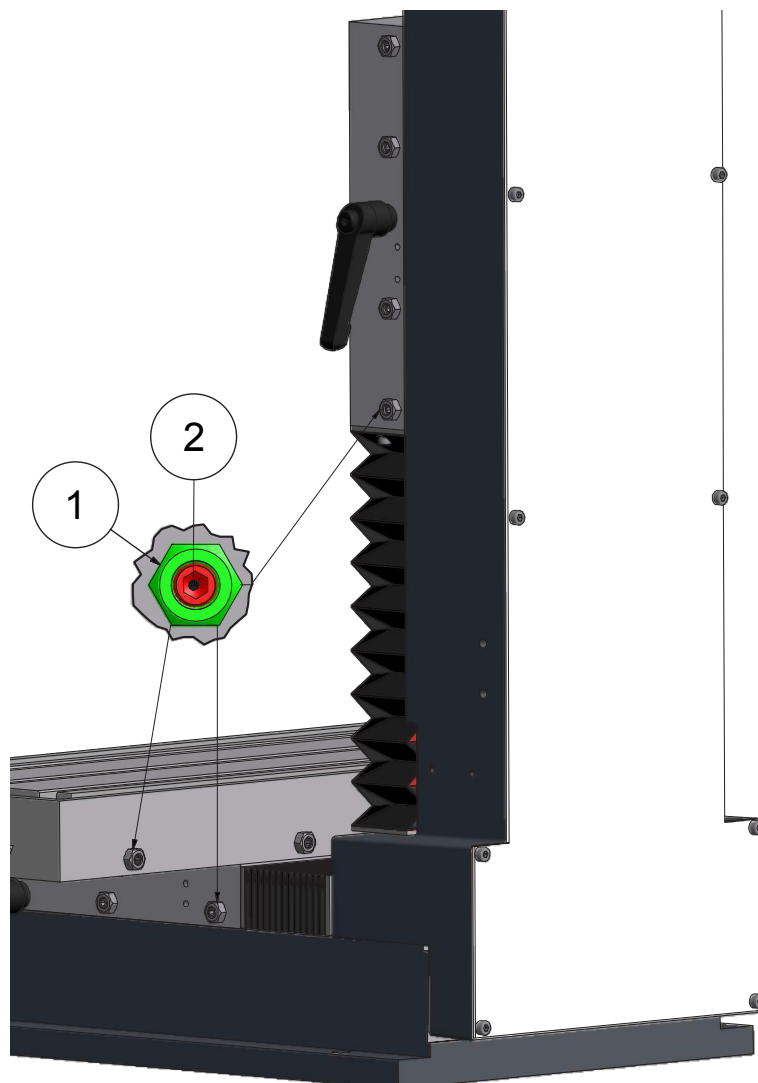

13. Maintenance

A long lifetime of the machine will depend on the appropriate care and maintenance.

- **All maintenance and repair tasks may only be carried out with the grounded plug pulled.**
- The machine must be cleaned after each use.
- If the machine is set up in a wet room, all exposed parts must be oiled after each use to prevent corrosion.
- Always lubricate all moving parts well.
- In the event of bearing or skid play, immediately adjust in order to prevent it from destroying the bearing or skid guide

Approximately every 100 operating hours

- clean the carbon brushes and collector of the drive motor (1.4 kW) with a piece of coarse sandpaper. Remove approximately 0.1 mm from the carbon brushes, then smooth out the contact surface with fine sandpaper.
- check the tension of the gear belt and adjust if necessary.
- check the play in the guides and feed spindles and set if necessary.

14. Lubrication of the machine

The lubrication process:

- reduces wear and friction
- increases the lifetime
- protects metal surfaces from corrosion

We recommend:

- A class 2NLGI multi-purpose grease for lubrication.
- A lubrication oil with a viscosity of 100 mm²/s for oiling.

The machine is to be lubricated every 8 hours of operation in accordance with the lubrication plan. The lubrication points

- Dovetail guide, base plate
- Dovetail guide, upper skid
- Dovetail guide, Z-column
- Trapezoidal thread spindles
- Sleeve and feed pinion (for sleeve stroke)

are lubricated with the help of an oil can and an ordinary lubrication oil by moving the skid or sleeve backwards and forwards.

All other lubrication points are lubricated with a grease press or a brush using multi-purpose grease.

14. Lubrication of the machine

1

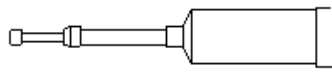

every 8 hours of operation

2

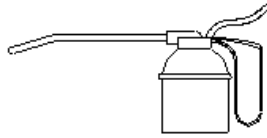

every 8 hours of operation

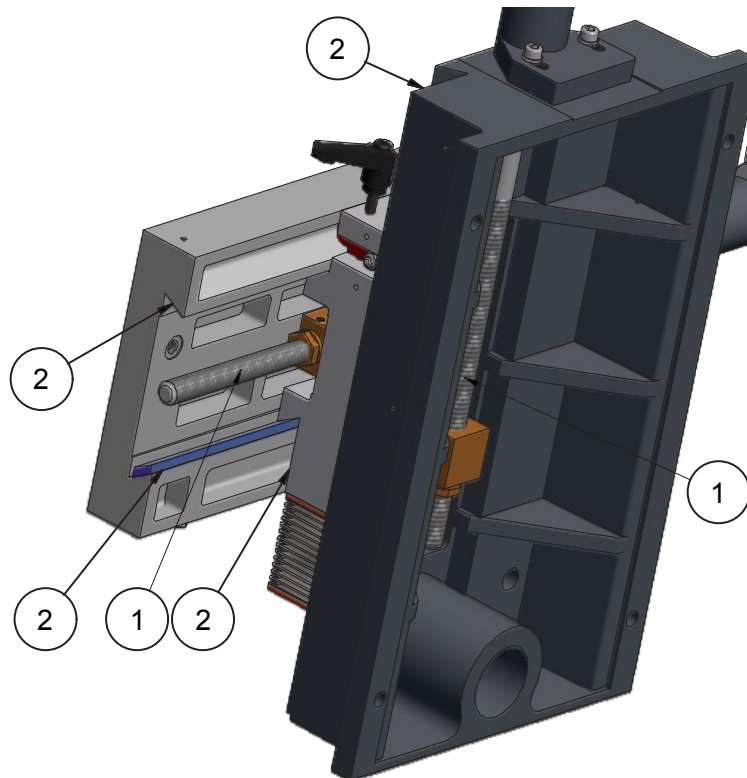
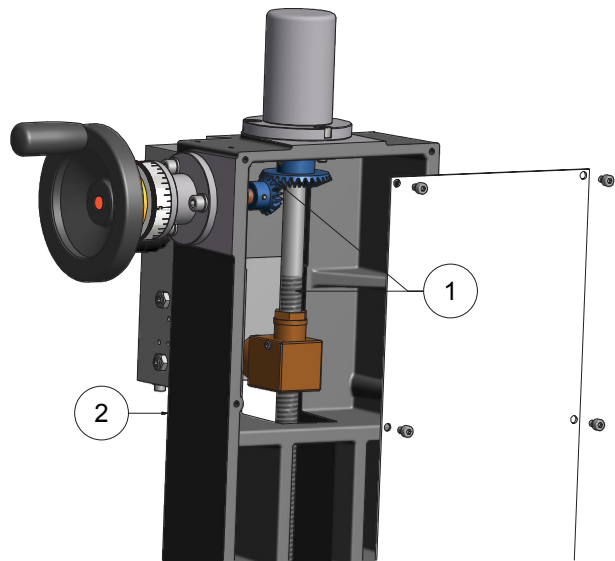
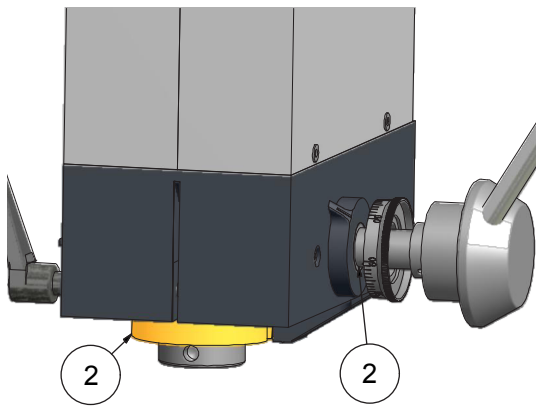

The **borer spindle** and **spindle bearing** do not need to be lubricated since the ball bearings have a closed construction form and the bearings have been supplied at the factory with sufficient grease for the lifetime of the machine.

15. Operational faults and the elimination of such

Operational faults	Possible cause	Remedy
Machine cannot be switched on	230V voltage is not present	Plug is not fitted correctly
		Check the fuse for the socket
	Emergency off switch not unlocked	Unlock the emergency off switch
	Vibrations (e.g. by transportation) has caused the plugged contacts of the drive motor (1.4 kW) board to come undone	Pull the power plug! Lift the lid with board from the cover hood of the drive motor and check all plugged contacts
Main spindle motor no longer starts after the unlocking of the emergency off switch	Motor controller must be unlocked	For machines with a 1.4 kW drive motor, the motor must be switched on again using the ON/OFF switch after the emergency off switch is unlocked. After unlocking, wait approximately 5 seconds before switching the machine on.
		For machines with a 2.0 kW drive motor, the spindle turn switch must first be set to stop after the emergency off switch is unlocked. In this position, wait approximately 5 seconds before switching the machine on. After this, the motor may be switched on as usual.
The drive motor (1.4 kW) experiences „skips“ during operation	Carbon brushes and collector of the drive motor are contaminated	Clean the carbon brushes and collector of the drive motor with a piece of coarse sandpaper (See „Maintenance“ section
	Carbon brushes are worn	Replace carbon brushes with new ones

15. Operational faults and the elimination of such

Operational faults	Possible cause	Remedy
Axis skid can only be moved with considerable force	Clamping lever of the axis is tightened	Open the clamping lever
	Guide play is set too narrowly	Adapt the guide play
	Play of the trapezoidal-threaded nut is set too narrowly	Adapt the play of the trapezoidal-threaded nut
Sleeve stroke too short	Borer stroke depth stop limits the sleeve stroke	Set the borer stroke depth stop (See „Drill stroke depth stop“)
Rust on workpieces of machine parts when using coolant lubrication	Wrong coolant set	Check the ratio of coolant and correct if necessary (Do not use pure water to cool!)
Tool holder cannot be inserted into the main spindle	Incorrect tool ball in the tool holder	Only use the appropriate tool holders for the machine
	Use tool with take-up	Turn the tool tightening screw back further (See „Fitting and removing the tools“)
	Inner cone of the main spindle or outer cone of the tool holder is contaminated	Clean the relevant cone
Tool overheated	Revolutions too high	Reduce the revolutions
	Feed too high	Reduce the feed
	Working without coolant	Use coolant
	Insufficient coolant feed at the cutting edge	Align the coolant hose correctly

15. Operational faults and the elimination of such

Operational faults	Possible cause	Remedy
Tool overheated	Tool blunt	Sharpen tool or use a new tool
	Increased friction caused by shaving build up in the tensioning groove of the tool	Remove the shavings from the hole more frequently (withdraw
		Use a coated tool
		Wash the processing area with coolant
	Unsuitable tool chosen for the material to be processed	Only use the suitable tool for the relevant material
Tool holder cannot be removed from the main spindle	Tool was not inserted according to instructions (tool screw can be unscrewed upwards	<p>In the event of a remove tool tightening screw, a suitable and sufficiently long threaded rod may be turned through the spindle into the tool holder. A blow on the end of the threaded rod will detach the tool holder from the main spindle. The main spindle must be cushioned when doing this. Otherwise the impact will act on the spindle bearing and may damage it. In order to prevent damages to the tool to be removed, use suitable cushioning.</p> <p>(See „Fitting and removing the tools“)</p>

16. Control elements

16.1 Milling machines F1200 - F1210 (1.4 kW)

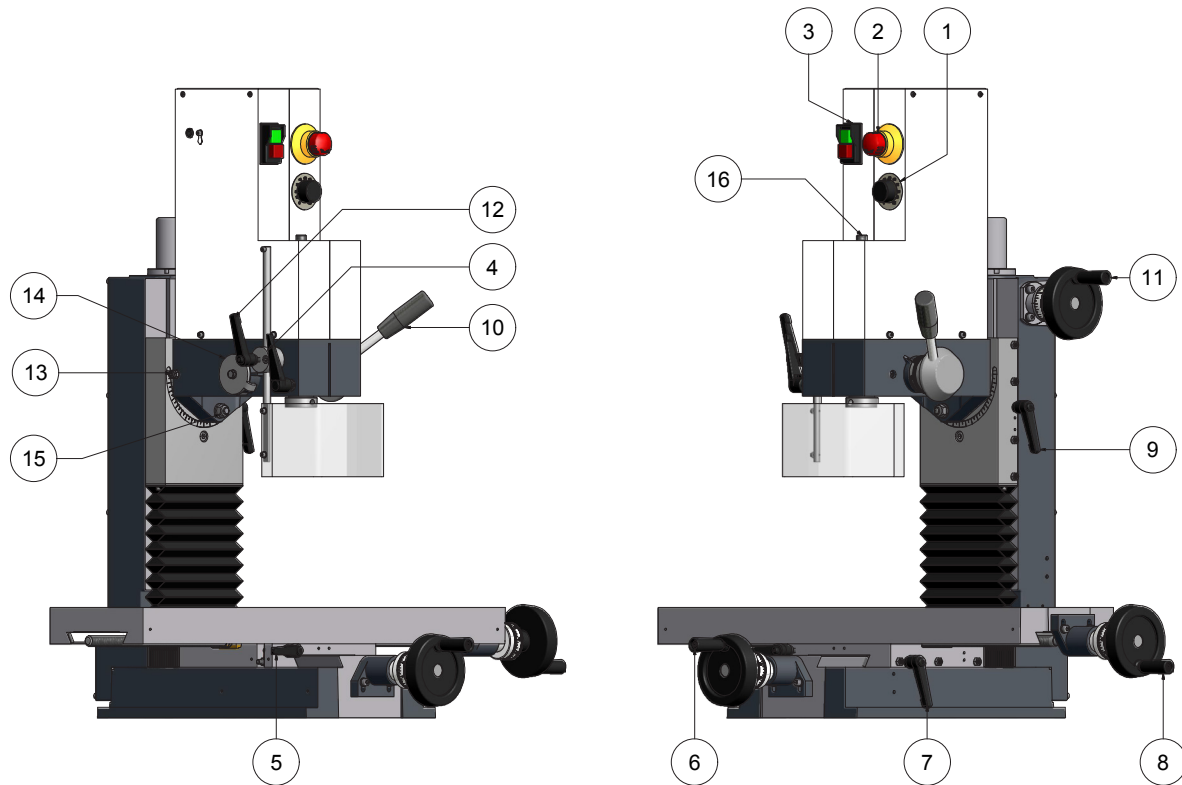

1. Potentiometer rotating knob for speed selection of the electrical drive motor
2. Emergency off switch
3. ON/OFF switch with under-voltage trigger
4. Clamping lever for securing the tool spindle
5. Clamping lever for securing the longitudinal motion (**X-axis**) at the cross slide support
6. Hand wheel for adjusting the transverse motion (**Y-axis**) of the cross slide support
7. Clamping lever for securing the transverse motion (**Y-axis**) at the cross slide support
8. Hand wheel for adjusting the longitudinal motion (**X-axis**) of the cross slide support
9. Clamping lever for securing the boring and milling depth
10. Activation lever for moving the tool spindle (sleeve stroke)
11. Hand wheel for setting the boring and milling depth
12. Clamping lever for securing the protective hood
13. Index bolt for securing the milling head
14. Depth stop for boring
15. Hexagonal nut for swiveling the milling head
16. Tool tightening screw

16. Control elements

16.2 Milling machines F1200 hs - F1210 hs (2.0 kW)

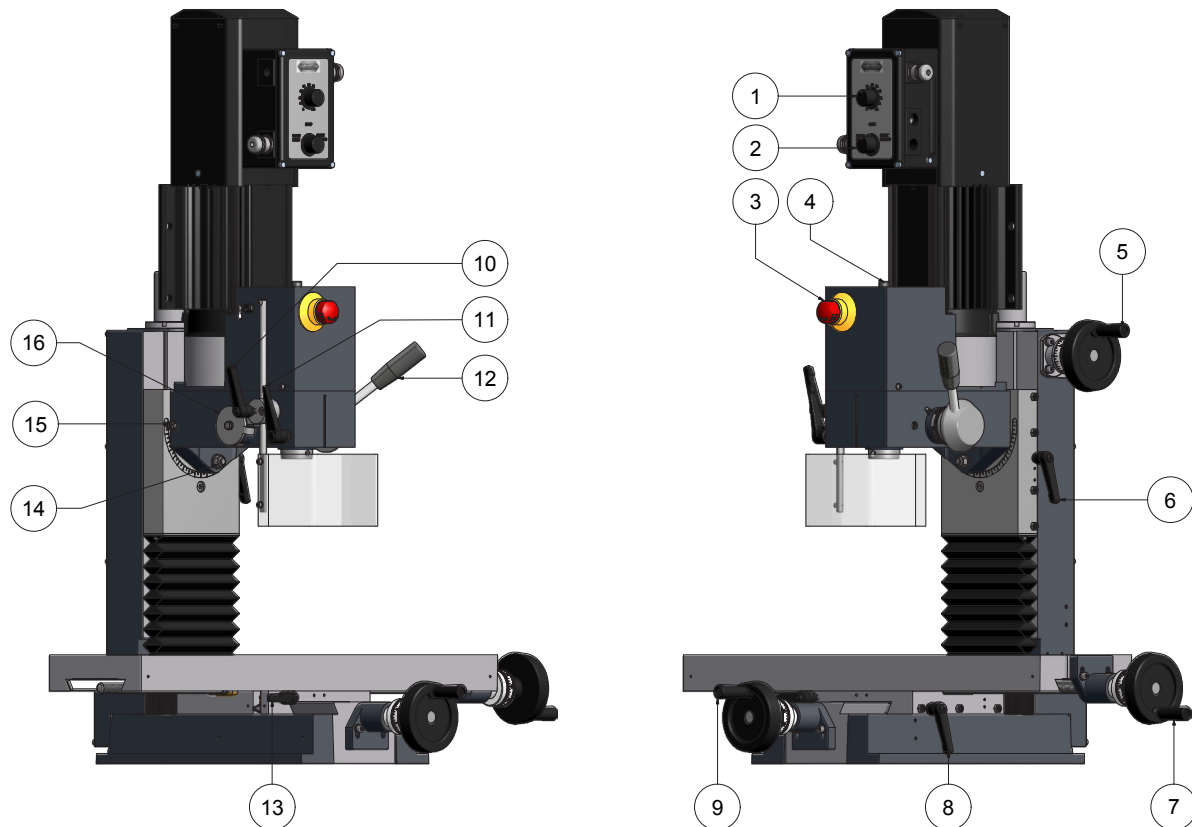

1. Potentiometer rotating knob for speed selection of the electrical drive motor
2. 3-setting switch of the electrical drive motor (START RIGHT - STOP - START LEFT)
3. Emergency off switch
4. Tool tightening screw
5. Hand wheel for setting the boring and milling depth
6. Clamping lever for securing the boring and milling depth
7. Hand wheel for adjusting the longitudinal motion (**X-axis**) of the cross slide support
8. Clamping lever for securing the transverse motion (**Y-axis**) at the cross slide support
9. Hand wheel for adjusting the transverse motion (**Y-axis**) of the cross slide support
10. Clamping lever for securing the protective hood
11. Clamping lever for securing the tool spindle
12. Activation lever for moving the tool spindle (sleeve stroke)
13. Clamping lever for securing the longitudinal motion (**X-axis**) at the cross slide support
14. Hexagonal nut for swiveling the milling head
15. Index bolt for securing the milling head
16. Depth stop for boring

16. Control elements

16.3 Milling machines F1200-C – F1210-C (1.4 kW)

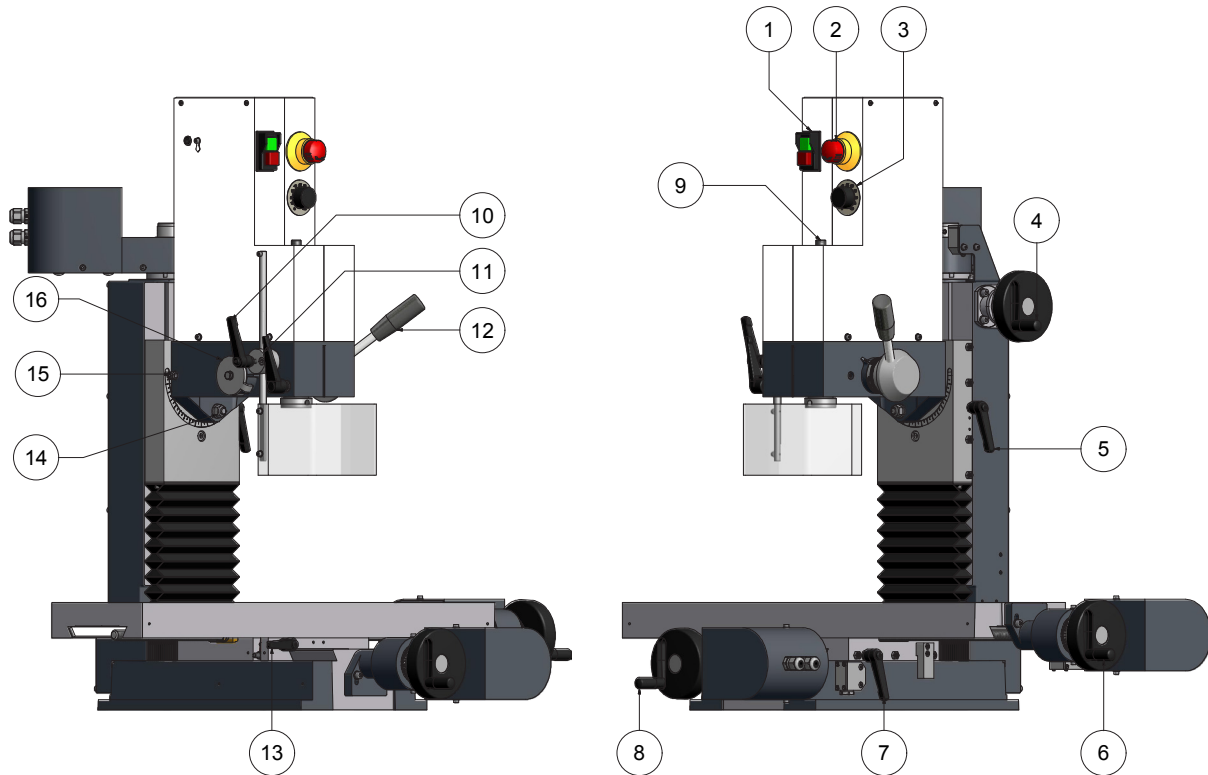

1. ON/OFF switch with under-voltage trigger
2. Emergency off switch
3. Potentiometer rotating knob for speed selection of the electrical drive motor
4. Hand wheel for setting the boring and milling depth
5. Clamping lever for securing the boring and milling depth
6. Hand wheel for adjusting the longitudinal motion (**X-axis**) of the cross slide support
7. Clamping lever for securing the transverse motion (**Y-axis**) at the cross slide support
8. Hand wheel for adjusting the transverse motion (**Y-axis**) of the cross slide support
9. Tool tightening screw
10. Clamping lever for securing the protective hood
11. Clamping lever for securing the tool spindle
12. Activation lever for moving the tool spindle (sleeve stroke)
13. Clamping lever for securing the longitudinal motion (**X-axis**) at the cross slide support
14. Hexagonal nut for swiveling the milling head
15. Index bolt for securing the milling head
16. Depth stop for boring

16. Control elements

16.4 Milling machines F1200-C hs – F1210-C hs (2.0 kW)

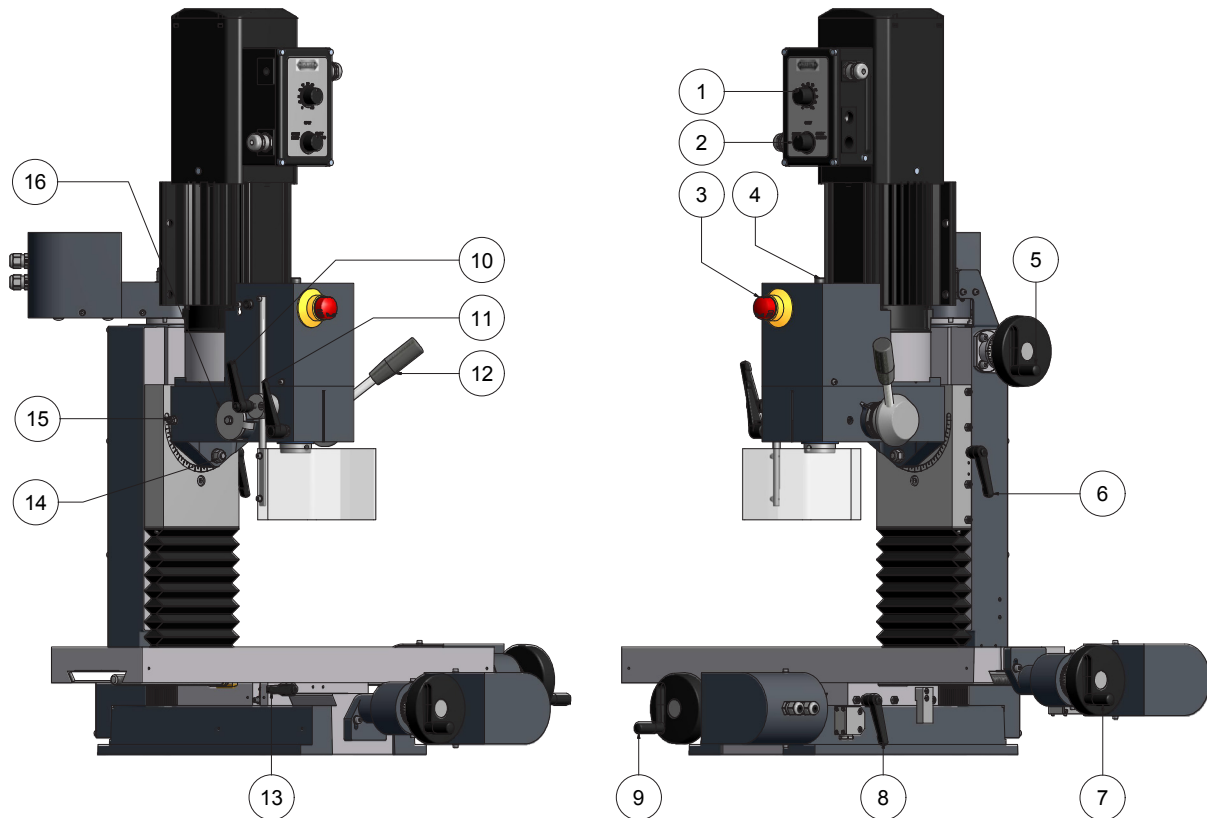

1. Potentiometer rotating knob for speed selection of the electrical drive motor
2. 3-setting switch of the electrical drive motor (START RIGHT - STOP - START LEFT)
3. Emergency off switch
4. Tool tightening screw
5. Hand wheel for setting the boring and milling depth
6. Clamping lever for securing the boring and milling depth
7. Hand wheel for adjusting the longitudinal motion (**X-axis**) of the cross slide support
8. Clamping lever for securing the transverse motion (**Y-axis**) at the cross slide support
9. Hand wheel for adjusting the transverse motion (**Y-axis**) of the cross slide support
10. Clamping lever for securing the protective hood
11. Clamping lever for securing the tool spindle
12. Activation lever for moving the tool spindle (sleeve stroke)
13. Clamping lever for securing the longitudinal motion (**X-axis**) at the cross slide support
14. Hexagonal nut for swiveling the milling head
15. Index bolt for securing the milling head
16. Depth stop for boring

16. Control elements

16.5 CNC milling machines CC-F1200 – CC-F1210 (1.4 kW)

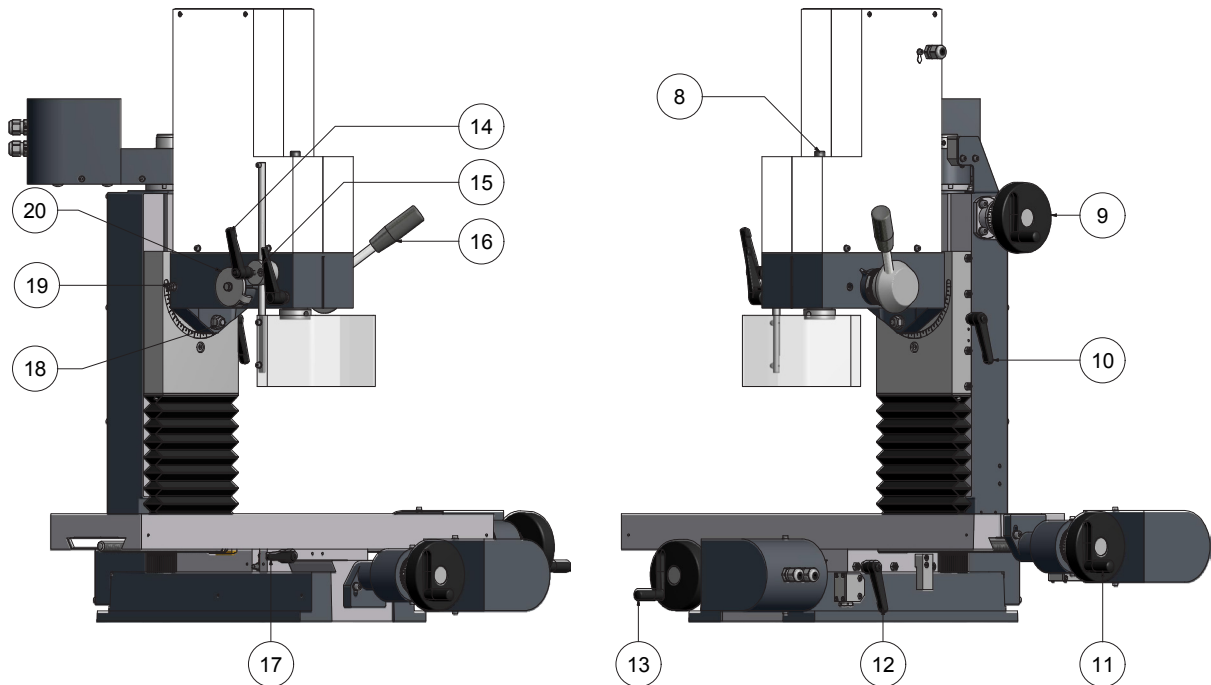

- 8. Tool tightening screw
- 9. Hand wheel for setting the boring and milling depth
- 10. Clamping lever for securing the boring and milling depth
- 11. Hand wheel for adjusting the longitudinal motion (**X-axis**) of the cross slide support
- 12. Clamping lever for securing the transverse motion (**Y-axis**) at the cross slide support
- 13. Hand wheel for adjusting the transverse motion (**Y-axis**) of the cross slide support
- 14. Clamping lever for securing the protective hood
- 15. Clamping lever for securing the tool spindle
- 16. Activation lever for moving the tool spindle (sleeve stroke)
- 17. Clamping lever for securing the longitudinal motion (**X-axis**) at the cross slide support
- 18. Hexagonal nut for swiveling the milling head
- 19. Index bolt for securing the milling head
- 20. Depth stop for boring

16. Control elements

16.5 CNC milling machines CC-F1200 – CC-F1210 (1.4 kW)

16.5.1 Switch cover on CNC machine control panel

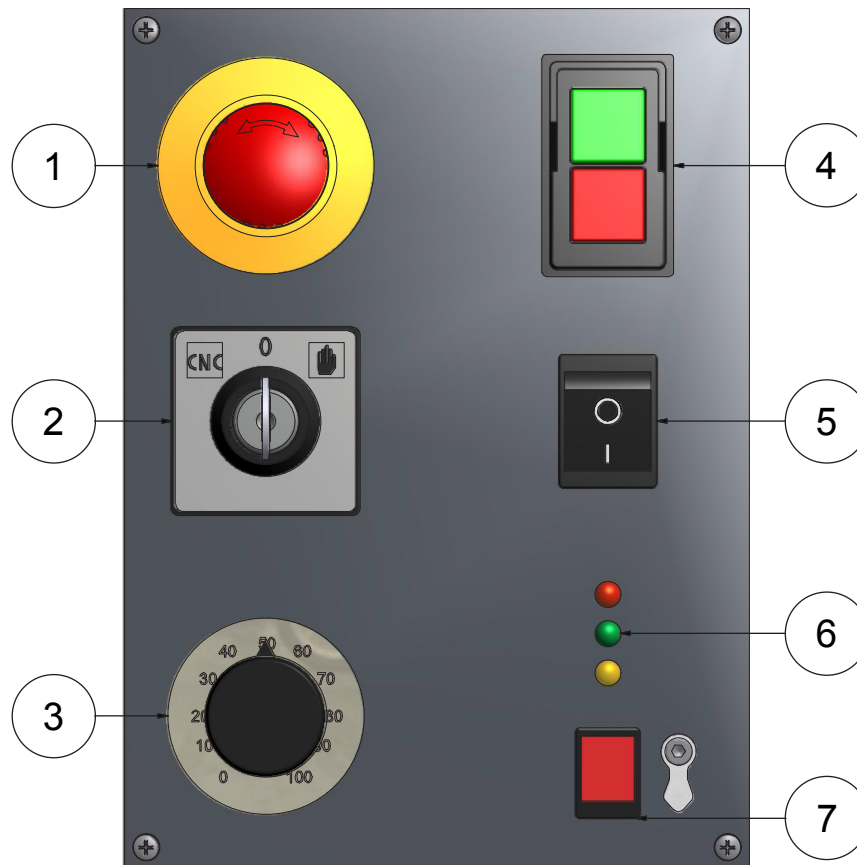

1. Emergency off switch
2. Mode selection switch (CNC operation) (Idle position) (Set-up mode)
3. Potentiometer rotating knob for speed selection of the electrical drive motor
4. ON/OFF switch with under-voltage trigger
5. Coolant ON/OFF (if coolant pump is connected)
6. Diodes to display the status of the controller
7. Reset switch for controller

16. Control elements

16.6 CNC milling machines CC-F1200 hs – CC-F1210 hs (2.0 kW)

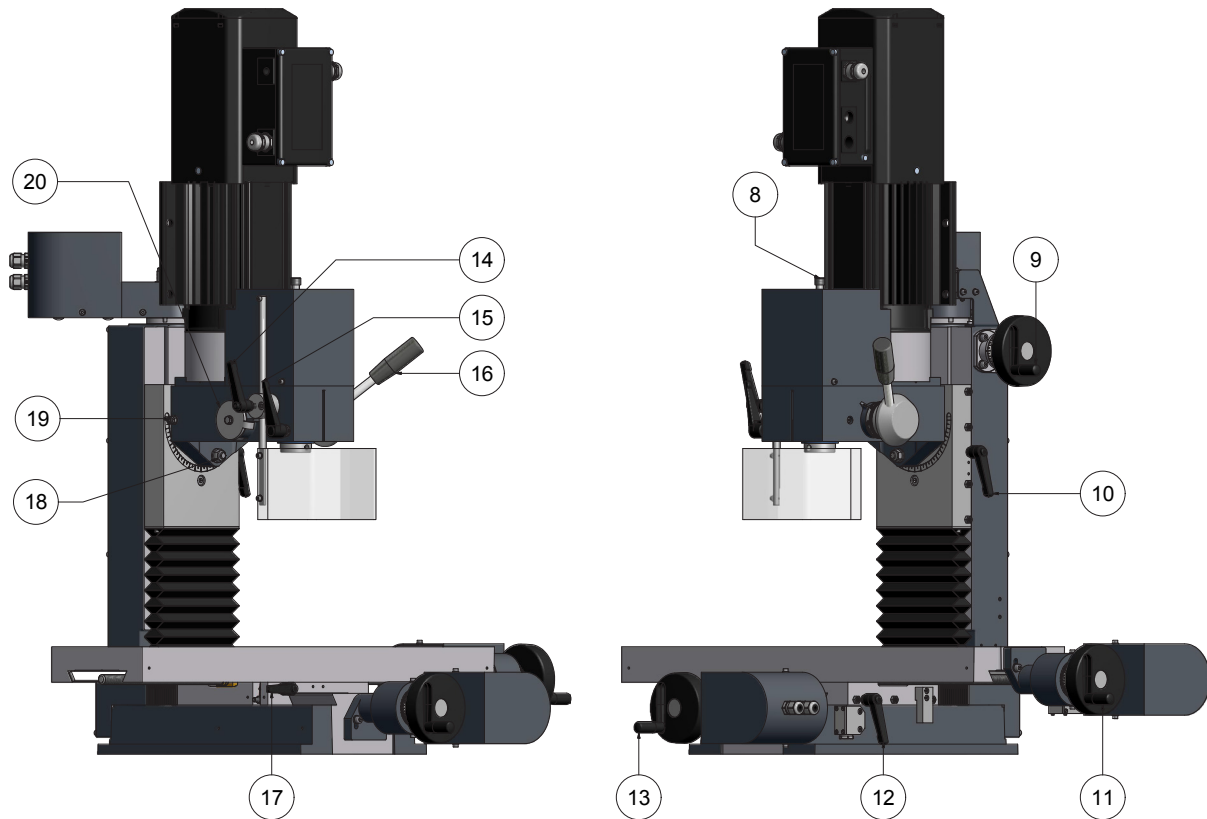

- 8. Tool tightening screw
- 9. Hand wheel for setting the boring and milling depth
- 10. Clamping lever for securing the boring and milling depth
- 11. Hand wheel for adjusting the longitudinal motion (**X-axis**) of the cross slide support
- 12. Clamping lever for securing the transverse motion (**Y-axis**) at the cross slide support
- 13. Hand wheel for adjusting the transverse motion (**Y-axis**) of the cross slide support
- 14. Clamping lever for securing the protective hood
- 15. Clamping lever for securing the tool spindle
- 16. Activation lever for moving the tool spindle (sleeve stroke)
- 17. Clamping lever for securing the longitudinal motion (**X-axis**) at the cross slide support
- 18. Hexagonal nut for swiveling the milling head
- 19. Index bolt for securing the milling head
- 20. Depth stop for boring

16. Control elements

16.6 CNC milling machines CC-F1200 hs – CC-F1210 hs (2.0 kW)

16.6.1 Switch cover on CNC operating console

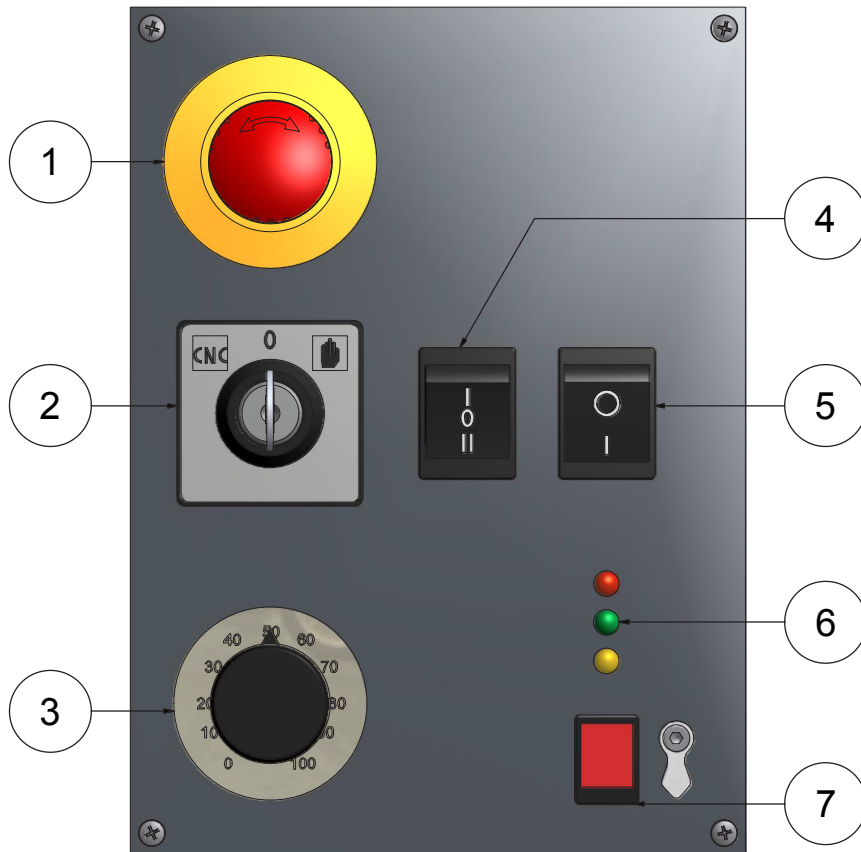

1. Emergency off switch
2. Mode selection switch (CNC operation) (Idle position) (Set-up mode)
3. Potentiometer rotating knob for speed selection of the electrical drive motor
4. 3-setting switch of the electrical drive motor (I=START RIGHT 0=STOP II=START LEFT)
5. Coolant ON/OFF (if coolant pump is connected)
6. Diodes to display the status of the controller
7. Reset switch for controller

17. Drawings and legends

17.1 Protective hood

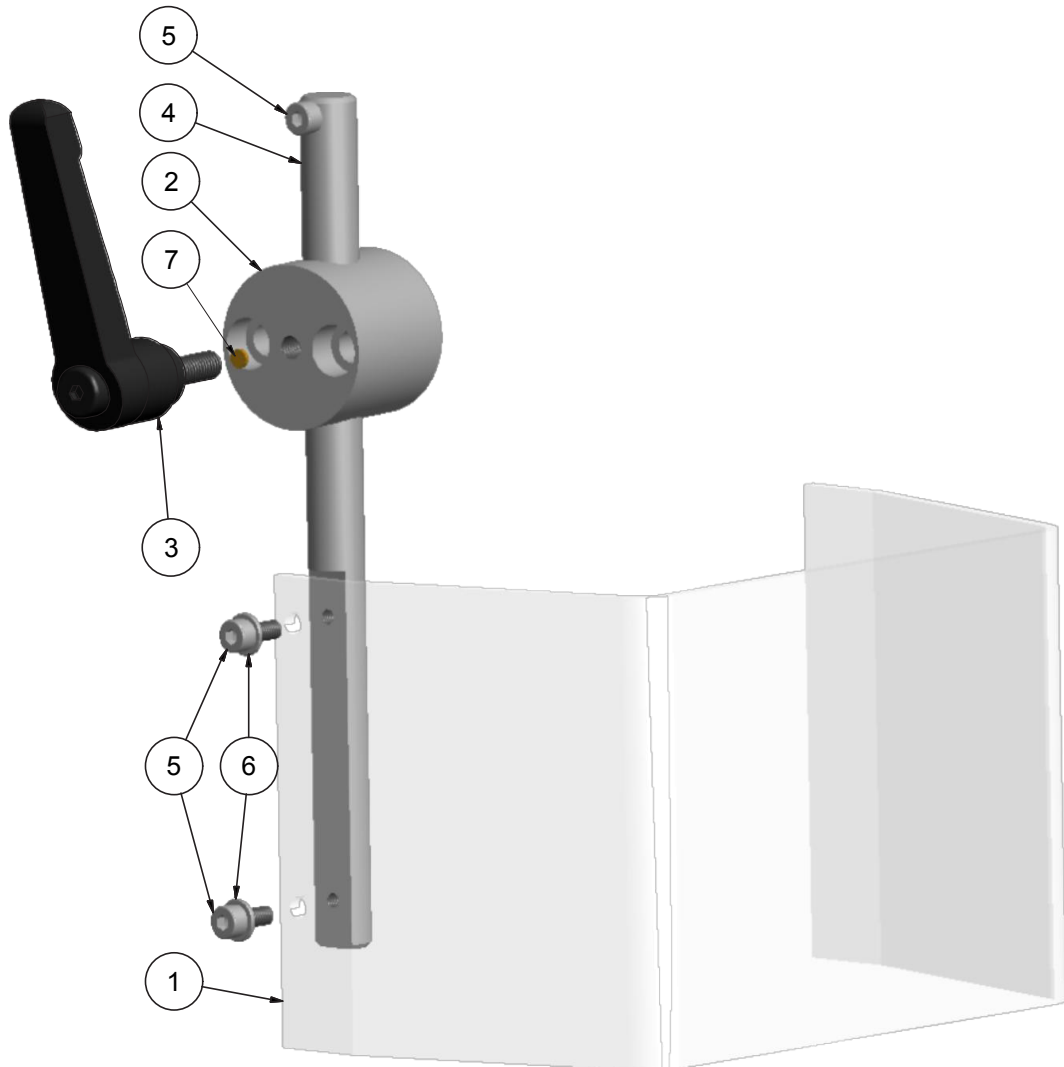

17. Drawings and legends

17.1 Protective hood

Part no.	Items	Order no.	Description
1	1	51400283-0003	Protective hood
2	1	51006535-0002	Clamp holder
3	1	51507029	Tensioning lever
4	1	51004010-0010	Guide rod
5	3	16191200004010	Screw
6	2	16112500004000	Washer
7	1	51007250-0001	Push piece

17. Drawings and legends

17.2 Electronic hood with 1.4 kW motor

17.2.1 F1200 – F1210 - F1200-C – F1210-C

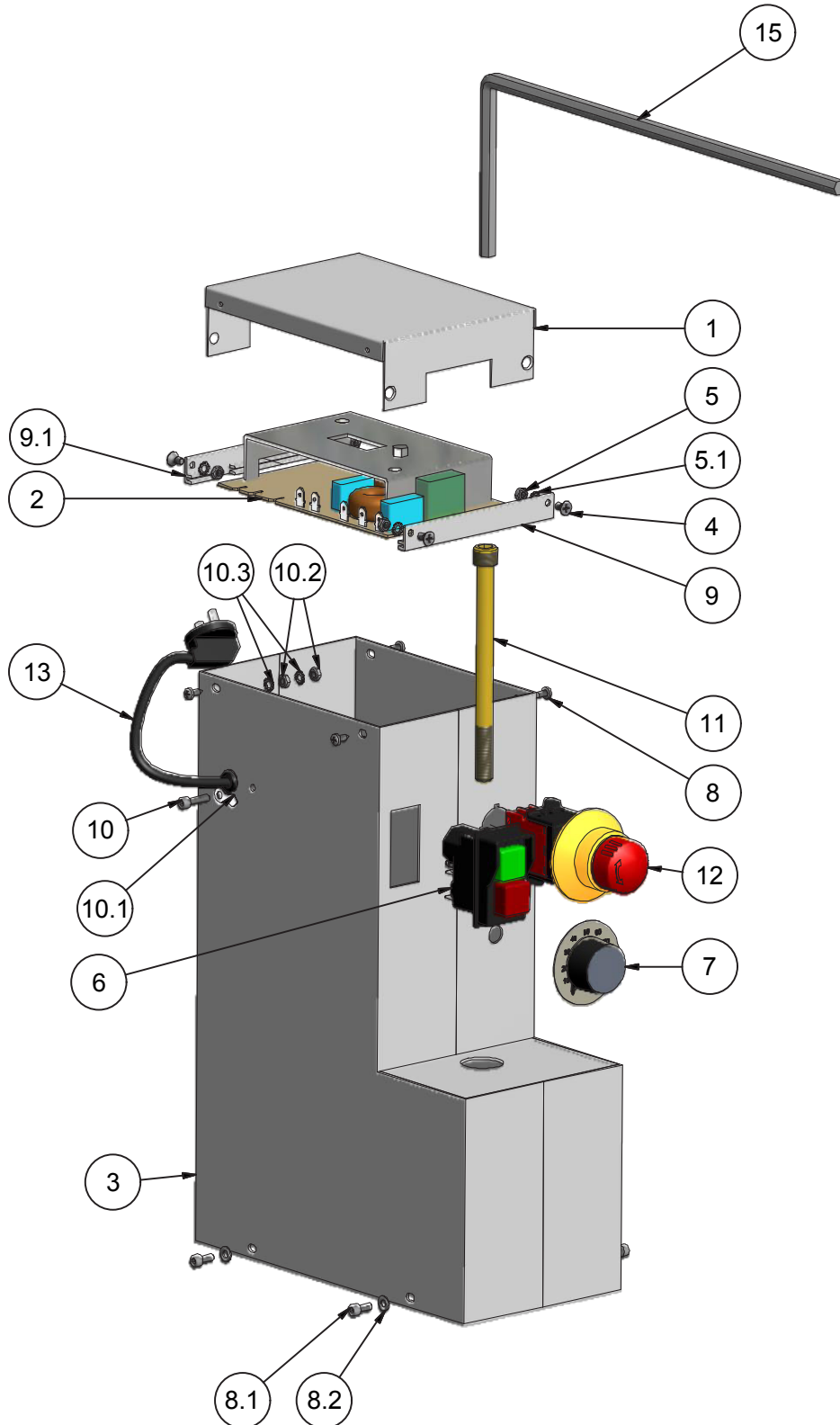

17. Drawings and legends

17.2 Electronic hood with 1.4 kW motor

17.2.1 F1200 – F1210 - F1200-C – F1210-C

Part no.	Items	Order no.	Description
1	1	51401212-00011	Cover
2	1	51501402	Board
3	1	51401211-0001	Cover hood
4	4	16196500004008	Screw
5	4	16193400004000	Nut
5.1	4	16167980004000	Fanned washer
6	1	51500606-0001	On-Off switch
7	1	51500807-0002	Potentiometer with cable and connector
7.1	1	51500807-00021	Potentiometer. complete
8	4	16179810003095	Screw
8.1	4	16191200004010	Screw
8.2	4	16112500004000	Washer
9	1	51500401-0002	Board holder without cut-out
9.1	1	51500401-0003	Board holder with cut-out
10	1	16191200004020	Screw
10.1	1	51501304	Symbol for earthed connection
10.2	2	16193400004000	Nut
10.3	2	16167980004000	Fanned washer
11			Tool tightening screw
11	1	91200010130-01	MT2 with tightening thread M10
	1	91200012160-01	MT3 or ISO30 with tightening thread M12
12	1	51500624-0001	Emergency off switch, complete
13	1	51500920-0002	Mains cable with strain relief
15			Allen key
15	1	51007430-0001	8 mm for tool tightening screw MT2
	1	51007440-0001	10 mm for tool tightening screw MT3 or ISO30

17. Drawings and legends

17.2 Electronic hood with 1.4 kW motor

17.2.2 CC-F1200 – CC-F1210

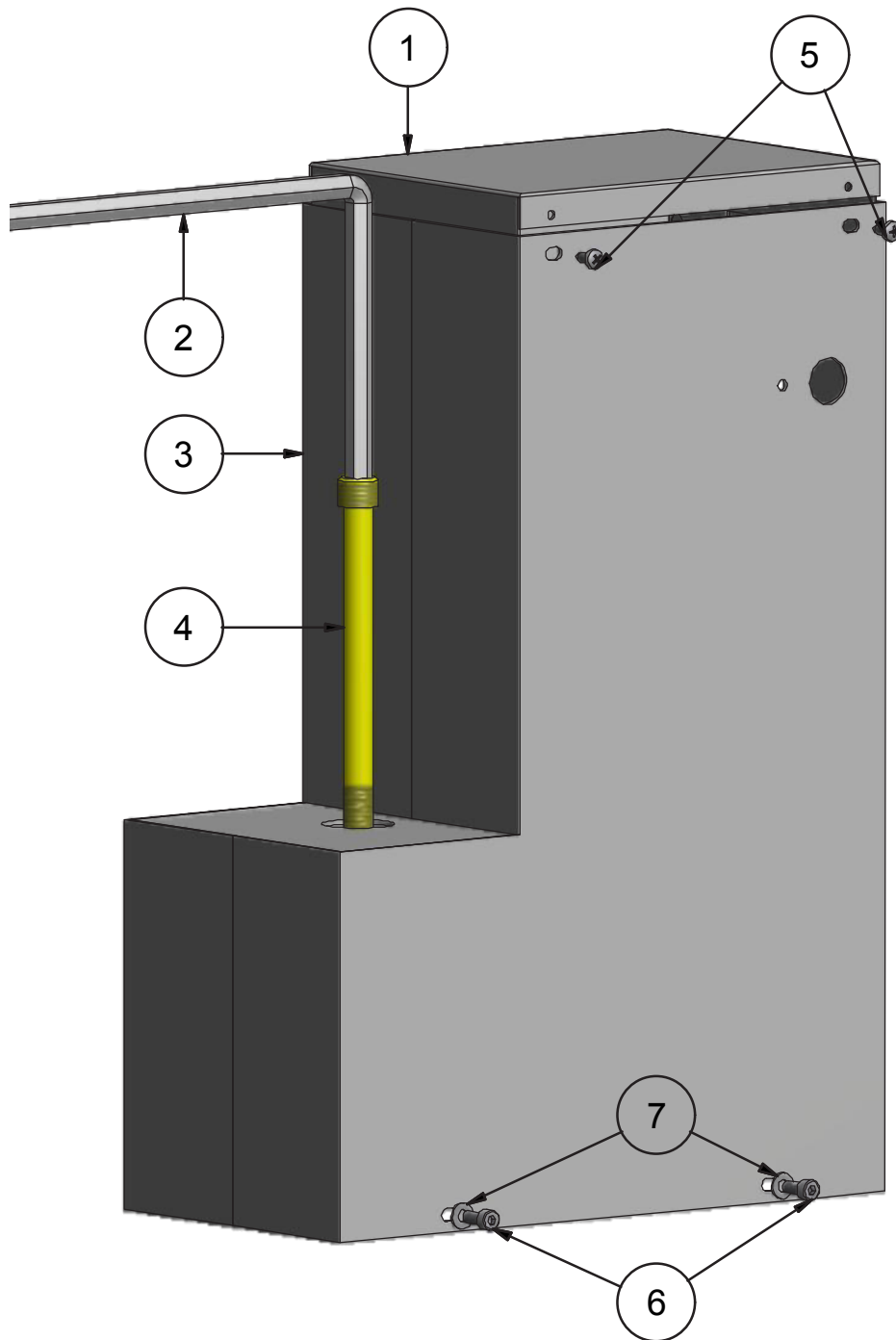

17. Drawings and legends

17.2 Electronic hood with 1.4 kW motor

17.2.2 CC-F1200 – CC-F1210

Part no.	Items	Order no.	Description
1	1	51401212-0001	Cover
2			Allen key
2	1	51007430-0001	8 mm for tool tightening screw
	1	51007440-0001	10 mm for tool tightening screw MT3 or ISO30
3	1	51401504-0001	Cover hood
4			Tool tightening screw
4	1	91200010130-01	MT2 with tightening thread M10
	1	91200012160-01	MT3 or ISO30 with tightening thread M12
5	4	16179810003095	Screw
6	4	16191200004010	Screw
7	4	16112500004000	Washer

17. Drawings and legends

17.3 Milling head with 1.4 kW motor

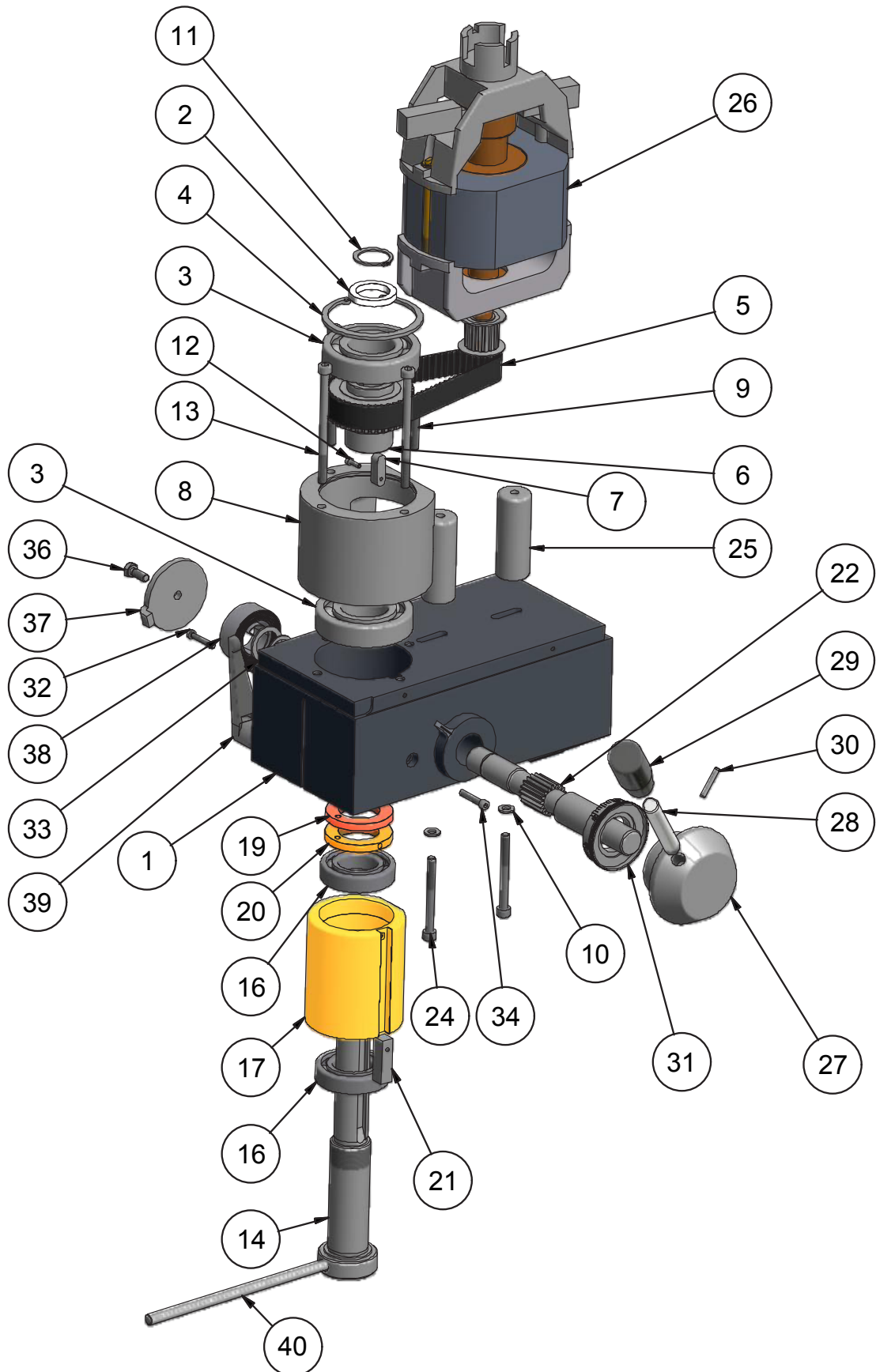

17. Drawings and legends

17.3 Milling head with 1.4 kW motor

Part no.	Items	Order no.	Description
1	1	51006831-0024	Housing
2	1	51008941-0001	Plastic ring
3	2	51502120	Ball bearing
4	1	16047200072000	Securing ring
5	1	51502324	Gear belt
6	1	51004065-0001	Belt disk
7	1	1606885A080725-0001	Parallel key
8	1	51006600-0002	Bearing flange
9	1	16191200006030	Screw
10	2	16173490176530	Washer
11	1	16147100025000	Securing ring
12	1	16191200003010	Screw
13	3	16191200006090	Screw
14			Tool spindle
14	1	51005045-0001	MT2
	1	51003465-0001	MT3
	1	51003475-0002	ISO30
16	2	51502115	Ball bearing
17	1	51003475-0001	Sleeve
19	1	51004050-0007	Nut, thin
20	1	51004050-0008	Nut, thick
21	1	51003910-0003	Parallel key
22	1	51004030-0007	Gear shaft
24	2	16191200006100	Screw
25	2	51004025-0023	Spacer
26	1	51500102-0001	Motor with gear wheel
	1	51500108-0001	2 carbon brushes with brush holder
27	1	51006575-0002	Hub
28	1	51401148	Activation lever
29	1	51507039	Cylinder knob
30	1	16073430004028	Spiral tensioning pin
31	1	51006555-0005	Scale ring
32	1	16184000004025	Screw
33	1	16047100020000	Securing ring
34	1	16191200004025	Screw
36	1	16193300006016	Screw
37	1	51401150-0001	Depth stop
38	1	51502033	Spiral flat spring
39	1	51507014	Clamping lever
40	1	51004008-0002	Mounting pin

17. Drawings and legends

17.4 Milling head with 2.0 kW motor

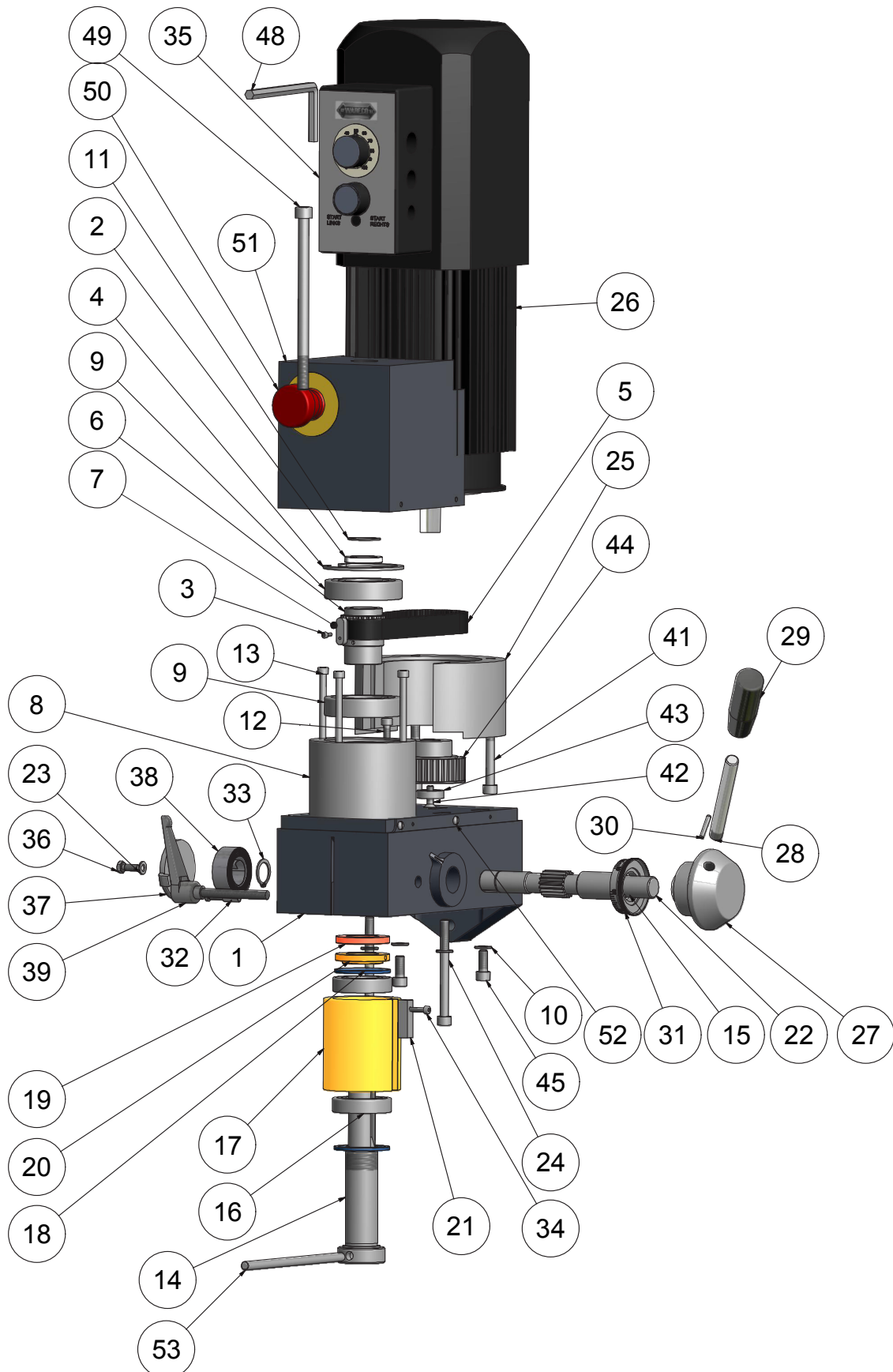

17. Drawings and legends

17.4 Milling head with 2.0 kW motor

Part no.	Items	Order no.	Description
1	1	51006831-0024	Housing
2	1	51008941-0001	Plastic ring
3	1	16191200003010	Screw
4	1	16047200072000	Securing ring
5	1	51502327	Gear belt
6	1	51004801-0008	Belt disk
7	1	1606885A080725-0001	Parallel key
8	1	51006600-0002	Bearing flange
9	2	51502120	Ball bearing
10	4	16112500008001	Washer
11	1	16147100025000	Securing ring
12	1	16191200006030	Screw
13	3	16191200006090	Screw
14			Tool spindle
14	1	51005045-0001	MT2
	1	51003465-0001	MT3
	1	51003475-0002	ISO30
15	1	51007970-0002	Spring wire
16	2	51502135	Ball bearing
17	1	51003475-0001	Sleeve
18	2	51502200	Nilos ring
19	1	51004050-0007	Nut, thin
20	1	51004050-0008	Nut, thick
21	1	51003910-0003	Parallel key
22	1	51004030-0007	Gear shaft
24	2	16191200008090	Screw
25	1	51006650-0003	Flange
26	1	51500128-0002	Motor 2.0 kW
27	1	51006575-0002	Hub
28	1	51401148	Activation lever
29	1	51507039	Cylinder knob
30	1	16073430004028	Spiral tensioning pin
31	1	51006555-0005	Scale ring
32	1	16184000004025	Screw
33	1	16047100020000	Securing ring
34	1	16191200004025	Screw

17. Drawings and legends

17.4 Milling head with 2.0 kW motor

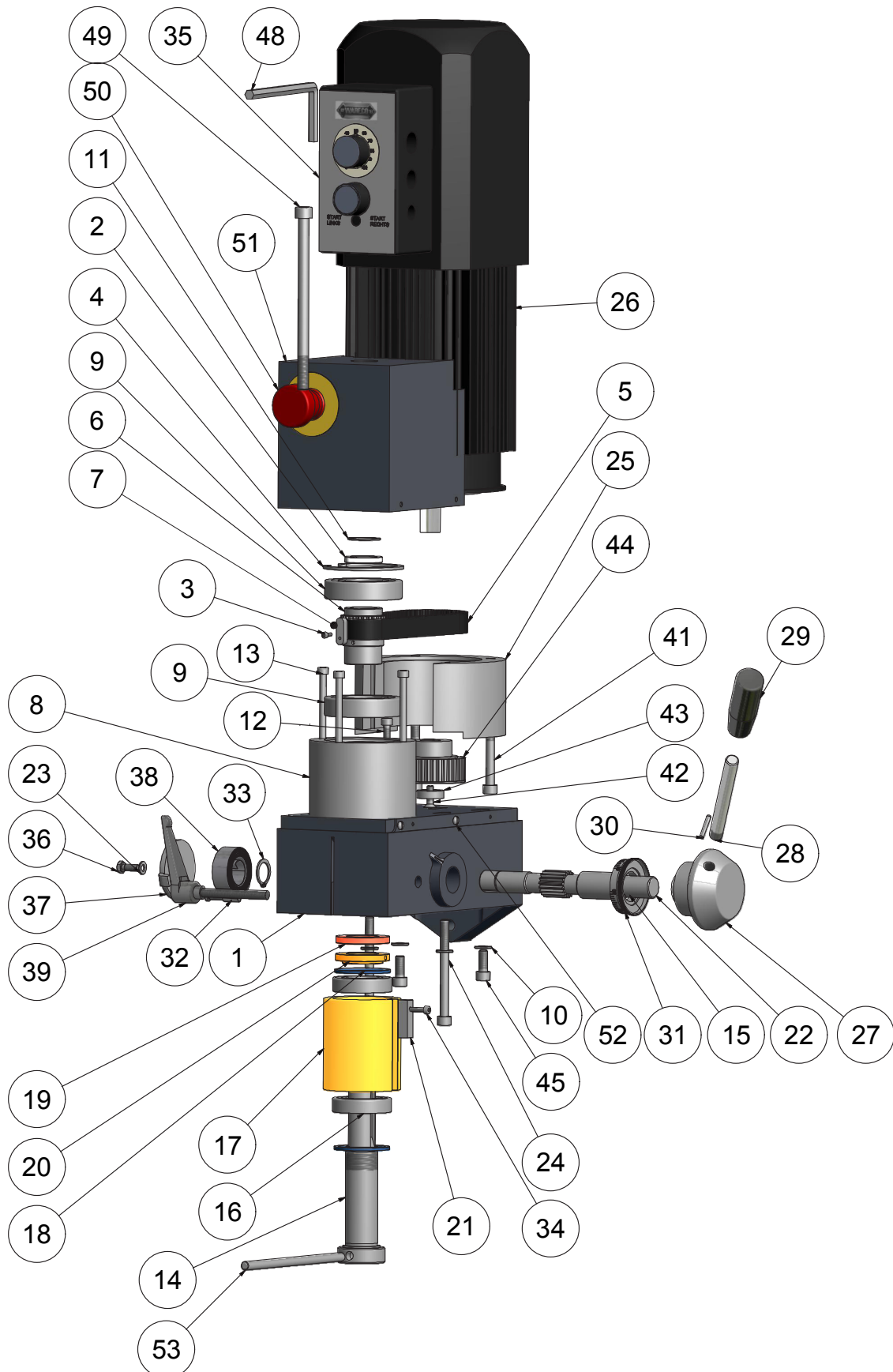

17. Drawings and legends

17.4 Milling head with 2.0 kW motor

Part no.	Items	Order no.	Description
36	1	16193300006016	Screw
37	1	51401150-0001	Depth stop
38	1	51502033	Spiral flat spring
39	1	51507014	Tensioning lever
41	2	16191200008070	Screw
42	1	16191200006020	Screw
43	1	51004025-0024	Pressure washer
44	1	51004065-00031	Gear wheel motor
45	2	16191200008020	Screw
48			Allen key
48	1	51007430-0002	8 mm for tool tightening screw MT2
	1	51007440-0002	10 mm for tool tightening screw MT3 or ISO30
49			Tool tightening screw
49	1	91200010130-01	with thread M10 to MT2
	1	91200012160-01	with thread M12 to MT3 or ISO30
52	4	16191200004010	Screw
53	1	51004008-0002	Mounting pin
			 F1200 hs - F1210 hs F1200-C hs - F1210-C hs
35	1	51500127	Terminal box lid with control elements
50	1	51500624-0001	Emergency off switch, complete
51	1	51401203-0001	Cover hood
			 CC-F1200 hs - CC-F1210 hs
35	1	51500133	Terminal box lid without control elements
51	1	51401204-0001	Cover hood

17. Drawings and legends

17.5 Z-column with vertical slide with trapezoidal thread spindle

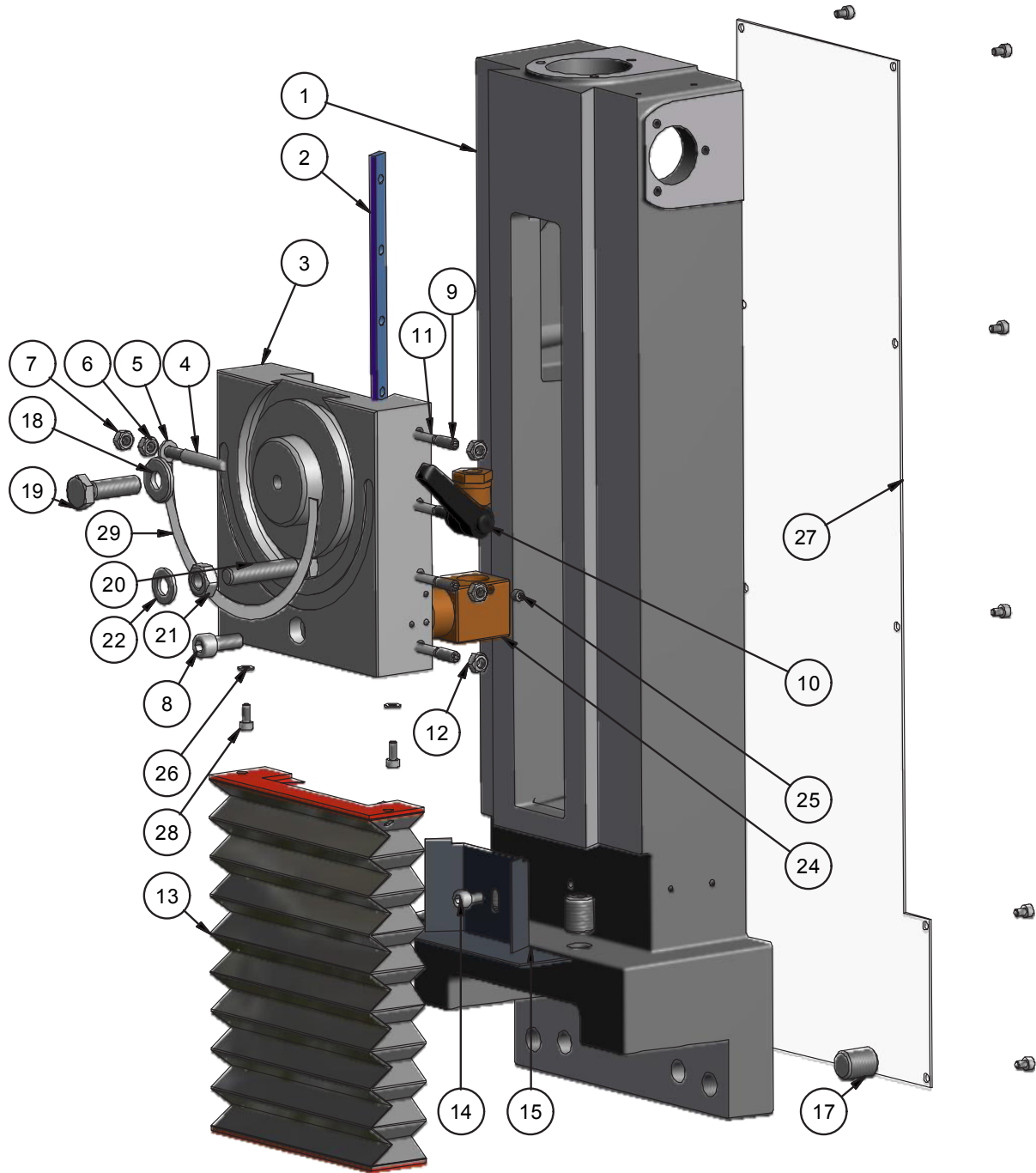

17. Drawings and legends

17.5 Z-column with vertical slide with trapezoidal thread spindle

Part no.	Items	Order no.	Description
1	1	51401142-00011	Z-column
2	1	51001016-0007	Adjustment bar
3	1	51401147-0001	Vertical slide
4	1	16079770006060	Index bolt
5	2	16112500006001	Washer
6	1	16193400006000	Nut
7	1	16198500006000	Nut
8	1	16191200008025	Screw
9	4	16091300006016	Threaded pin
10	1	51507029	Tensioning lever
11	5	16063250005022	Push piece
12	4	16193400006000	Nut
13	1	51502520-0001	Bellows, Z-axis
14	1	16191200006010	Screw
15	1	51401103-0001	Bellows guide
17	2	16091300016020	Threaded pin
18	1	51004050-0006	Washer
19	1	16193300010035	Screw
20	1	16193300010050	Screw
21	1	16193400010000	Nut
22	1	16112500010000	Washer
24	1	51007348-00031	Spindle nut with adjustment nut, right
25	1	16091300006006	Threaded pin
26	2	16112500004000	Washer
27	1	51401102-0001	Cover plate
28	12	16191200004010	Screw
29	1	51503015	Aluminum scale

17. Drawings and legends

17.6 Spindle Z-axis with trapezoidal thread spindle

17.6.1 F1200 – F1200 hs – F1210 – F1210 hs

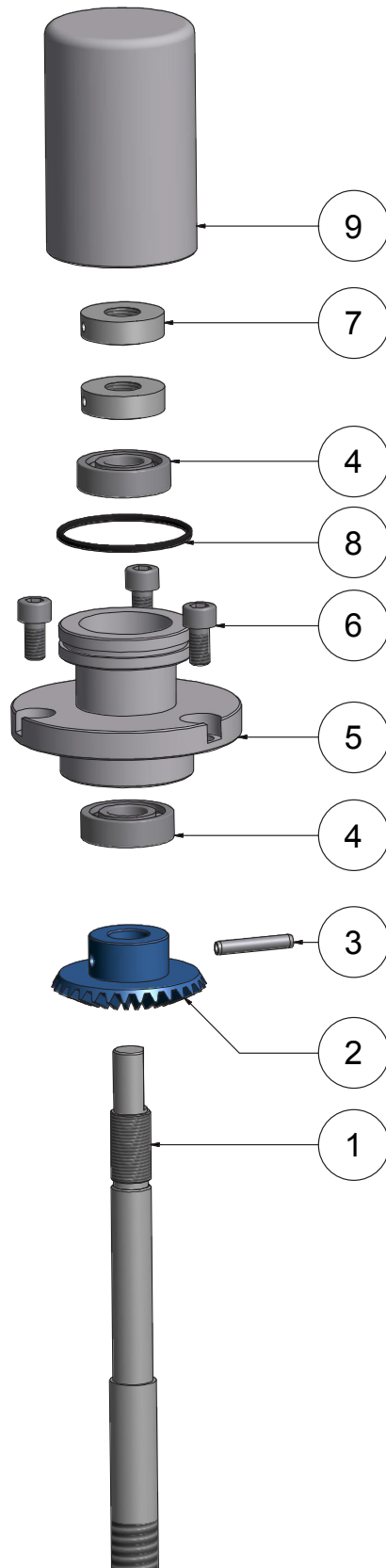

17. Drawings and legends

17.6 Spindle Z-axis with trapezoidal thread spindle

17.6.1 F1200 – F1200 hs – F1210 – F1210 hs

Part no.	Items	Order no.	Description
1	1	51502550-0001	Spindle
2	1	51502404-0001	Bevel gear
3	1	16073430004024	Spiral tensioning pin
4	2	51502112	Ball bearing
5	1	51004070-0001	Spindle flange
6	3	16191200006012	Screw
7	2	51004025-0025	Setting nut
8	1	51502208	O ring
9	1	51006545-0002	Cover cap

17. Drawings and legends

17.6 Spindle Z-axis with trapezoidal thread spindle

17.6.2 F1200-C – F1200-C hs – F1210-C – F1210-C hs
CC-F1200 – CC-F1200 hs – CC-F1210 – CC-F1210 hs

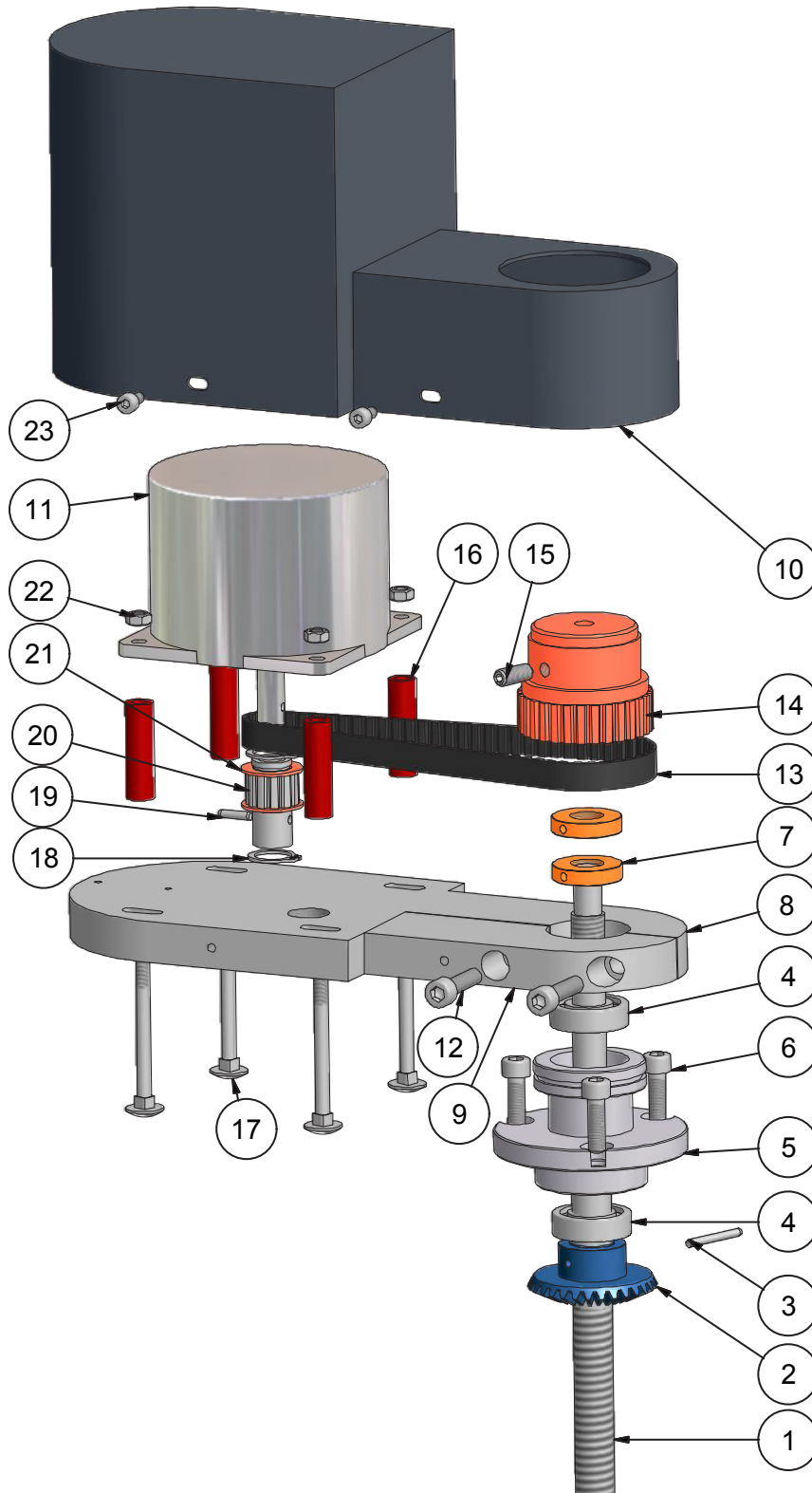

17. Drawings and legends

17.6 Spindle Z-axis with trapezoidal thread spindle

17.6.2 F1200-C – F1200-C hs – F1210-C – F1210-C hs CC-F1200 – CC-F1200 hs – CC-F1210 – CC-F1210 hs

Part no.	Items	Order no.	Description
1	1	51502550-0001	Spindle
2	1	51502404-0001	Bevel gear
3	1	16073430004024	Spiral tensioning pin
4	2	51502112	Ball bearing
5	1	51004070-0001	Spindle flange
6	3	16191200006012	Screw
7	2	51004025-0025	Setting nut
8	1	51401422-0001	Motor holder
9	1	51401426-0001	Clamp motor holder
10	1	51401501-0001	Cover hood
11	1	51500122	Stepper motor
12	2	16191200006030	Screw
13	1	51502323	Gear belt
14	1	51004050-0010	Gear belt pulley
15	1	16091300006016	Threaded pin
16	4	51004010-0021	Spacer, stepper motor
17	4	16160300005060	Screw
18	2	16047100014000	Securing ring
19	1	16073430003014	Spiral tensioning pin
20	1	51004020-0002	Belt disk
21	2	16000002214010	Adjusting washer
22	4	16193400005000	Nut
23	4	16191200004010	Screw

17. Drawings and legends

17.7 Lateral drive for Z-axis with trapezoidal thread spindle

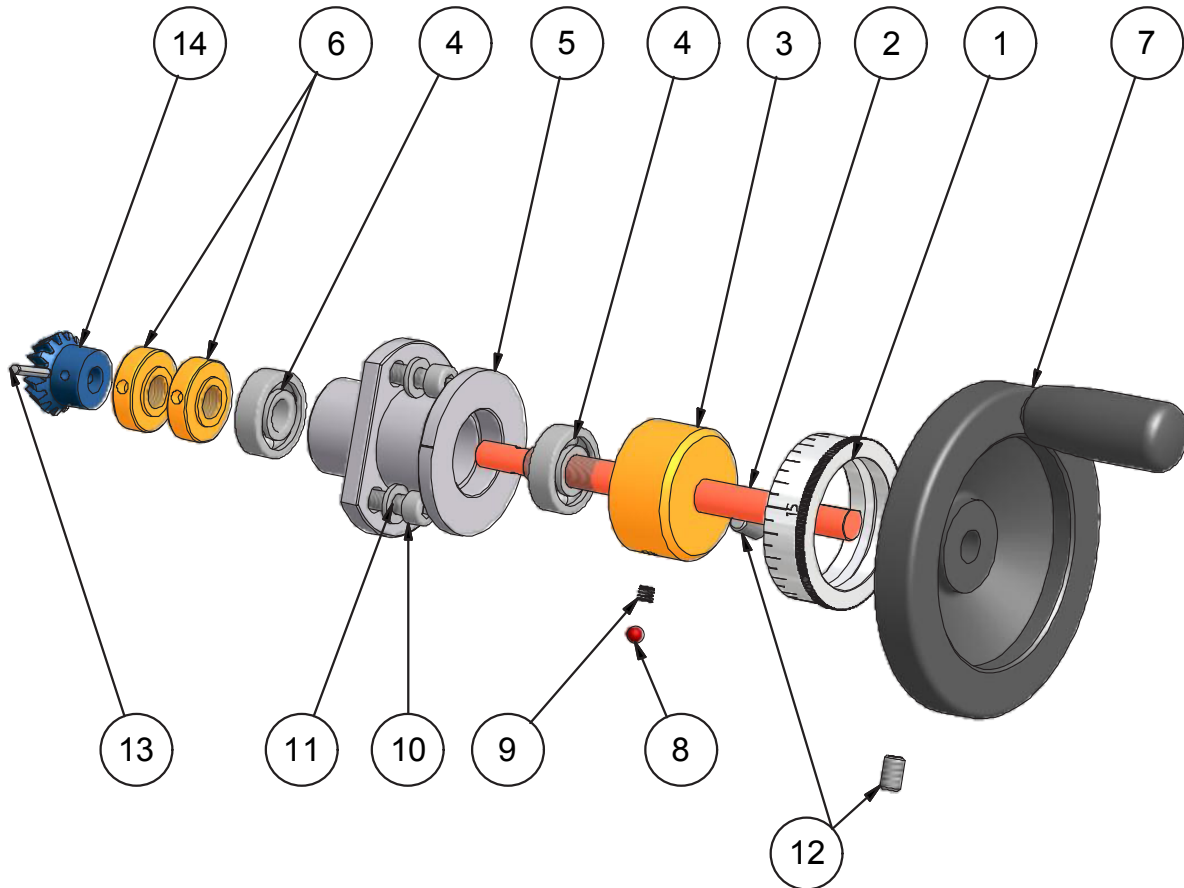

17. Drawings and legends

17.7 Lateral drive for Z-axis with trapezoidal thread spindle

Part no.	Items	Order no.	Description
1	1	51006750-00020	Scale ring (40 intervals)
2	1	51004010-0004	Spindle
3	1	51004040-0010	Adjusting ring
4	2	51502111	Ball bearing
5	1	51004060-0001	Spindle flange
6	2	51004025-0027	Setting nut
8	1	51502131	Steel ball
9	1	51502027-0001	Pressure spring
10	3	16191200006020	Screw
11	3	16112500006001	Washer
12	2	16091300006006	Threaded pin
13	1	16073430003018	Spiral tensioning pin
14	1	51502405	Bevel gear
			F1200 - F1200 hs - F1210 - F1210 hs
7	1	51507026-0001	Hand wheel
			F1200-C - F1200-C hs - F1210-C - F1210-C hs
			CC-F1200 - CC-F1200 hs - CC-F1210 - CC-F1210 hs
7	1	51507027-0001	Hand wheel

17. Drawings and legends

17.8 Cross slide support with trapezoidal thread spindle

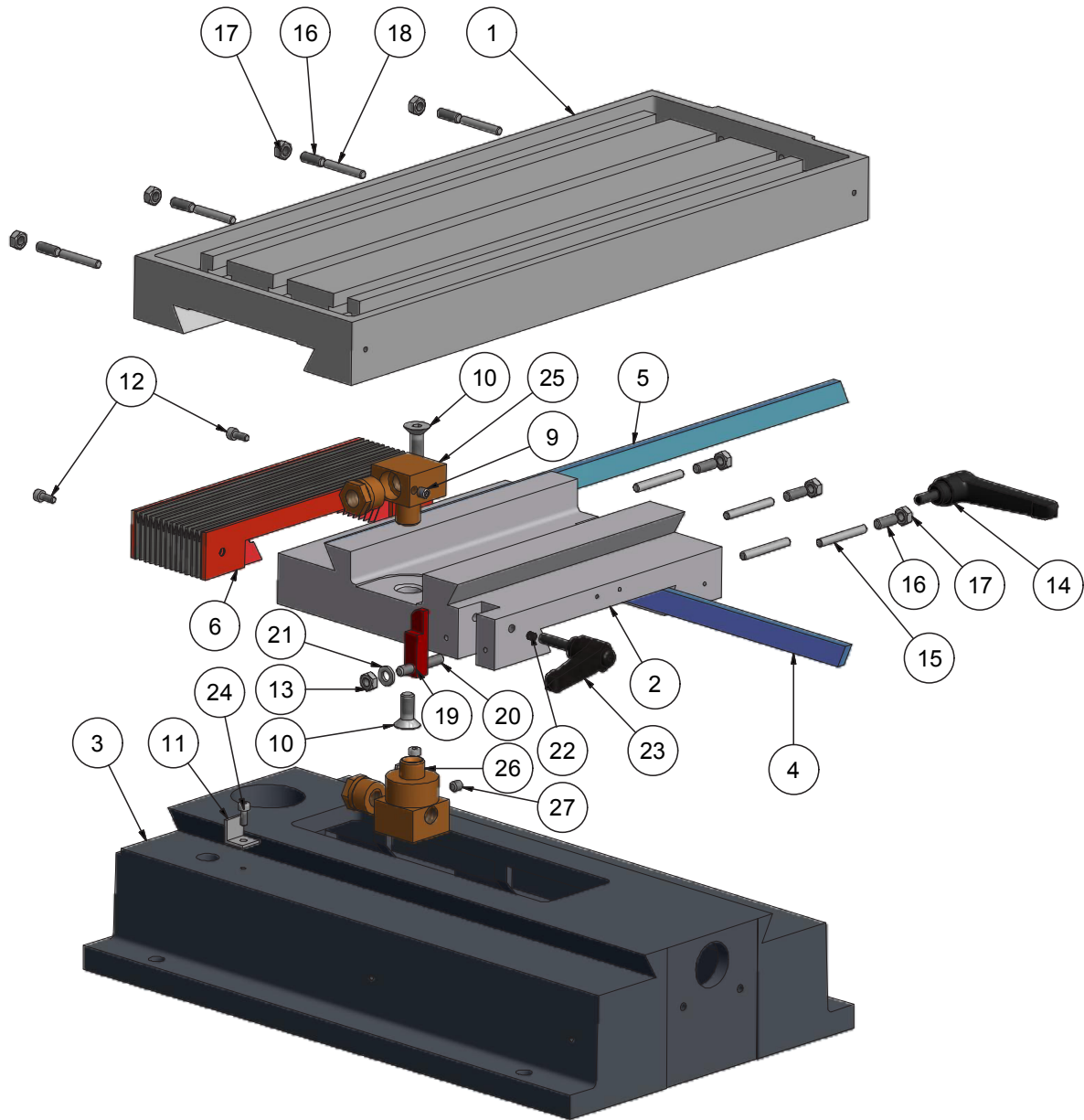

17. Drawings and legends

17.8 Cross slide support with trapezoidal thread spindle

Part no.	Items	Order no.	Description
2	1	51401140-0001	Cross skid
3	1	51401146-00011	Base plate
4	1	51001016-0001	Adjustment bar
6	1	51502521	Bellows
10	2	16079910008020	Screw
11	2	51401121	Aluminum bracket
12	2	16191200004010	Screw
13	1	16198500006000	Nut
14	1	51507029	Clamping lever
15	4	16063250005040	Push piece
19	1	51003910-0001	Clamping piece
20	1	16083500006025	Screw
21	1	16112500006001	Washer
22	1	51502027	Pressure spring
23	1	51507030	Clamping lever
24	2	16196500004008	Screw
25	1	51007348-00011	Spindle nut with adjustment nut, right
26	1	51007348-00021	Spindle nut with adjustment nut, left
27	2	16091300006006	Threaded pin

F1200 - F1200 hs

F1200-C - F1200-C hs

CC-F1200 – CC-F1200 hs

1	1	51401141-0001	Top skid
5	1	51001016-0002	Adjustment bar
16	7	16091300006016	Threaded pin
17	7	16193400006000	Nut
18	4	16063250005032	Push piece

F1210 - F1210 hs

F1210-C - F1210-C hs

CC-F1210 – CC-F1210 hs

1	1	51401240-0001	Top skid
5	1	51001016-0004	Adjustment bar
16	9	16091300006016	Threaded pin
17	9	16193400006000	Nut
18	6	16063250005032	Push piece

17. Drawings and legends

17.9 Spindle X-axis with trapezoidal thread spindle

17.9.1 F1200 – F1200 hs – F1210 – F1210 hs

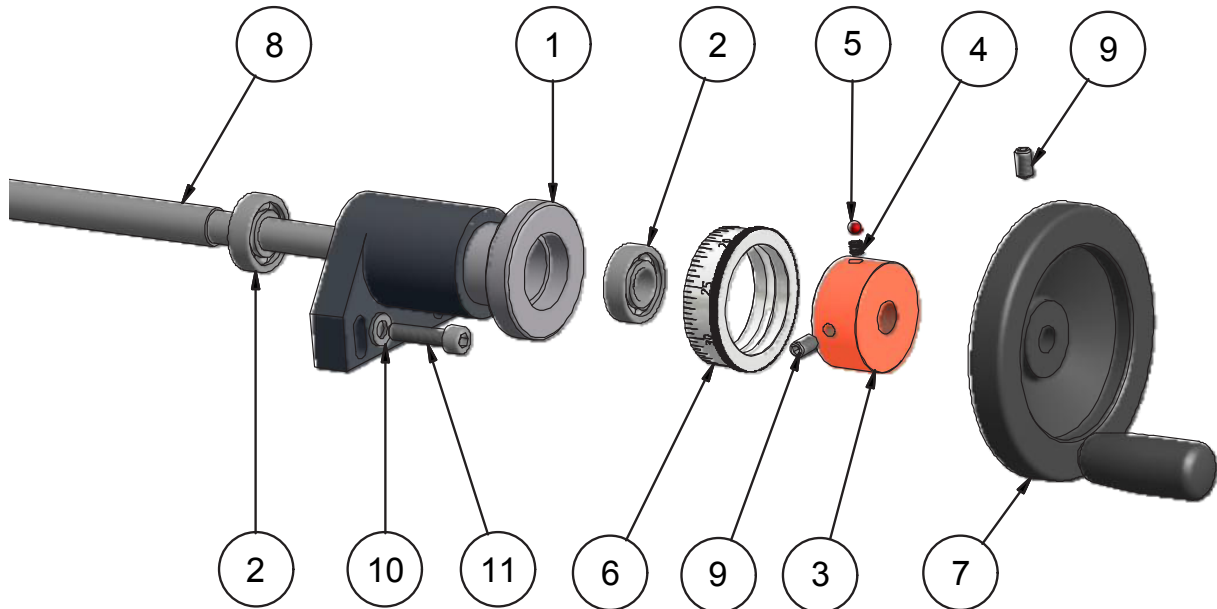

17. Drawings and legends

17.9 Spindle X-axis with trapezoidal thread spindle

17.9.1 F1200 – F1200 hs – F1210 – F1210 hs

Part no.	Items	Order no.	Description
1	1	51401155-00011	Spindle bearing
2	2	51502112	Ball bearing
3	1	51004040-0003	Adjusting ring
4	1	51502027-0001	Pressure spring
5	1	51502131	Steel ball
6	1	51006750-00011	Scale ring (80 intervals)
7	1	51507026-0001	Hand wheel
9	2	16091300006006	Threaded pin
10	2	16112500006001	Washer
11	2	16191200006025	Screw
			F1200 – F1200 hs
8	1	51502551-0001	Spindle
			F1210 – F1210 hs
8	1	51502552-0001	Spindle

17. Drawings and legends

17.9 Spindle X-axis with trapezoidal thread spindle

17.9.2 F1200-C – F1200-C hs – F1210-C – F1210-C hs
CC-F1200 – CC-F1200 hs – CC-F1210 – CC-F1210 hs

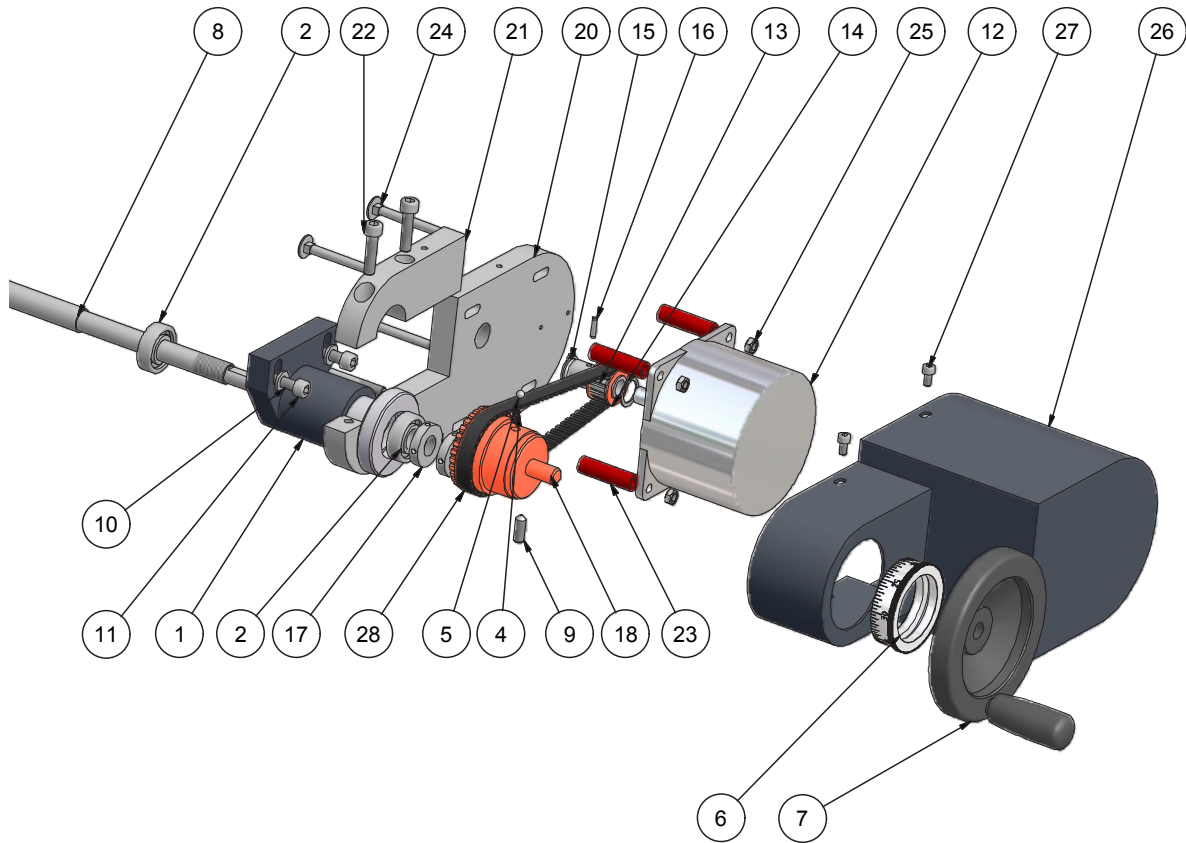

17. Drawings and legends

17.9 Spindle X-axis with trapezoidal thread spindle

17.9.2 F1200-C – F1200-C hs – F1210-C – F1210-C hs CC-F1200 – CC-F1200 hs – CC-F1210 – CC-F1210 hs

Part no.	Items	Order no.	Description
1	1	51401155-00011	Spindle bearing
2	2	51502112	Ball bearing
4	1	51502027-0001	Pressure spring
5	1	51502131	Steel ball
6	1	51006750-00011	Scale ring (80 intervals)
7	1	51507027-0001	Hand wheel
9	1	16091300006010	Threaded pin
10	2	16112500006001	Washer
11	2	16191200006025	Screw
12	1	51500122	Stepper motor
13	1	51004020-0002	Belt disk
14	2	16000002214010	Adjusting washer
15	2	16047100014000	Securing ring
16	1	16073430003014	Spiral tensioning pin
18	1	51004050-0009	Gear belt pulley
20	1	51401422-0001	Motor holder
21	1	51401426-0001	Clamp to motor holder
22	2	16191200006030	Screw
23	4	51004010-0021	Spacer, stepper motor
24	4	16160300005060	Screw
25	4	16193400005000	Nut
26	1	51401501-0001	Cover hood for stepper motor
27	4	16191200004010	Screw
28	1	51502323	Gear belt
			F1200-C - F1200-C hs CC-F1200 – CC-F1200 hs
8	1	51502551-0001	Spindle
			F1210-C - F1210-C hs CC-F1210 – CC-F1210 hs
8	1	51502552-0001	Spindle

17. Drawings and legends

17.10 Spindle Y-axis with trapezoidal thread spindle

17.10.1 F1200 – F1200 hs – F1210 – F1210 hs

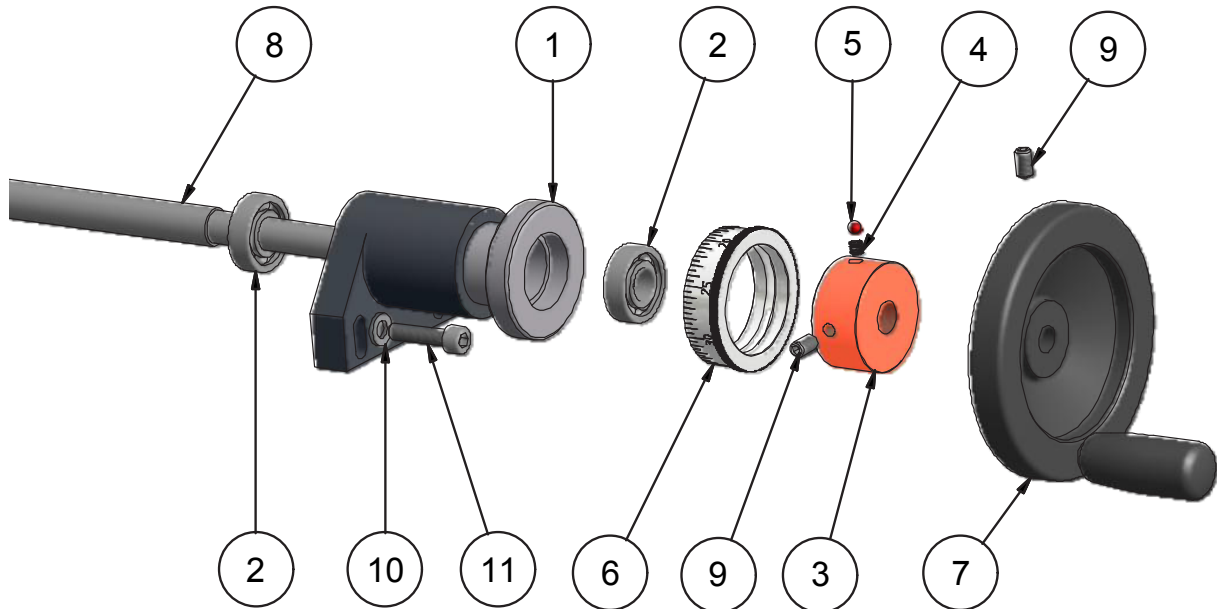

17. Drawings and legends

17.10 Spindle Y-axis with trapezoidal thread spindle

17.10.1 F1200 – F1200 hs – F1210 – F1210 hs

Part no.	Items	Order no.	Description
1	1	51401155-00011	Spindle bearing
2	2	51502112	Grooved ball bearing
3	1	51004040-0003	Adjusting ring
4	1	51502027-0001	Pressure spring
5	1	51502131	Steel ball
6	1	51006750-00011	Scale ring (80 intervals)
7	1	51507026-0001	Hand wheel
9	2	16091300006006	Threaded pin
10	2	16112500006001	Washer
11	2	16191200006025	Screw
			F1200 - F1200 hs
			F1210 - F1210 hs
8	1	51502553-0001	Spindle
			For transverse extension
8	1	51502554-00011	Spindle

17. Drawings and legends

17.10 Spindle Y-axis with trapezoidal thread spindle

17.10.2 F1200-C – F1200-C hs – F1210-C – F1210-C hs
CC-F1200 – CC-F1200 hs – CC-F1210 – CC-F1210 hs

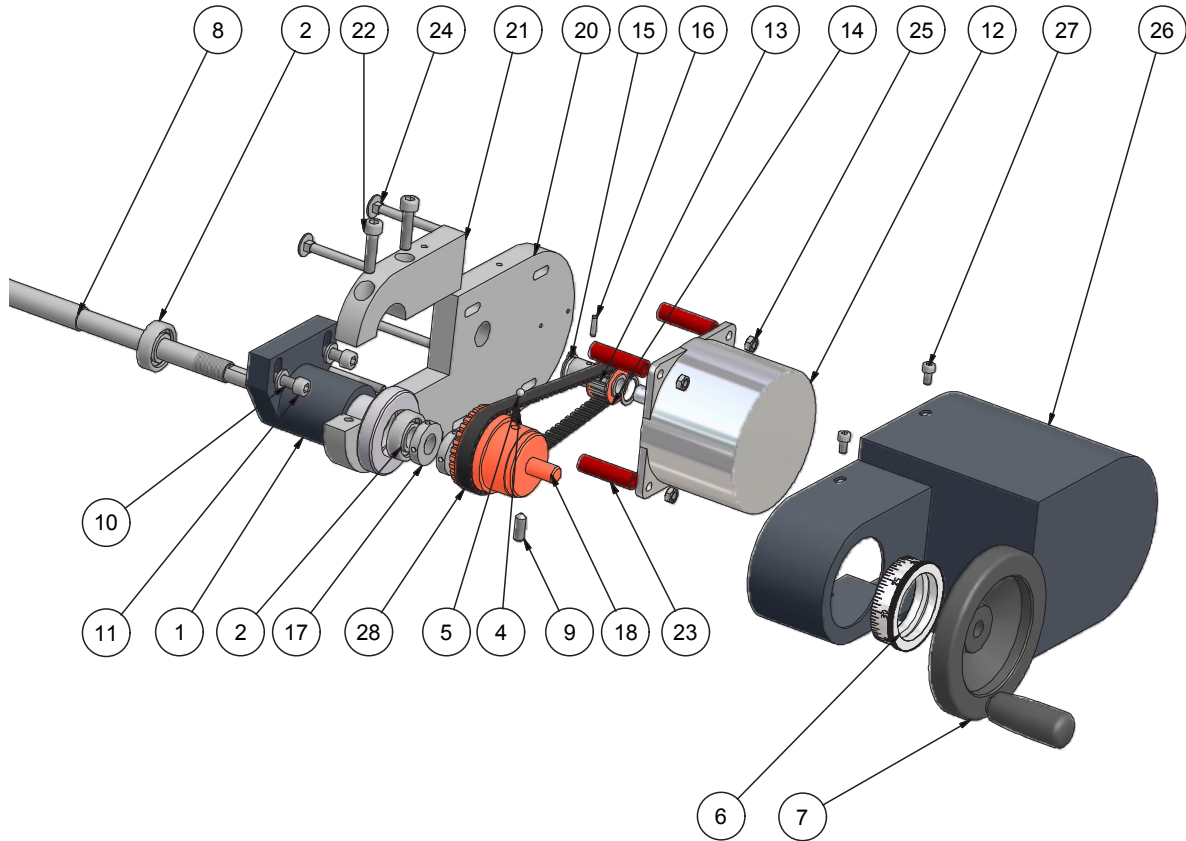

17. Drawings and legends

17.10 Spindle Y-axis with trapezoidal thread spindle

17.10.2 F1200-C – F1200-C hs – F1210-C – F1210-C hs CC-F1200 – CC-F1200 hs – CC-F1210 – CC-F1210 hs

Part no.	Items	Order no.	Description
1	1	51401155-00011	Spindle bearing
2	2	51502112	Grooved ball bearing
4	1	51502027-0001	Pressure spring
5	1	51502131	Steel ball
6	1	51006750-00011	Scale ring (80 intervals)
7	1	51507027-0001	Hand wheel
9	1	16091300006010	Threaded pin
10	2	16112500006001	Washer
11	2	16191200006025	Screw
12	1	51500122	Stepper motor
13	1	51004020-0002	Belt disk
14	2	16000002214010	Adjusting washer
15	2	16047100014000	Securing ring
16	1	16073430003014	Spiral tensioning pin
18	1	51004050-0009	Gear belt pulley
20	1	51401422-0001	Motor holder
21	1	51401426-0001	Clamp to motor holder
22	2	16191200006030	Screw
23	4	51004010-0021	Spacer, stepper motor
24	4	16160300005060	Screw
25	4	16193400005000	Nut
26	1	51401501-0001	Cover hood for stepper motor
27	4	16191200004010	Screw
28	1	51502323	Gear belt
			F1200-C - F1200-C hs CC-F1200 – CC-F1200 hs F1210-C - F1210-C hs CC-F1210 – CC-F1210 hs
8	1	51502553-0001	Spindle
			For transverse extension
8	1	51502554-00011	Spindle

17. Drawings and legends

17.11 Z-column with vertical slide with ball screw

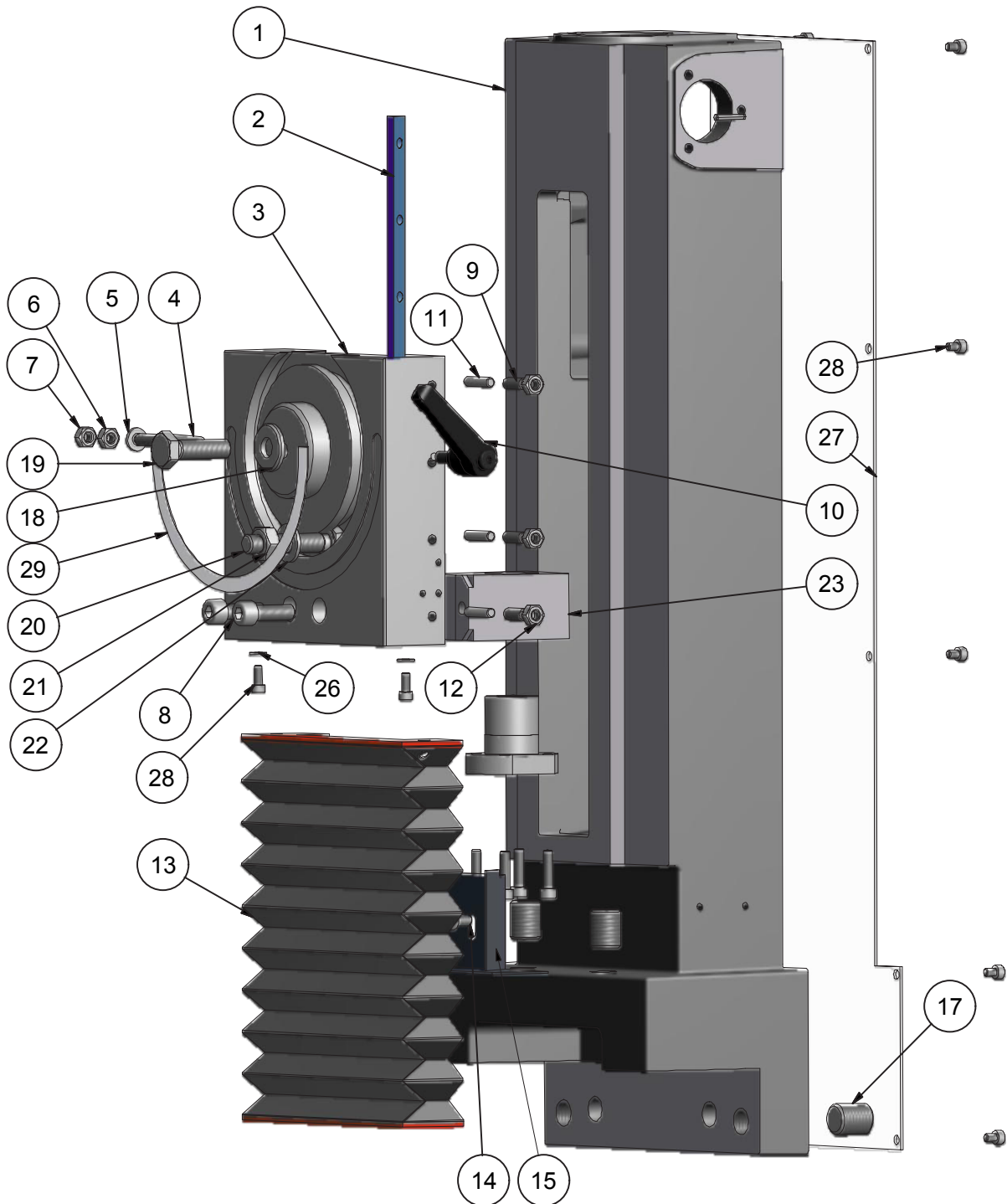

17. Drawings and legends

17.11 Z-column with vertical slide with ball screw

Part no.	Items	Order no.	Description
1	1	51401142-00011	Z-column
2	1	51001016-0007	Adjustment bar
3	1	51401147-0002	Vertical slide
4	1	16079770006060	Index bolt
5	2	16112500006001	Washer
6	1	16193400006000	Nut
7	1	16198500006000	Nut
8	2	16191200008025	Screw
9	4	16091300006016	Threaded pin
10	1	51507029	Tensioning lever
11	5	16063250005022	Push piece
12	4	16193400006000	Nut
13	1	51502520-0001	Bellows, Z-axis
14	1	16191200006010	Screw
15	1	51401103-0001	Bellows guide
17	2	16091300016020	Threaded pin
18	1	51004050-0006	Washer
19	1	16193300010035	Screw
20	1	16193300010050	Screw
21	1	16193400010000	Nut
22	1	16112500010000	Washer
23	1	51505242	Nut holder
26	2	16112500004000	Washer
27	1	51401102-0001	Cover plate
28	12	16191200004010	Screw
29	1	51503015	Aluminum scale

17. Drawings and legends

17.12 Spindle Z-axis with ball screw

17.12.1 F1200 – F1200 hs – F1210 – F1210 hs

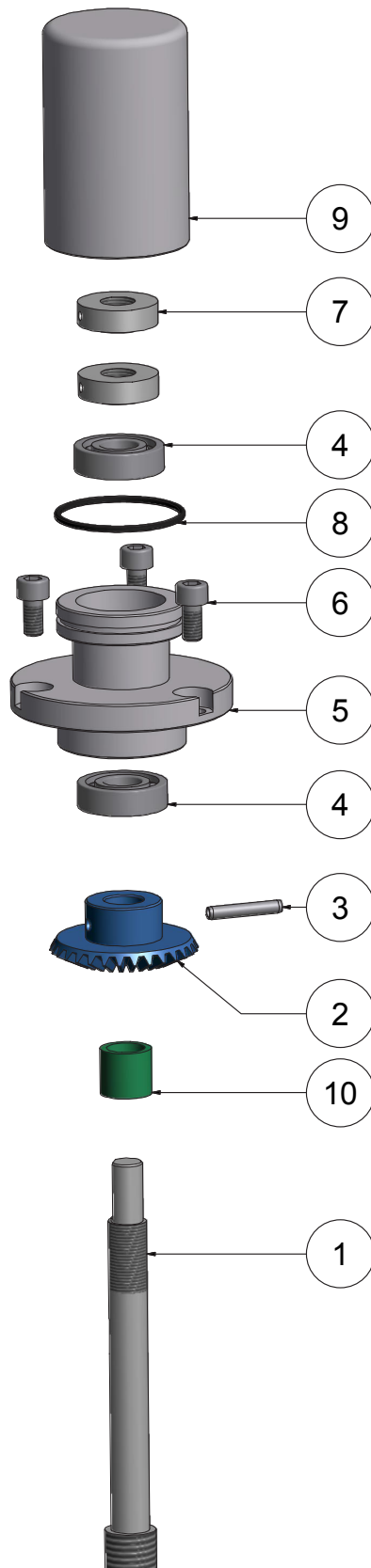

17. Drawings and legends

17.12 Spindle Z-axis with ball screw

17.12.1 F1200 – F1200 hs – F1210 – F1210 hs

Part no.	Items	Order no.	Description
1	1	51505210-0003	Spindle with spindle nut
2	1	51502404-0001	Bevel gear
3	1	16073430004024	Spiral tensioning pin
4	2	51502112	Ball bearing
5	1	51004070-0001	Spindle flange
6	3	16191200006012	Screw
7	2	51004025-0025	Setting nut
8	1	51502208	O ring
9	1	51006545-0002	Cover cap
10	1	51004016-0005	Spacer

17. Drawings and legends

17.12 Spindle Z-axis with ball screw

17.12.2 F1200-C – F1200-C hs – F1210-C – F1210-C hs
CC-F1200 – CC-F1200 hs – CC-F1210 – CC-F1210 hs

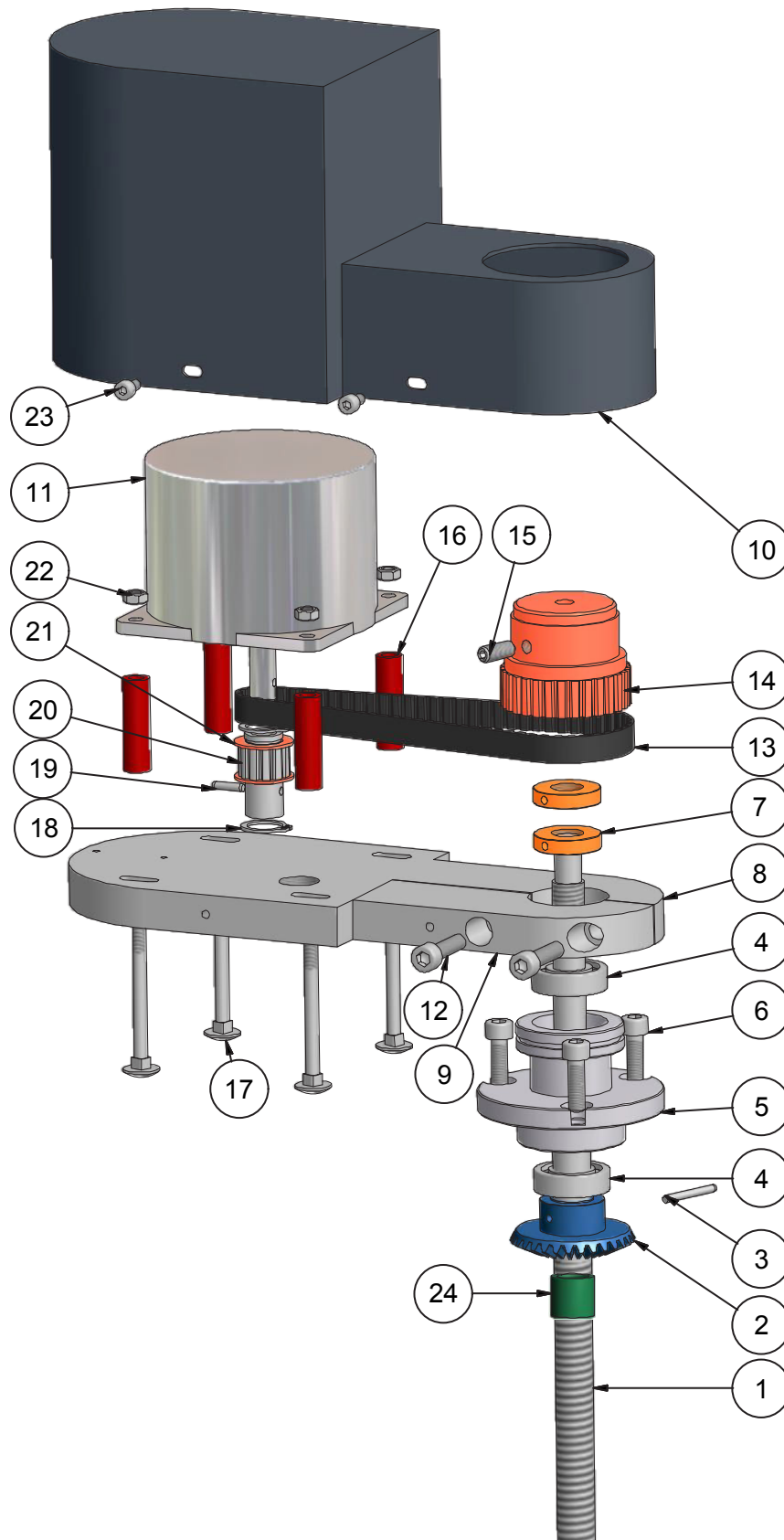

17. Drawings and legends

17.12 Spindle Z-axis with ball screw

17.12.2 F1200-C – F1200-C hs – F1210-C – F1210-C hs CC-F1200 – CC-F1200 hs – CC-F1210 – CC-F1210 hs

Part no.	Items	Order no.	Description
1	1	51505210-0003	Spindle with spindle nut
2	1	51502404-0001	Bevel gear
3	1	16073430004024	Spiral tensioning pin
4	2	51502112	Ball bearing
5	1	51004070-0001	Spindle flange
6	3	16191200006012	Screw
7	2	51004025-0025	Setting nut
8	1	51401422-0001	Motor holder
9	1	51401426-0001	Clamp motor holder
10	1	51401501-0001	Cover hood
11	1	51500122	Stepper motor
12	2	16191200006030	Screw
13	1	51502323	Gear belt
14	1	51004050-0010	Gear belt pulley
15	1	16091300006016	Threaded pin
16	4	51004010-0021	Spacer, stepper motor
17	4	16160300005060	Screw
18	2	16047100014000	Securing ring
19	1	16073430003014	Spiral tensioning pin
20	1	51004020-0002	Belt disk
21	2	16000002214010	Adjusting washer
22	4	16193400005000	Nut
23	4	16191200004010	Screw
24	1	51004016-0005	Spacer

17. Drawings and legends

17.13 Lateral drive for Z-axis with ball screw



17. Drawings and legends

17.13 Lateral drive for Z-axis with ball screw

Part no.	Items	Order no.	Description
	1	51006750-00021	Scale ring (50 intervals)
2	1	51004010-0004	Spindle
3	1	51004040-0010	Adjusting ring
4	2	51502111	Ball bearing
5	1	51004060-0001	Spindle flange
6	2	51004025-0027	Setting nut
8	1	51502131	Steel ball
9	1	51502027-0001	Pressure spring
10	3	16191200006020	Screw
11	3	16112500006001	Washer
12	2	16091300006006	Threaded pin
13	1	16073430003018	Spiral tensioning pin
14	1	51502405	Bevel gear
			F1200 - F1200 hs - F1210 - F1210 hs
7	1	51507026-0001	Hand wheel
			F1200-C - F1200-C hs - F1210-C - F1210-C hs
			CC-F1200 - CC-F1200 hs - CC-F1210 - CC-F1210 hs
7	1	51507027-0001	Hand wheel

17. Drawings and legends

17.14 Cross slide support with ball screw

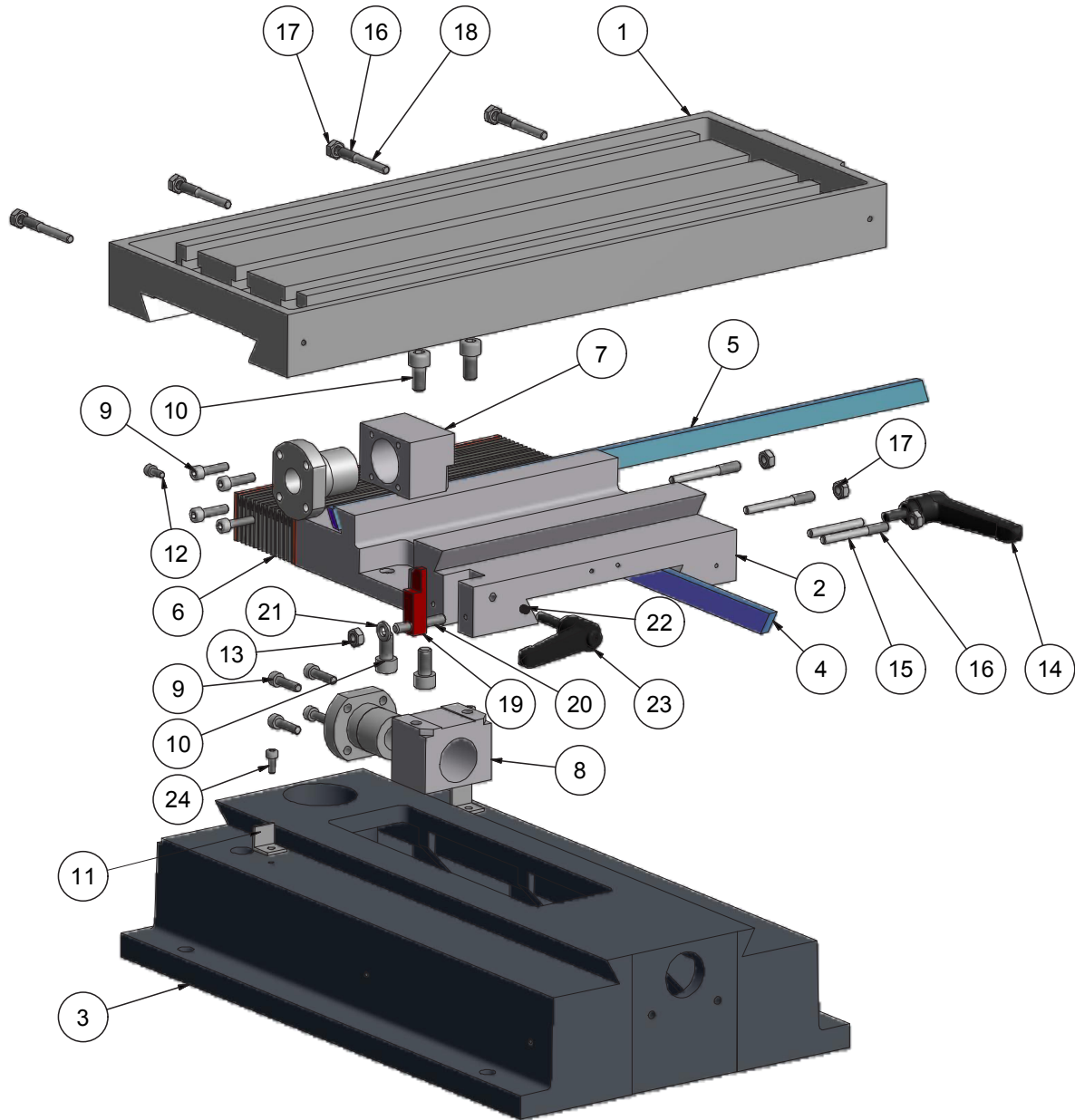

17. Drawings and legends

17.14 Cross slide support with ball screw

Part no.	Items	Order no.	Description
2	1	51401140-0002	Cross skid
3	1	51401146-00011	Base plate
4	1	51001016-0001	Adjustment bar
6	1	51502521	Bellows
9	8	16191200005020	Screw
10	4	16191200008020	Screw
11	2	51401121	Aluminum bracket
12	2	16191200004010	Screw
13	1	16198500006000	Nut
14	1	51507029	Clamping lever
15	4	16063250005040	Push piece
19	1	51003910-0001	Clamping piece
20	1	16083500006025	Screw
21	1	16112500006001	Washer
22	1	51502027	Pressure spring
23	1	51507030	Clamping lever
24	2	16196500004008	Screw
25	1	51505240	Nut holder, X-axis
26	1	51505241	Nut holder, Y-axis
			F1200 - F1200 hs
			F1200-C - F1200-C hs
			CC-F1200 – CC-F1200 hs
1	1	51401141-0001	Top skid
5	1	51001016-0002	Adjustment bar
16	7	16091300006016	Threaded pin
17	7	16193400006000	Nut
18	4	16063250005032	Push piece
			F1210 - F1210 hs
			F1210-C - F1210-C hs
			CC-F1210 – CC-F1210 hs
1	1	51401240-0001	Top skid
5	1	51001016-0004	Adjustment bar
16	9	16091300006016	Threaded pin
17	9	16193400006000	Nut
18	6	16063250005032	Push piece

17. Drawings and legends

17.15 Spindle X-axis with ball screw

17.15.1 F1200 – F1200 hs – F1210 – F1210 hs

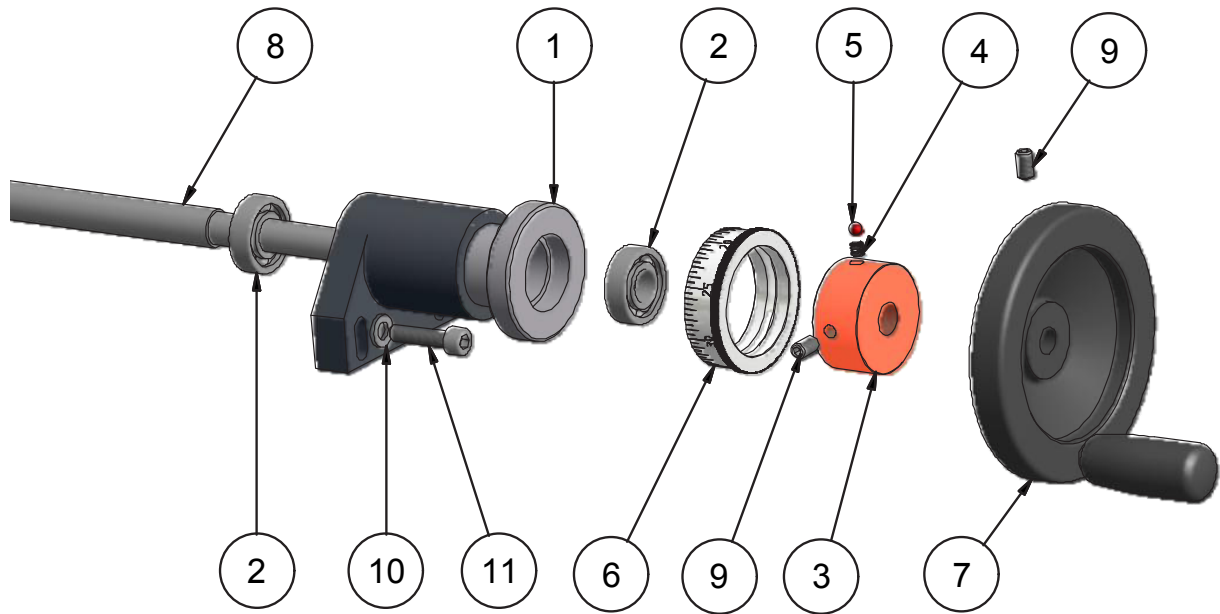

17. Drawings and legends

17.15 Spindle X-axis with ball screw

17.15.1 F1200 – F1200 hs – F1210 – F1210 hs

Part no.	Items	Order no.	Description
1	1	51401155-00011	Spindle bearing
2	2	51502112	Ball bearing
3	1	51004040-0003	Adjusting ring
4	1	51502027-0001	Pressure spring
5	1	51502131	Steel ball
6	1	51006750-00012	Scale ring (100 intervals)
7	1	51507026-0001	Hand wheel
9	2	16091300006006	Threaded pin
10	2	16112500006001	Washer
11	2	16191200006025	Screw
			F1200 - F1200 hs
8	1	51505210-0001	Spindle with spindle nut
			F1210 - F1210 hs
8	1	51505210-0004	Spindle with spindle nut

17. Drawings and legends

17.15 Spindle X-axis with ball screw

17.15.2 F1200-C – F1200-C hs – F1210-C – F1210-C hs
CC-F1200 – CC-F1200 hs – CC-F1210 – CC-F1210 hs

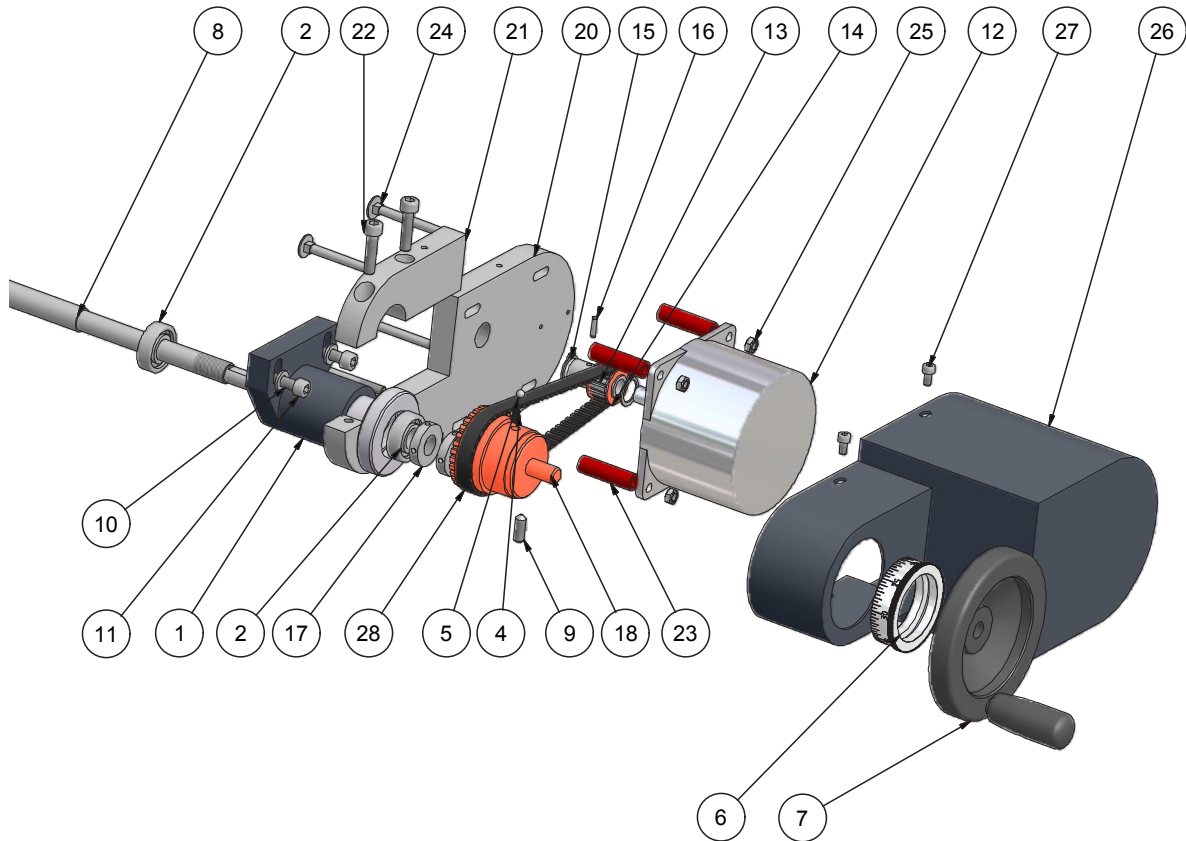

17. Drawings and legends

17.15 Spindle X-axis with ball screw

17.15.2 F1200-C – F1200-C hs – F1210-C – F1210-C hs CC-F1200 – CC-F1200 hs – CC-F1210 – CC-F1210 hs

Part no.	Items	Order no.	Description
1	1	51401155-00011	Spindle bearing
2	2	51502112	Ball bearing
4	1	51502027-0001	Pressure spring
5	1	51502131	Steel ball
6	1	51006750-00012	Scale ring (100 intervals)
7	1	51507027-0001	Hand wheel
9	1	16091300006010	Threaded pin
10	2	16112500006001	Washer
11	2	16191200006025	Screw
12	1	51500122	Stepper motor
13	1	51004020-0002	Belt disk
14	2	16000002214010	Adjusting washer
15	2	16047100014000	Securing ring
16	1	16073430003014	Spiral tensioning pin
18	1	51004050-0009	Gear belt pulley
20	1	51401422-0001	Motor holder
21	1	51401426-0001	Clamp to motor holder
22	2	16191200006030	Screw
23	4	51004010-0021	Spacer, stepper motor
24	4	16160300005060	Screw
25	4	16193400005000	Nut
26	1	51401501-0001	Cover hood for stepper motor
27	4	16191200004010	Screw
28	1	51502323	Gear belt
			F1200-C - F1200-C hs CC-F1200 – CC-F1200 hs
8	1	51505210-0001	Spindle with spindle nut
			F1210-C - F1210-C hs CC-F1210 – CC-F1210 hs
8	1	51505210-0004	Spindle with spindle nut

17. Drawings and legends

17.16 Spindle Y-axis with ball screw

17.16.1 F1200 – F1200 hs – F1210 – F1210 hs

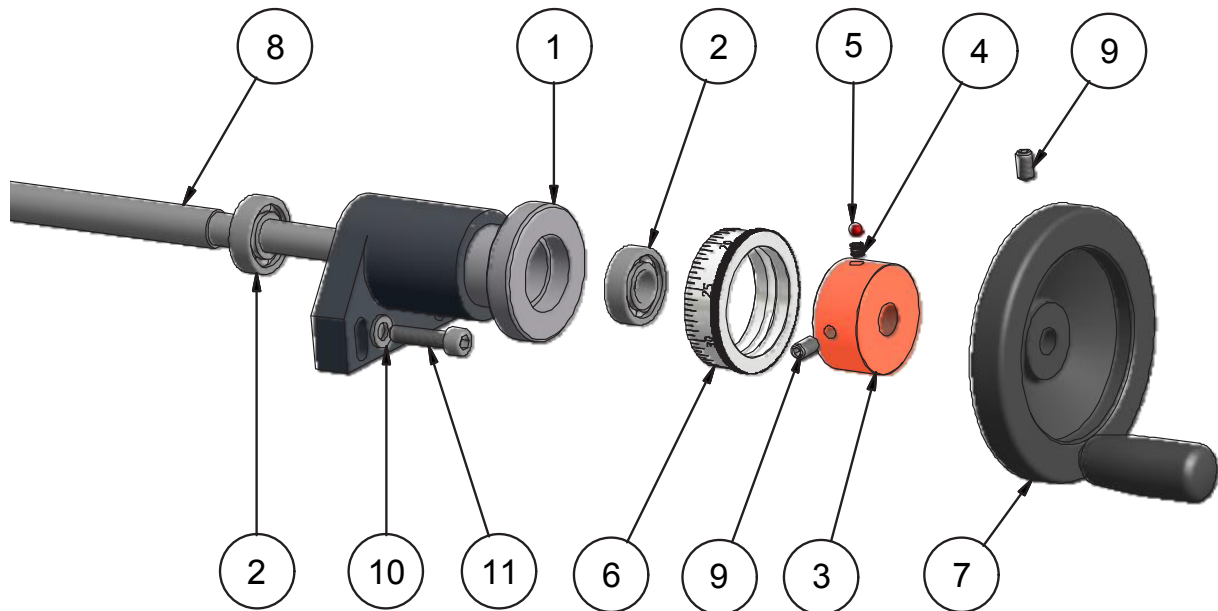

17. Drawings and legends

17.16 Spindle Y-axis with ball screw

17.16.1 F1200 – F1200 hs – F1210 – F1210 hs

Part no.	Items	Order number	Description
1	1	51401155-00011	Spindle bearing
2	2	51502112	Grooved ball bearing
3	1	51004040-0003	Adjusting ring
4	1	51502027-0001	Pressure spring
5	1	51502131	Steel ball
6	1	51006750-00012	Scale ring (100 intervals)
7	1	51507026-0001	Hand wheel
9	2	16091300006006	Threaded pin
10	2	16112500006001	Washer
11	2	16191200006025	Screw
			F1200 - F1200 hs
			F1210 - F1210 hs
8	1	51505211-0001	Spindle with spindle nut
			For transverse extension
8	1	51505211-0002	Spindle with spindle nut

17. Drawings and legends

17.16 Spindle Y-axis with ball screw

17.16.2 F1200-C – F1200-C hs – F1210-C – F1210-C hs
CC-F1200 – CC-F1200 hs – CC-F1210 – CC-F1210 hs

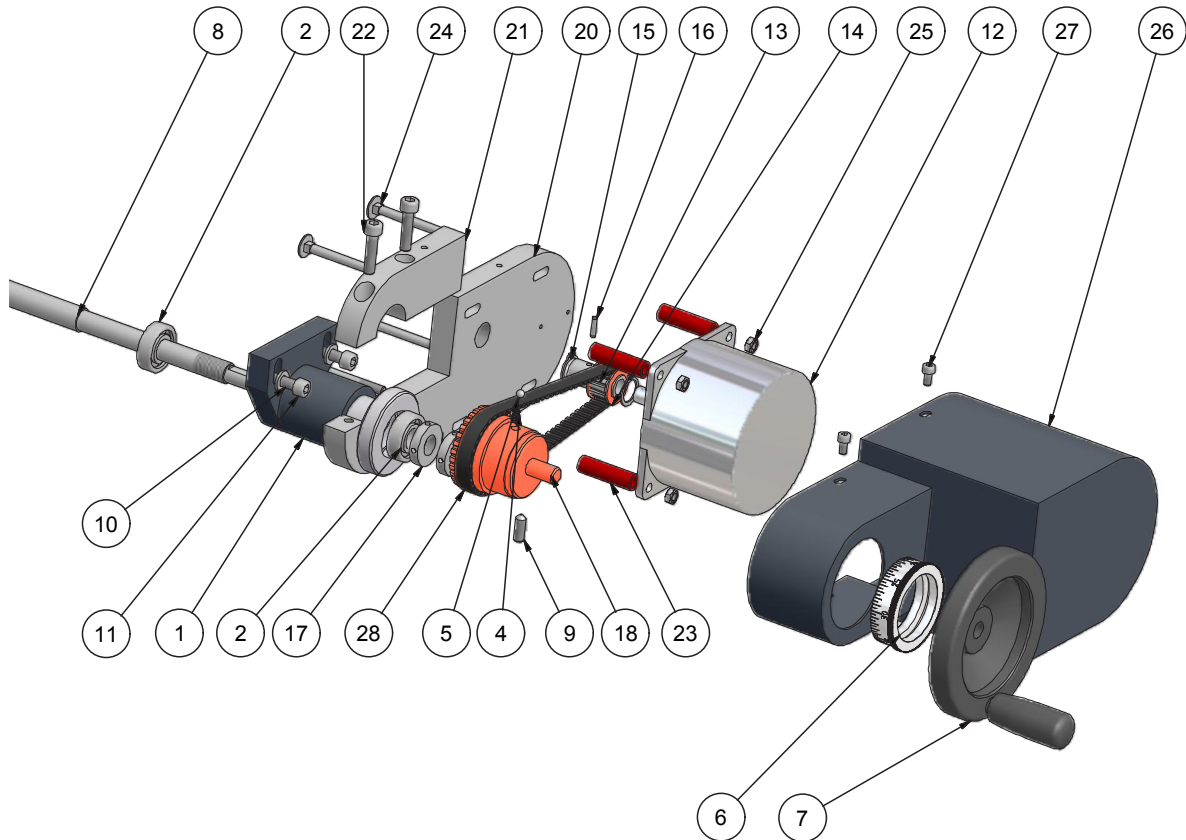

17. Drawings and legends

17.16 Spindle Y-axis with ball screw

17.16.2 F1200-C – F1200-C hs – F1210-C – F1210-C hs CC-F1200 – CC-F1200 hs – CC-F1210 – CC-F1210 hs

Part no.	Items	Order no.	Description
1	1	51401155-00011	Spindle bearing
2	2	51502112	Grooved ball bearing
4	1	51502027-0001	Pressure spring
5	1	51502131	Steel ball
6	1	51006750-00012	Scale ring (100 intervals)
7	1	51507027-0001	Hand wheel
9	1	16091300006010	Threaded pin
10	2	16112500006001	Washer
11	2	16191200006025	Screw
12	1	51500122	Stepper motor
13	1	51004020-0002	Belt disk
14	2	16000002214010	Adjusting washer
15	2	16047100014000	Securing ring
16	1	16073430003014	Spiral tensioning pin
18	1	51004050-0009	Gear belt pulley
20	1	51401422-0001	Motor holder
21	1	51401426-0001	Clamp to motor holder
22	2	16191200006030	Screw
23	4	51004010-0021	Spacer, stepper motor
24	4	16160300005060	Screw
25	4	16193400005000	Nut
26	1	51401501-0001	Cover hood for stepper motor
27	4	16191200004010	Screw
28	1	51502323	Gear belt
			F1200-C - F1200-C hs CC-F1200 – CC-F1200 hs F1210-C - F1210-C hs CC-F1210 – CC-F1210 hs
8	1	51505211-0001	Spindle with spindle nut
			For transverse extension
8	1	51505211-0002	Spindle with spindle nut

17. Drawings and legends

17.17 Limit switch for X-axis

17.17.1 F1200-C – F1200-C hs – F1210-C – F1210-C hs
 CC-F1200 – CC-F1200 hs – CC-F1210 – CC-F1210 hs

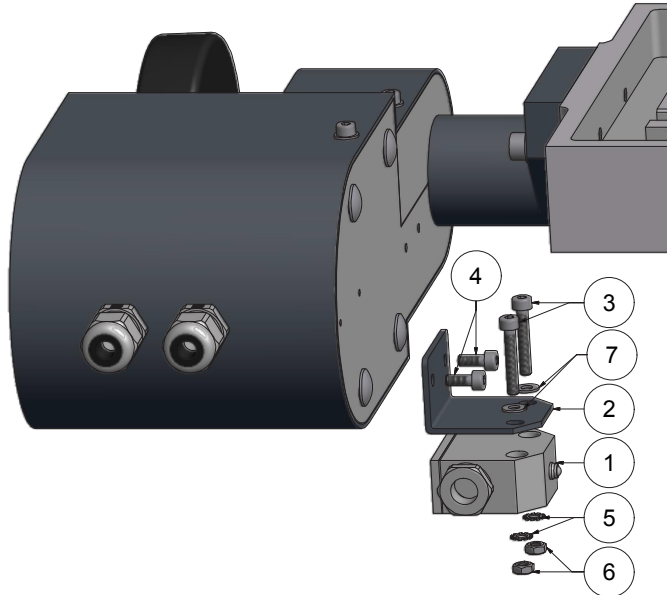

Part no.	Items	Order no.	Description
1	1	51500633-0001	Limit switch
2	1	51401151-0001	Mounting bracket
3	2	16191200004025	Screw
4	2	16191200004010	Screw
5	2	16167980004000	Fanned washer
6	2	16193400004000	Nut

17.18 Limit switch for Y-axis

17.18.1 F1200-C – F1200-C hs – F1210-C – F1210-C hs
 CC-F1200 – CC-F1200 hs – CC-F1210 – CC-F1210 hs

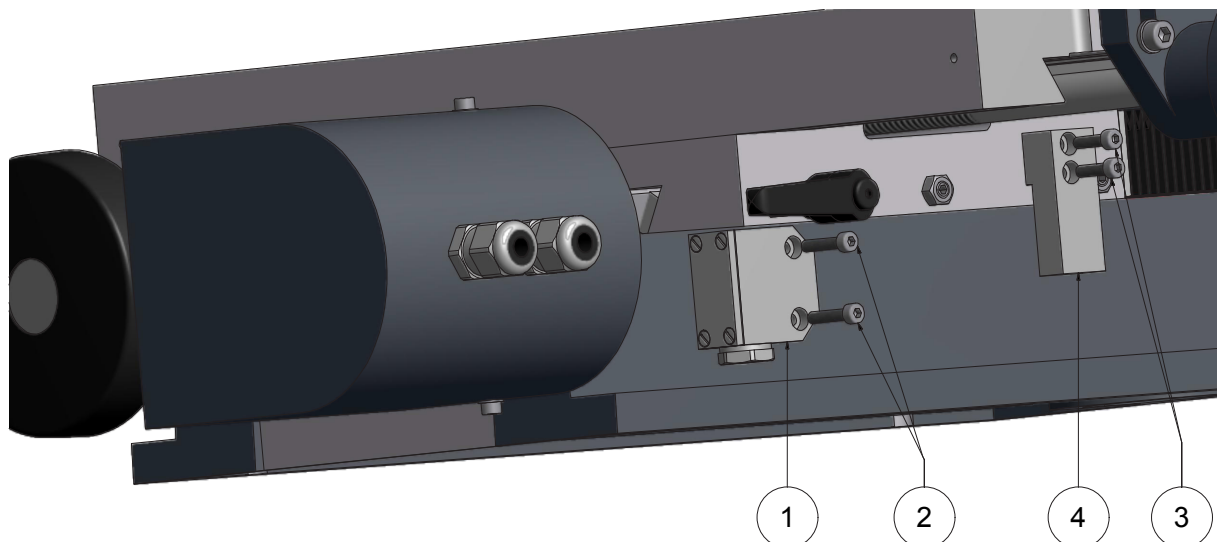

17. Drawings and legends

17.18 Limit switch for Y-axis

17.18.1 F1200-C – F1200-C hs – F1210-C – F1210-C hs
 CC-F1200 – CC-F1200 hs – CC-F1210 – CC-F1210 hs

Part no.	Items	Order no.	Description
1	1	51500633-0001	Limit switch
2	2	16191200004020	Screw
3	2	16191200004016	Screw
4	1	51006425-0002	Stop

17.19 Limit switch for Z-axis

17.19.1 F1200-C – F1200-C hs – F1210-C – F1210-C hs
 CC-F1200 – CC-F1200 hs – CC-F1210 – CC-F1210 hs

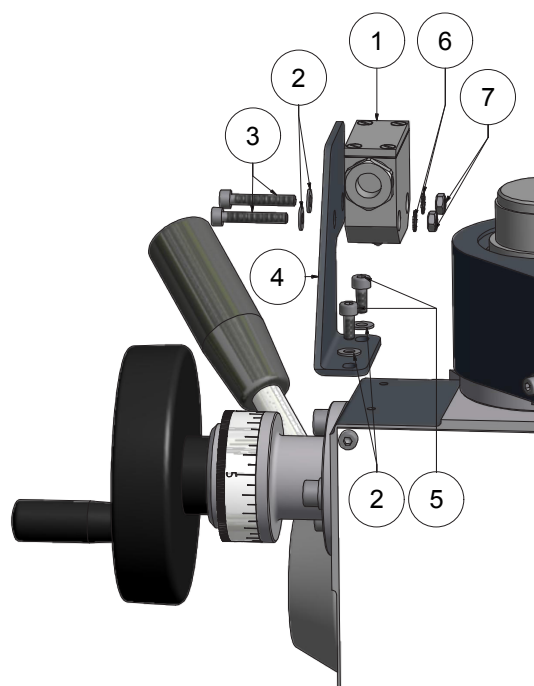

Part no.	Items	Order no.	Description
1	1	51500633-0001	Limit switch
2	2	16112500004000	Washer
3	2	16191200004025	Screw
4	1	51401548-0001	Mounting bracket
5	2	16191200004010	Screw
6	2	16167980004000	Fanned washer
7	2	16193400004000	Nut

17. Drawings and legends

17.20 Machine control panel for 1.4 kW motor

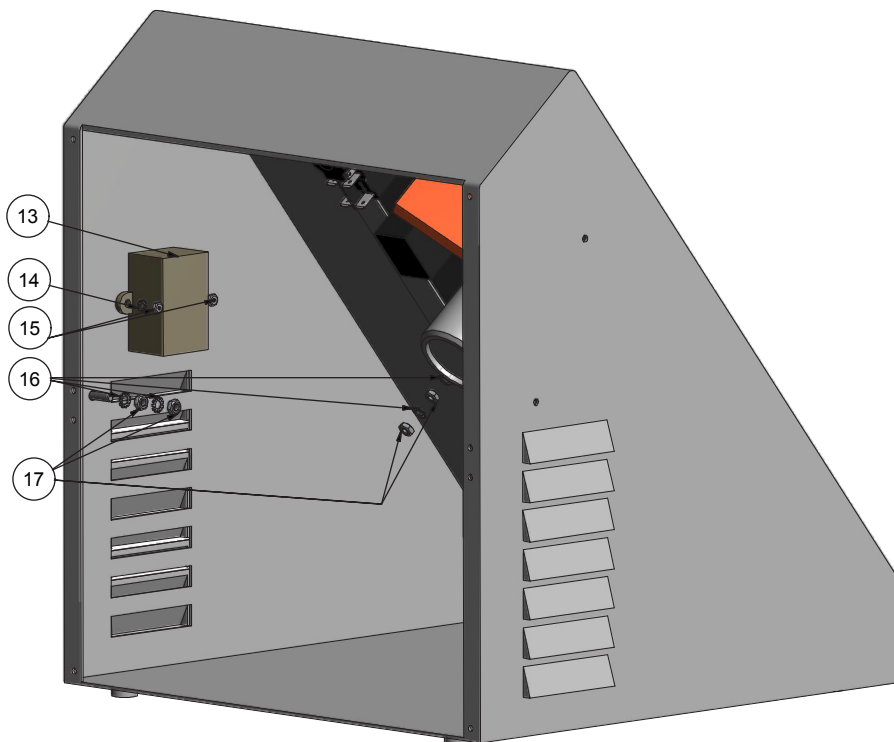
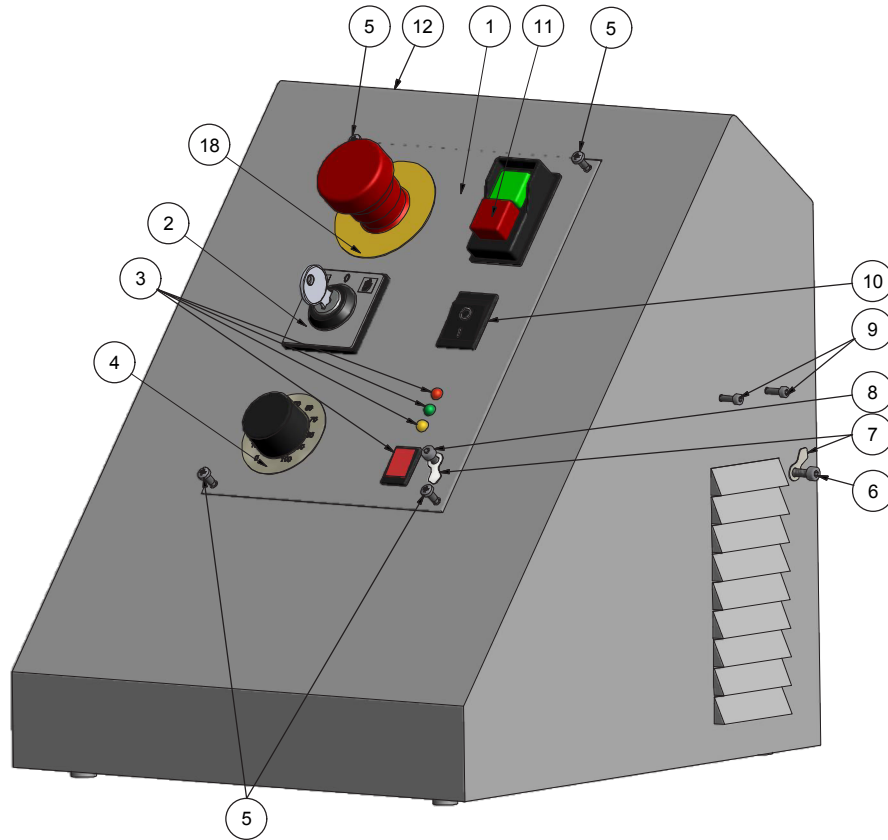

17. Drawings and legends

17.20 Machine control panel for 1.4 kW motor

Part no.	Items	Order no.	Description
1	1	51401540-0001	Switch cover
2	1	51500600	Switch for operating modes
3			LEDs with switch (contained in controller package)
4	1	51500807-0002	Potentiometer with cable and connector
4.1	1	51500807-00021	Potentiometer. complete
5	4	16179810003095	Screw
6	1	16191200004025	Screw
7	2	51501304	Symbol for earthed connection
8	1	16191200004012	Screw
9	2	16191200003010	Screw
10	1	51500601	Switch
11	1	51500606-0001	On-Off switch
12	1	51401509-0001	Controller housing
13	1	51500800-0001	Noise filter
14	2	16167980003000	Fanned washer
15	2	16193400003000	Nut
16	4	16167980004000	Fanned washer
17	4	16193400004000	Nut
18	1	51500624-0001	Emergency off switch, complete

17. Drawings and legends

17.20 Machine control panel for 1.4 kW motor

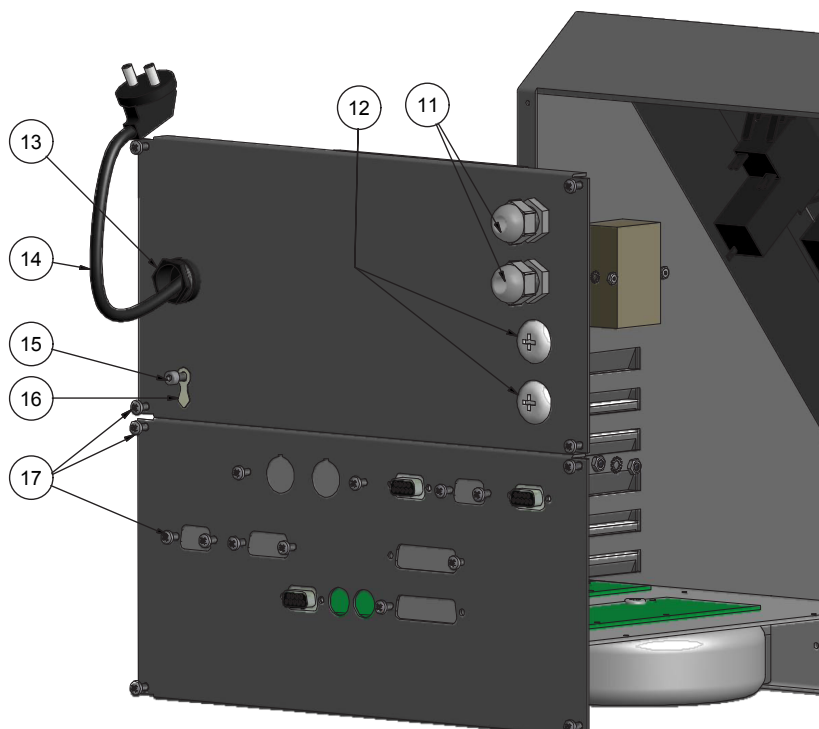
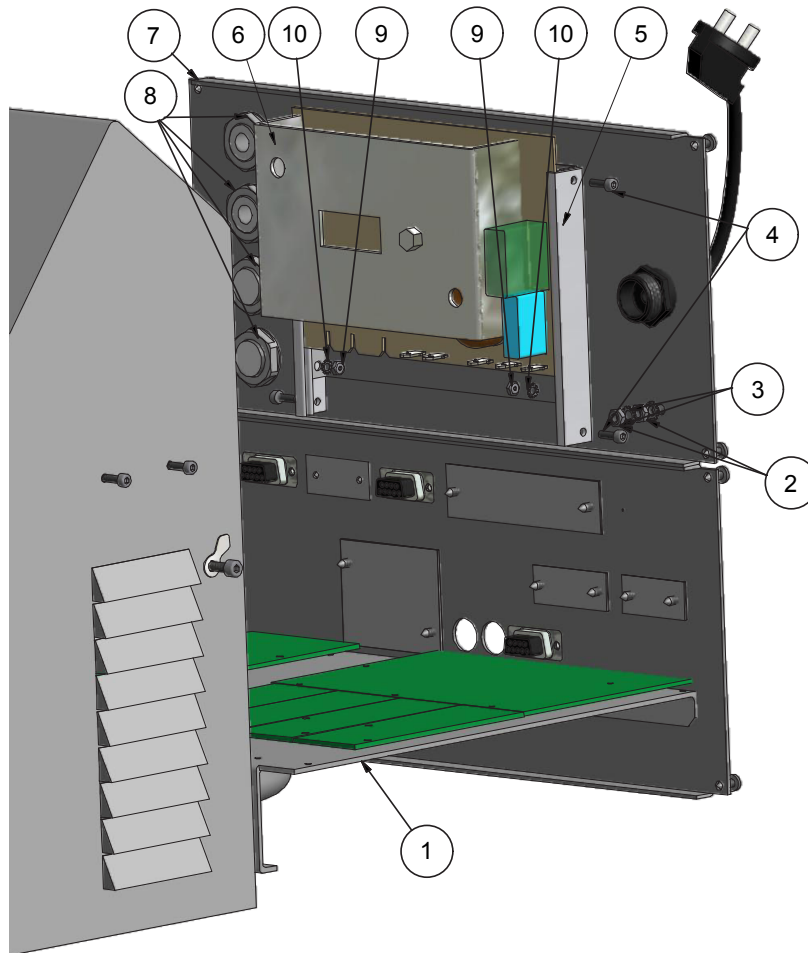

17. Drawings and legends

17.20 Machine control panel for 1.4 kW motor

Part no.	Items	Order no.	Description
1	1	1152105	Controller board for basic milling
	1	1152110	Controller board for professional milling
2	2	16193400004000	Nut
3	2	16167980004000	Fanned washer
4	4	16191200003010	Screw
5	2	51500401-0001	Guide rails
6	1	51501402	Control board
7	1	51401528-0001	Lid, top
8	4	51501505	Counter nut
9	4	16193400003000	Nut
10	4	16167980003000	Fanned washer
11	2	51501533	Cable screw
12	2	51501523	Closure screw
13	1	51501531	Strain relief
14	1	51500920-0003	Mains cable
15	1	16191200004012	Screw
16	1	51501304	Symbol for earthed connection
17	20	16179810003095	Screw

17. Drawings and legends

17.21 Machine control panel for 2.0 kW motor

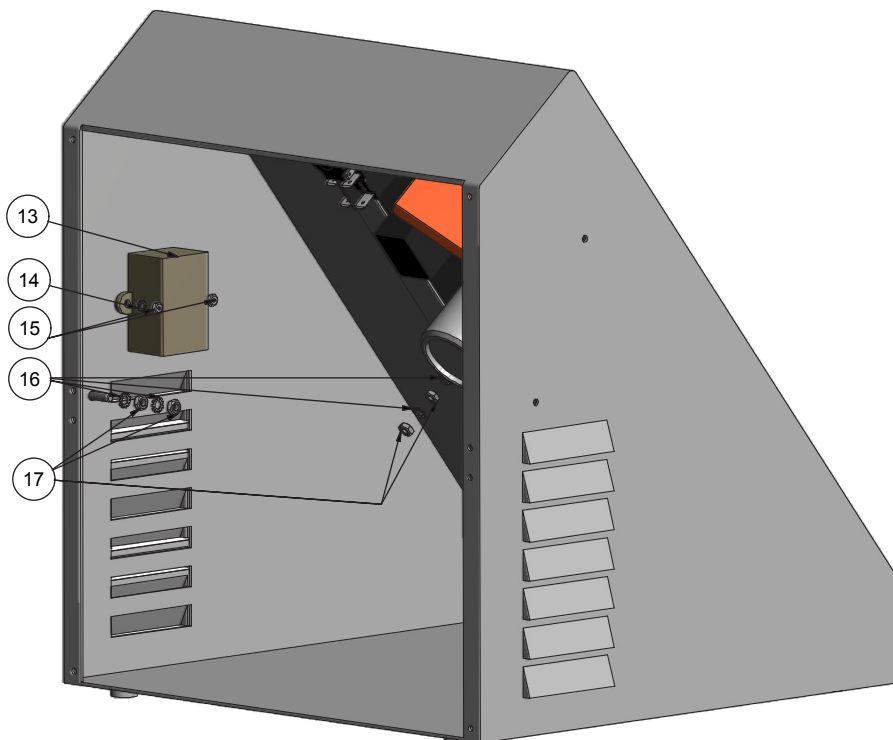
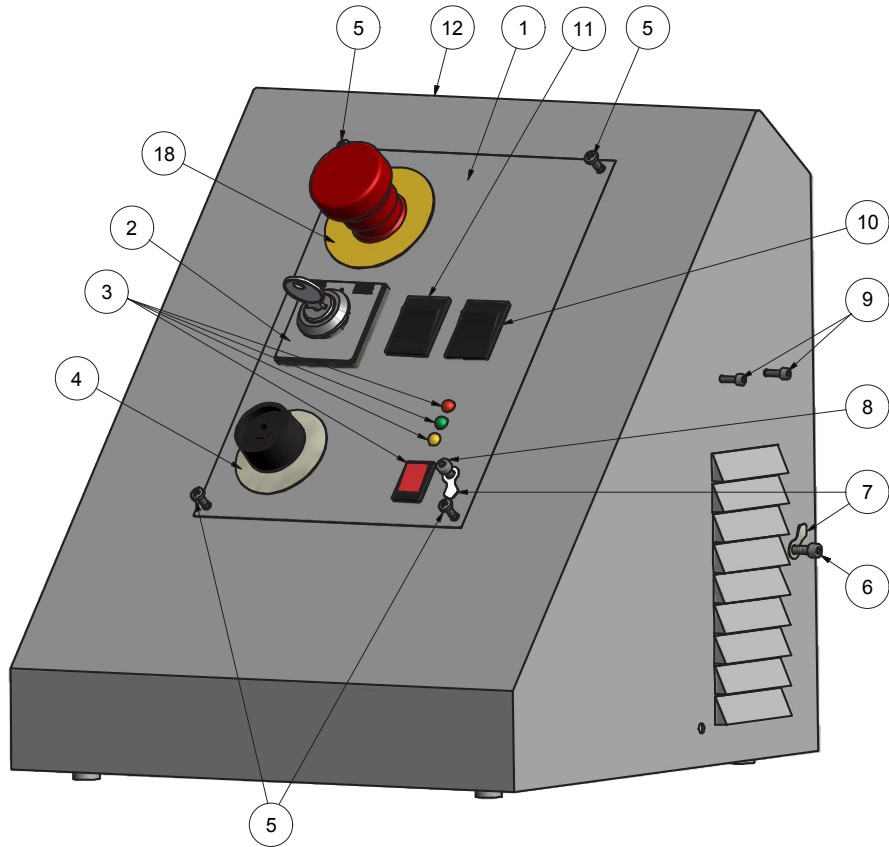

17. Drawings and legends

17.21 Machine control panel for 2.0 kW motor

Part no.	Items	Order no.	Description
1	1	51401539-0001	Switch cover
2	1	51500600	Switch for operating modes
3			LEDs with switch (contained in controller package)
4	1	51500801-0001	Potentiometer
5	4	16179810003095	Screw
6	1	16191200004025	Screw
7	2	51501304	Symbol for earthed connection
8	1	16191200004012	Screw
9	2	16191200003010	Screw
10	1	51500601	Switch
11	1	51500602	Switch
12	1	51401509-0001	Controller housing
13	1	51500800-0001	Noise filter
14	2	16167980003000	Fanned washer
15	2	16193400003000	Nut
16	4	16167980004000	Fanned washer
17	4	16193400004000	Nut
18	1	51500624-0001	Emergency off switch, complete

17. Drawings and legends

17.21 Machine control panel for 2.0 kW motor

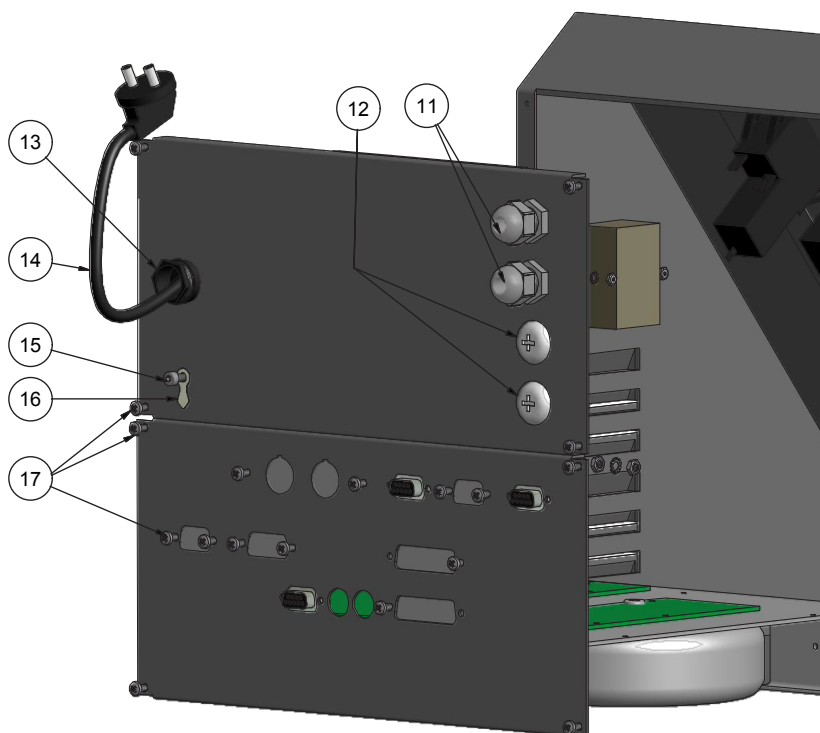
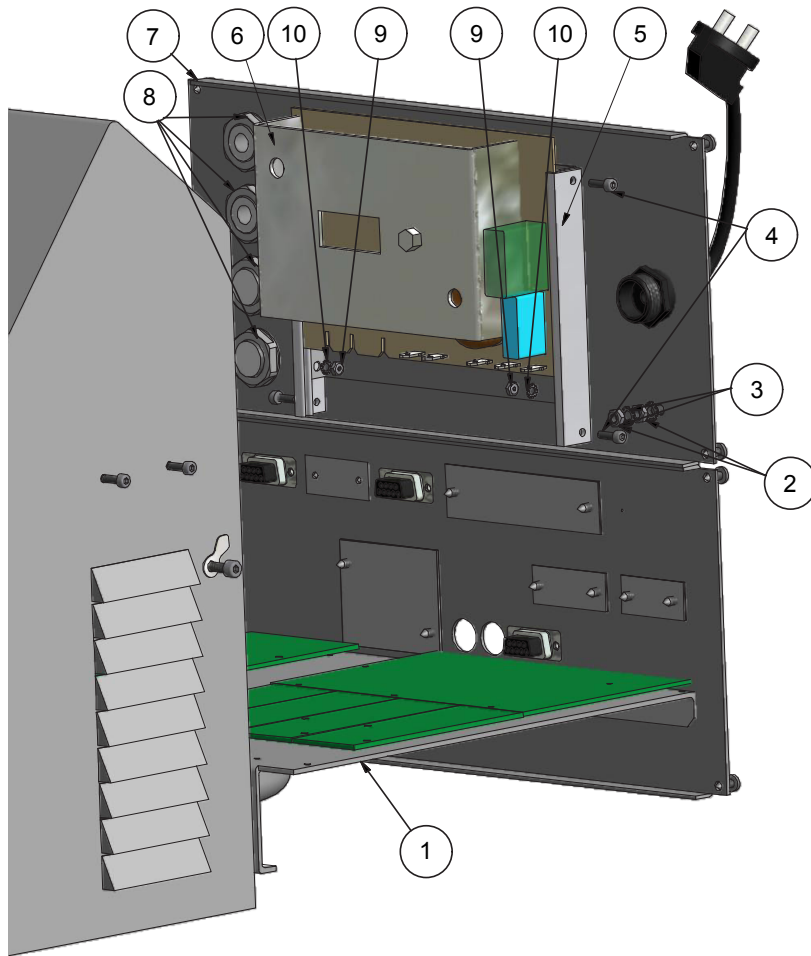

17. Drawings and legends

17.21 Machine control panel for 2.0 kW motor

Part no.	Items	Order no.	Description
1	1	1152105	Controller board for basic milling
	1	1152110	Controller board for professional milling
2	2	16193400004000	Nut
3	2	16167980004000	Fanned washer
7	1	51401528-0001	Lid, top
8	4	51501505	Counter nut
11	2	51501533	Cable screw
12	2	51501523	Closure screw
13	1	51501531	Strain relief
14	1	51500920-0003	Mains cable
15	1	16191200004012	Screw
16	1	51501304	Symbol for earthed connection
17	20	16179810003095	Screw

17. Drawings and legends

17.22 Support arm for machine control panel

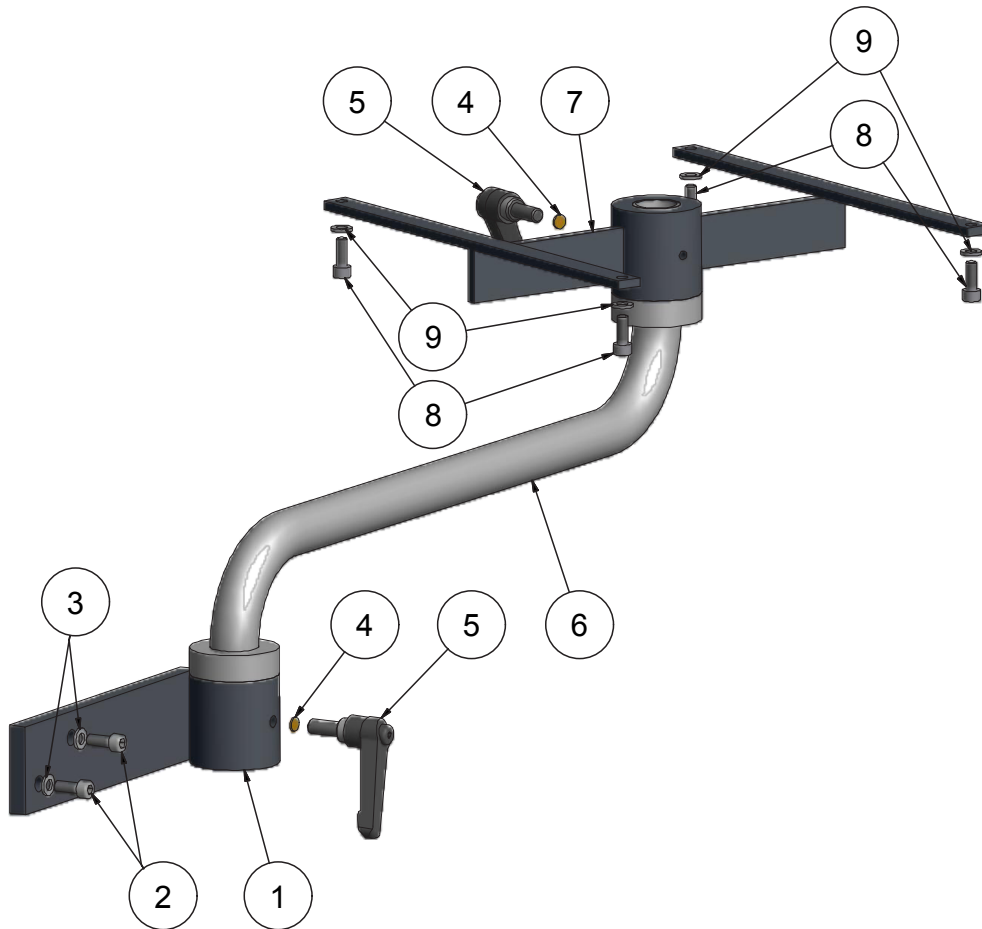

17. Drawings and legends

17.22 Support arm for machine control panel

Part no.	Items	Order no.	Description
4	2	51007250-0001	Push piece
5	2	51507029	Clamping lever
6	1	51401316-0001	Console arm
7	1	51001016-00031	Holder for controller housing
8	4	16191200006016	Screw
9	4	16112500006001	Washer
Without machine safety cabin			
1	1	51002051-00011	Holder for arm
2	2	16191200008020	Screw
3	2	16112500008001	Washer
In connection with machine safety cabin			
1	1	51002130-00031	Holder for arm
2	2	16191200010030	Screw
3	2	16112500010000	Washer

17. Drawings and legends

17.23 Industrial monitor and membrane keyboard

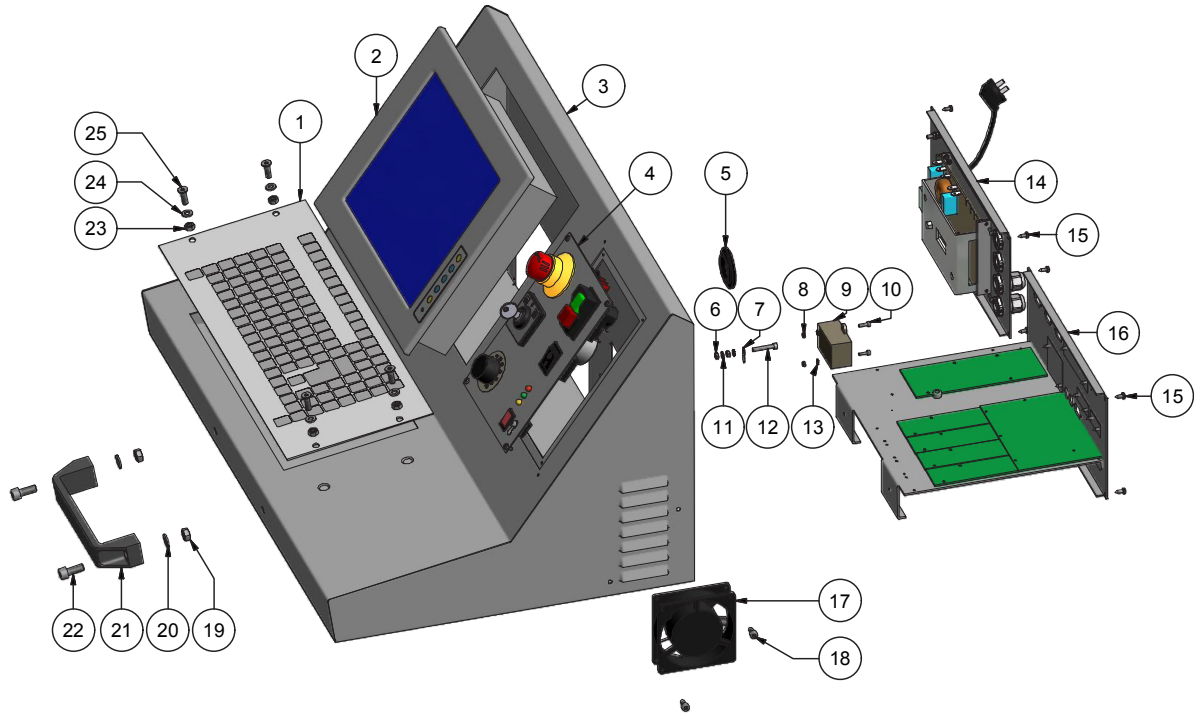

17. Drawings and legends

17.23 Industrial monitor and membrane keyboard

Part no.	Items	Order no.	Description
1	1	51505031	19" Installation-folio keyboard
2	1	51505030	TFT-flat panel monitor
	1	51505043	Mounting kit for TFT-flat panel monitor
3	1	51401537-0001	Controller housing for industrial monitor
4	1		Switch cover
5	1	51508322-0001	Cable bushing
6	2	16193400004000	Nut
7	1	51501304	Symbol for earthed connection
8	2	16193400003000	Nut
9	1	51500800	Noise filter
10	2	16191200003010	Screw
11	2	16167980004000	Fanned washer
12	1	16191200004025	Screw
13	2	16167980003000	Fanned washer
14	1		Cover
15	8	16179810003095	Screw
16	1	1152105	Controller board nccad basic
		1152110	Controller board nccad professional
17	1	51500121	Fan
18	2	16191200005010	Screw
19	2	16193400008000	Nut
20	2	16112500008001	Washer
21	1	51507006	Handle
22	2	16191200008020	Screw
23	4	16193400006000	Nut
24	4	16112500006001	Washer
25	4	16179910006020	Screw

17. Drawings and legends

17.23 Industrial monitor and membrane keyboard

17.23.1 Industrial monitor and membrane keyboard for 1.4 kW motor

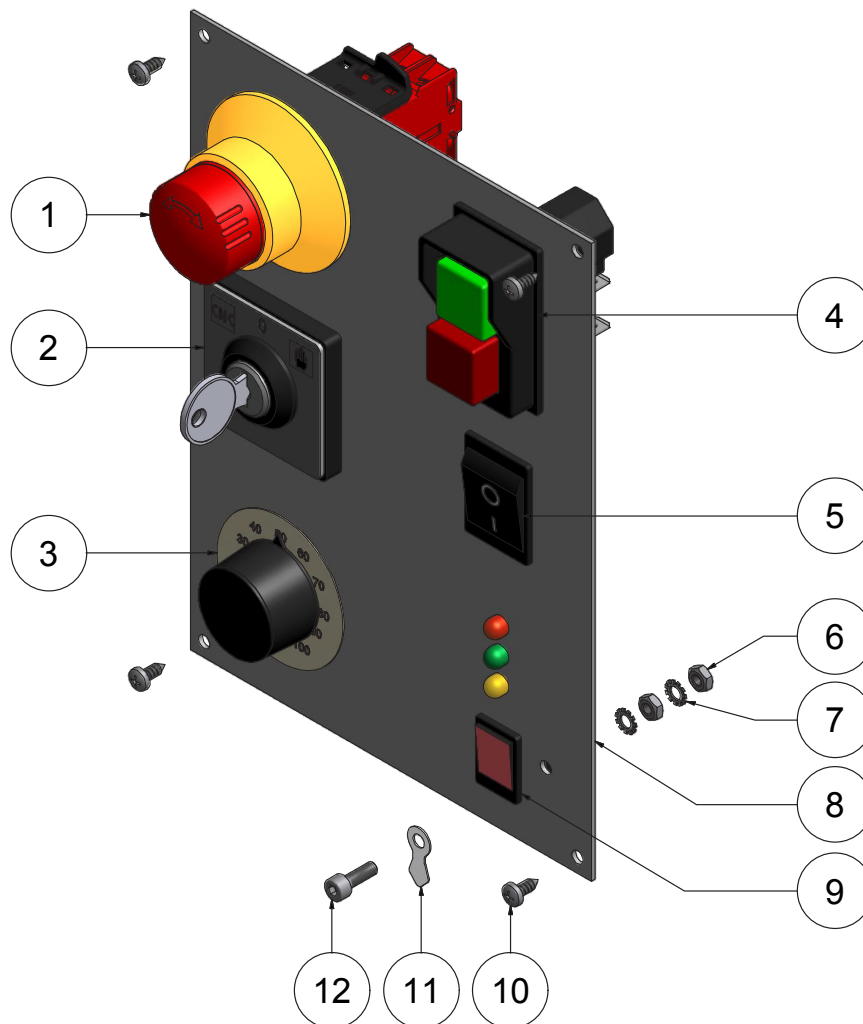

Part no.	Items	Order no.	Description
1	1	51500624-0001	Emergency off switch complete
2	1	51500600	Switch for operating modes
3	1	51500807-0002	Potentiometer with cable and connector
3.1	1	51500807-00021	Potentiometer complete
4	1	51500606-0001	On-Off switch
5	1	51500601	Switch
6	2	16193400004000	Nut
7	2	16167980004000	Fanned washer
8	1	51401540-0001	Switch cover
9			LEDs with switch (contained in controller package)
10	4	16179810003095	Screw
11	1	51501304	Symbol for earthed connection
12	1	16191200004012	Screw

17. Drawings and legends

17.23 Industrial monitor and membrane keyboard

17.23.1 Industrial monitor and membrane keyboard for 1.4 kW motor

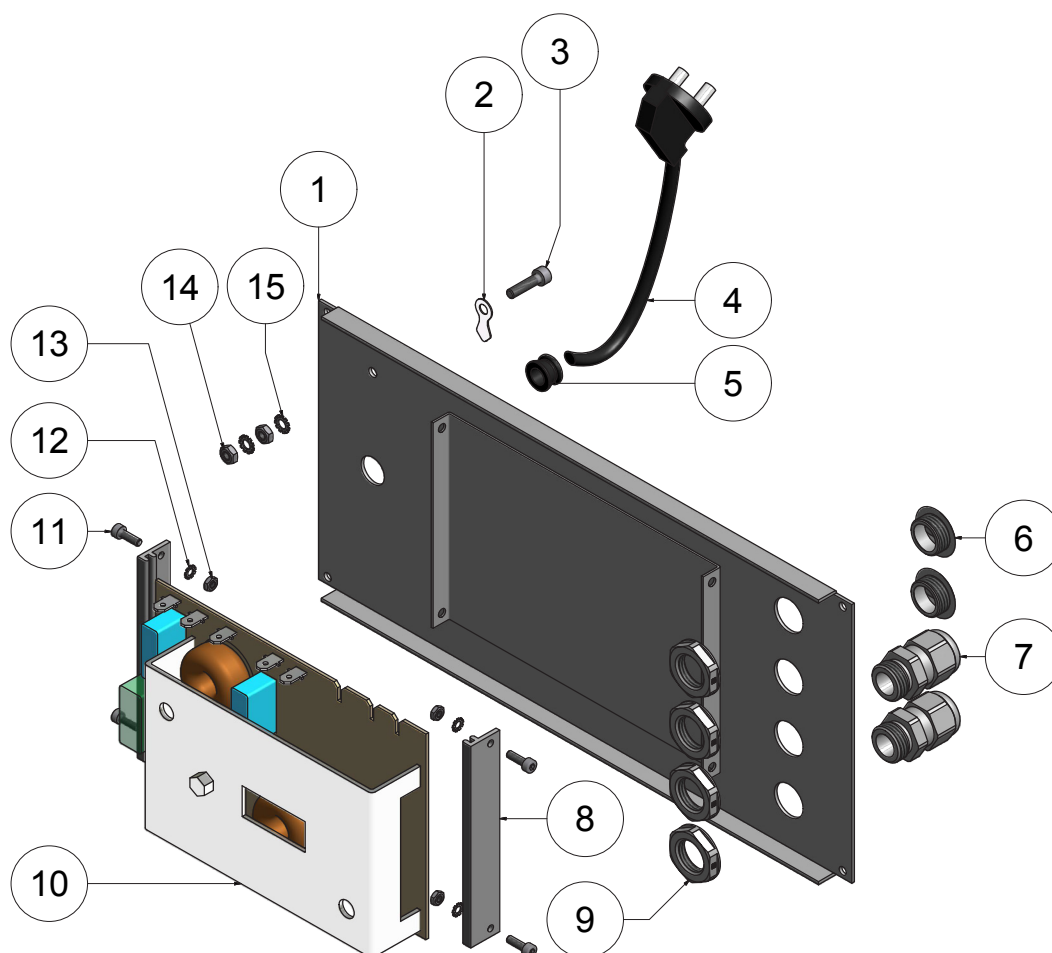

Part no.	Items	Order no.	Description
1	1	51401528-0001	Cover
2	1	51501304	Symbol for earthed connection
3	1	16191200004012	Screw
4	1	51500920-0003	Mains cable
5	1	51501531	Strain relief
6	2	51501523	Closure screw
7	2	51501533	Cable screw
8	2	51500401-0001	Guide rails
9	4	51501505	Counter nut
10	1	51501402	Control board
11	4	16191200003010	Screw
12	4	16167980003000	Fanned washer
13	4	16193400003000	Nut
14	2	16193400004000	Nut
15	2	16167980004000	Fanned washer

17. Drawings and legends

17.23 Industrial monitor and membrane keyboard

17.23.2 Industrial monitor and membrane keyboard for 2.0 kW motor

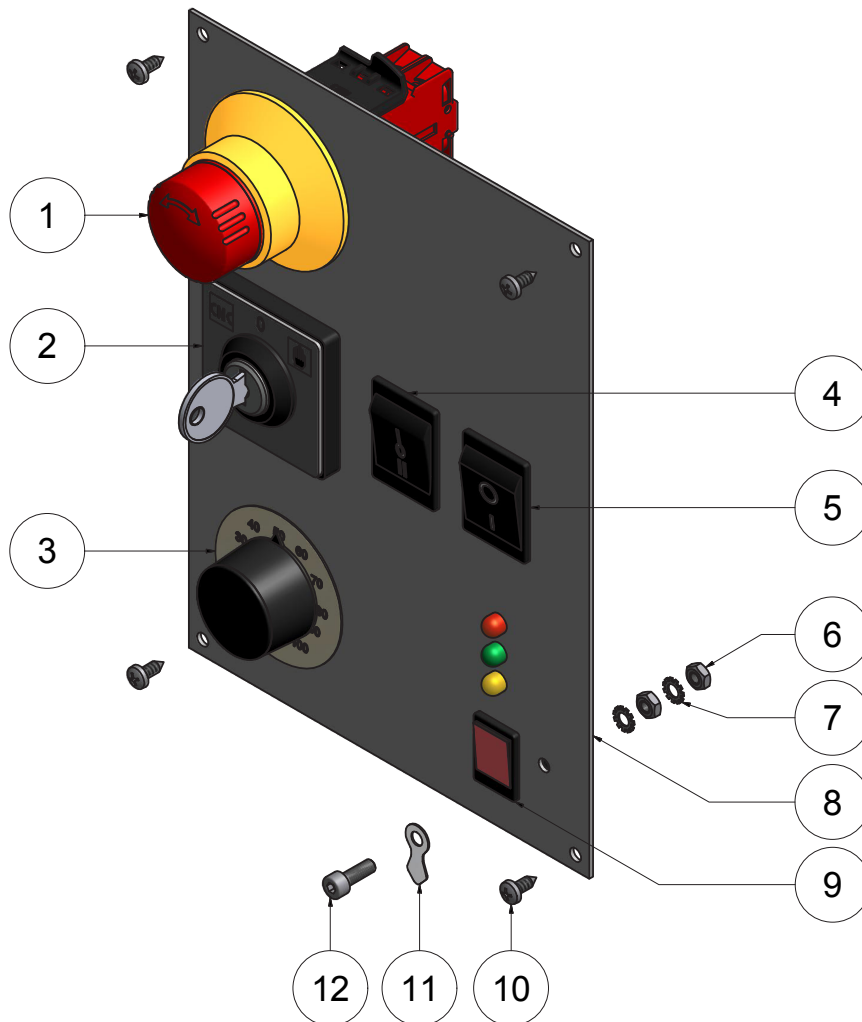

Part no.	Items	Order no.	Description
1	1	51500624-0001	Emergency off switch complete
2	1	51500600	Switch for operating modes
3	1	51500801-00011	Potentiometer
4	1	51500602	Switch
5	1	51500601	Switch
6	2	16193400004000	Nut
7	2	16167980004000	Fanned washer
8	1	51401539-0001	Switch cover
9			LEDs with switch (contained in controller package)
10	4	16179810003095	Screw
11	1	51501304	Symbol for earthed connection
12	1	16191200004012	Screw

17. Drawings and legends

17.23 Industrial monitor and membrane keyboard

17.23.2 Industrial monitor and membrane keyboard for 2.0 kW motor

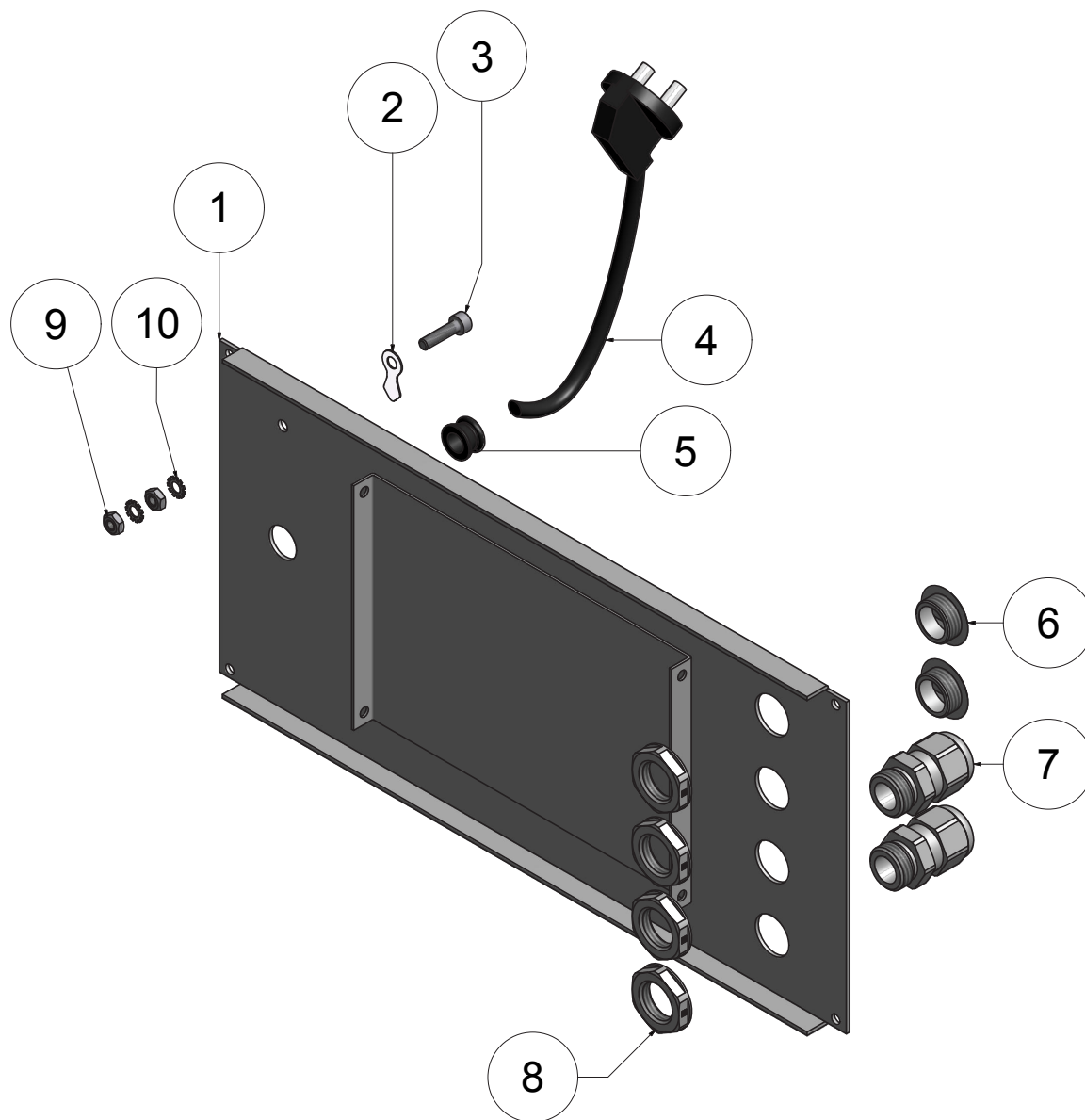

Part no.	Items	Order no.	Description
1	1	51401528-0001	Cover
2	1	51501304	Symbol for earthed connection
3	1	16191200004012	Screw
4	1	51500920-0003	Mains cable
5	1	51501531	Strain relief
6	2	51501523	Closure screw
7	2	51501533	Cable screw
8	4	51501505	Counter nut
9	2	16193400004000	Nut
10	2	16167980004000	Fanned washer

17. Drawings and legends

17.24 Support arm for industrial monitor and membrane keyboard

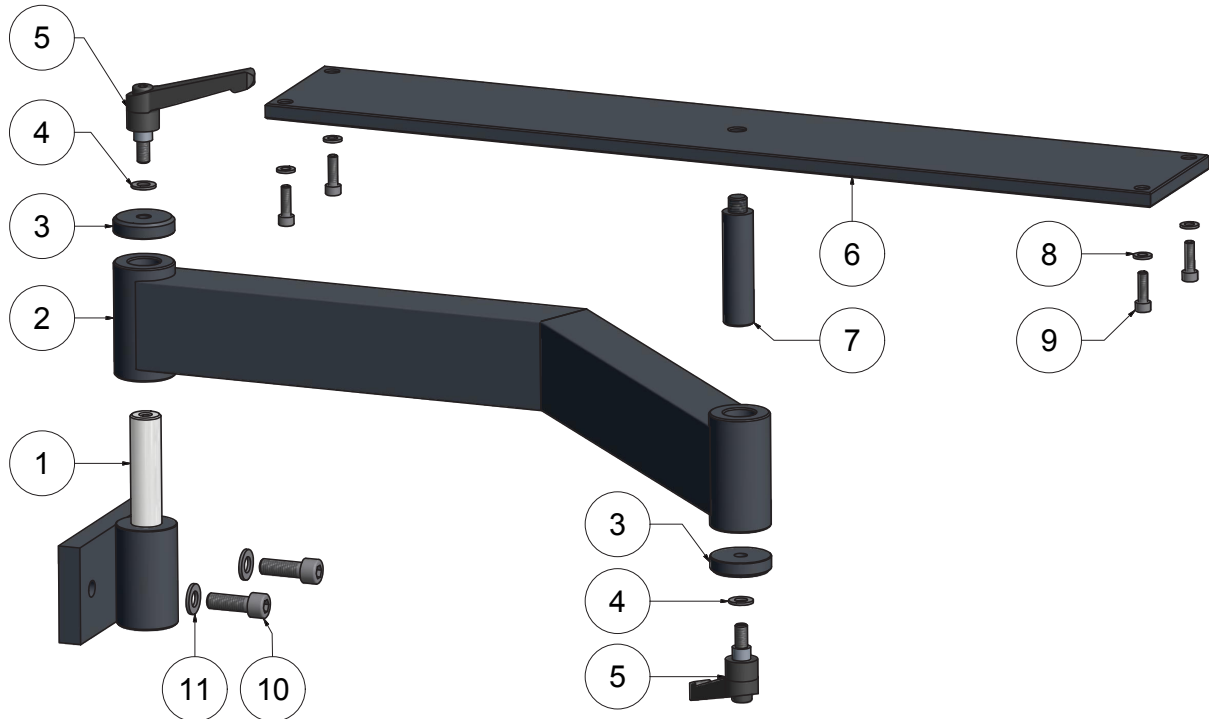

Part no.	Items	Order no.	Description
1	1	51002130-00032	Holder for arm
2	1	51002416-00011	Console arm
3	2	51004040-0006	Washer
4	2	16112500008001	Washer
5	2	51507031-0003	Clamping lever
6	1	51002100-0001	Retaining plate for industrial monitor
7	1	51004020-0013	Bolt
8	4	16112500006001	Washer
9	4	16191200006020	Screw
10	2	16191200010030	Screw
11	2	16112500010000	Washer

18. Circuit diagram

18.1 for 1.4 kW motor

This document shows all the equipment for the electrical set-up including connection to the power supply network.

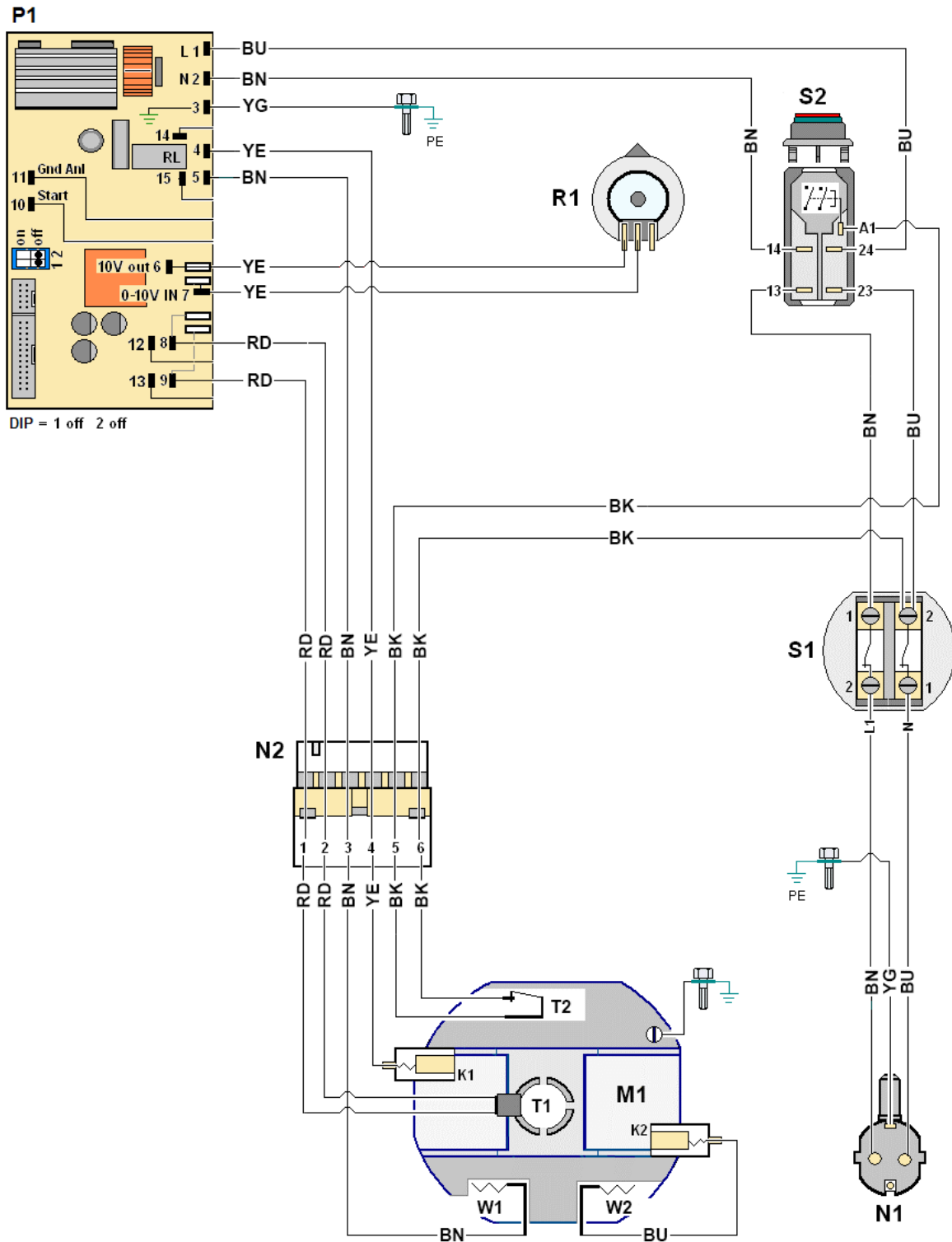

see legend for circuit diagrams 18.9

18. Circuit diagram

18.2 for 1.4 kW motor and machine safety cabin

This document shows all the equipment for the electrical set-up including connection to the power supply network.

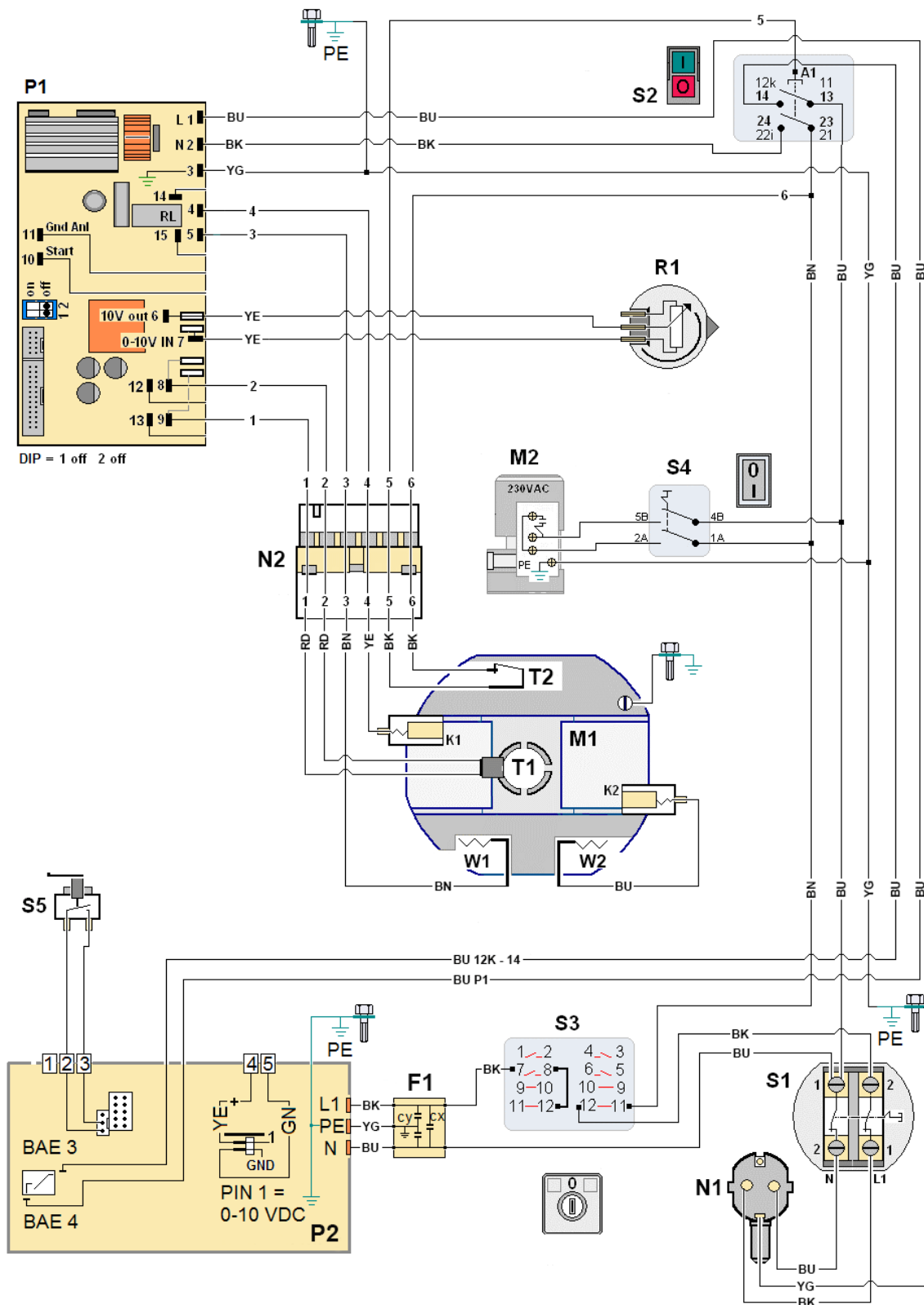

see legend for circuit diagrams 18.9

18. Circuit diagram

18.3 Industrial monitor and membrane keyboard for 1.4 kW motor

This document shows all the equipment for the electrical set-up including connection to the power supply network.

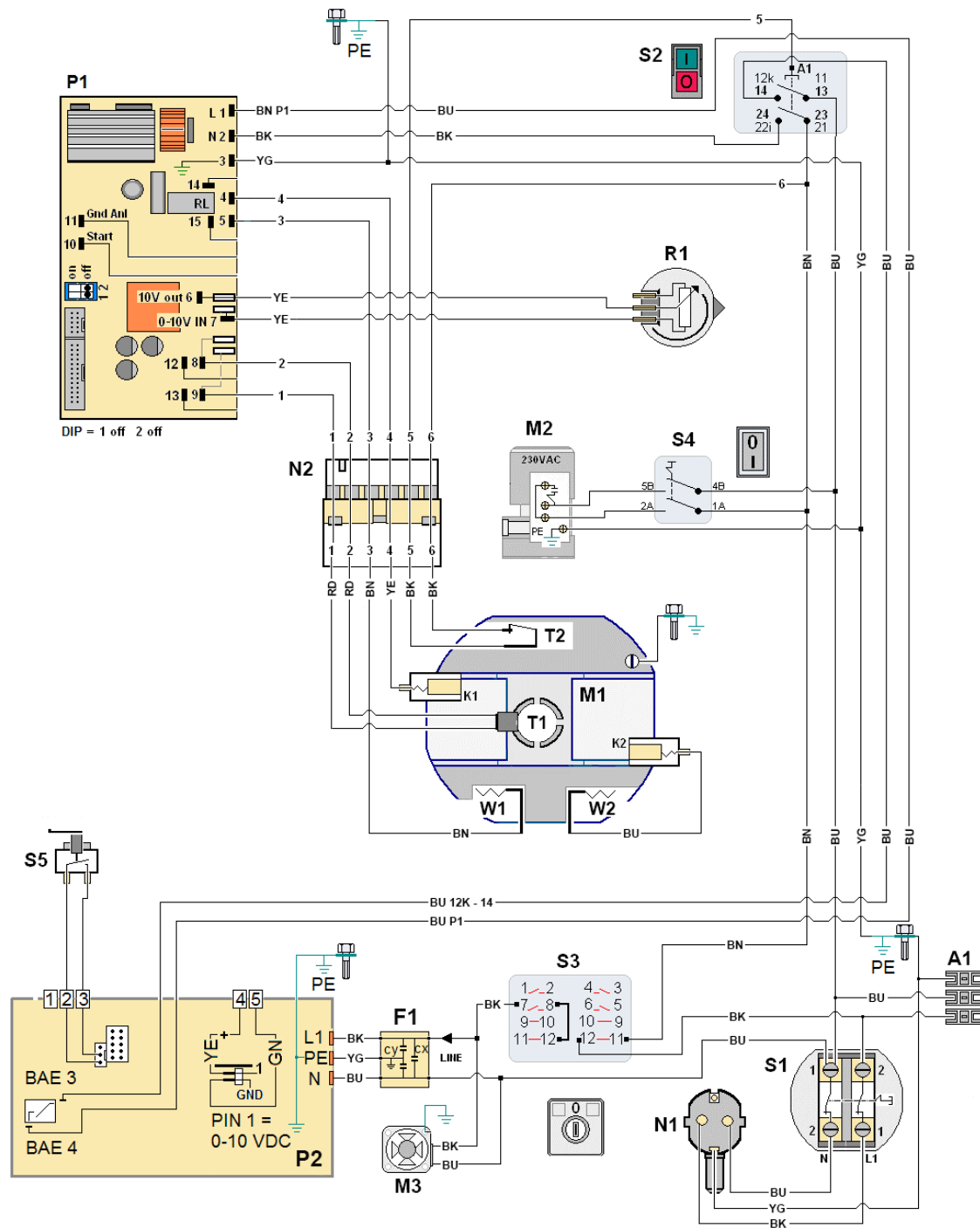

see legend for circuit diagrams 18.9

18. Circuit diagram

18.4 for 2.0 kW motor

This document shows all the equipment for the electrical set-up including connection to the power supply network.

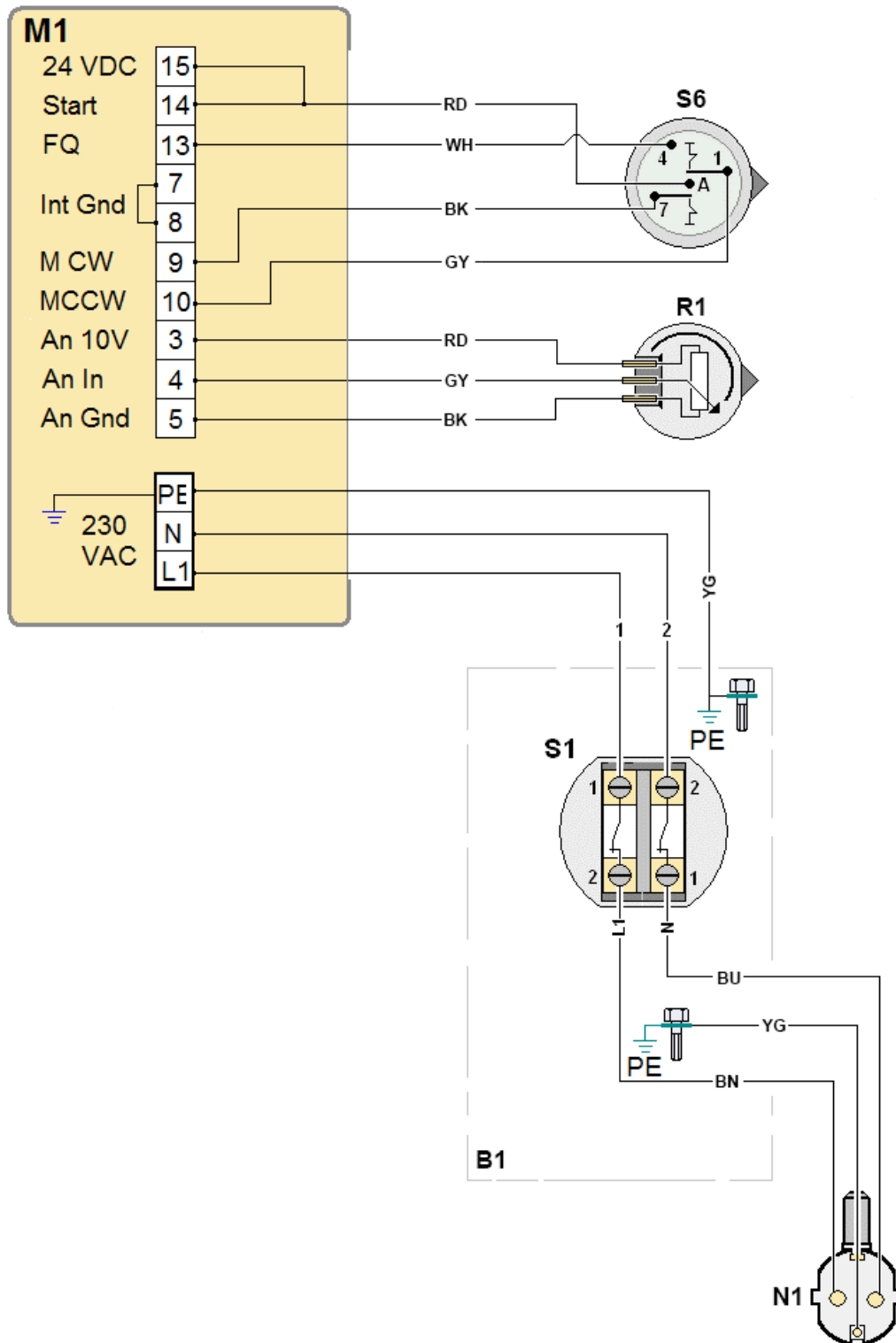

see legend for circuit diagrams 18.9

18. Circuit diagram

18.6 Industrial monitor and membrane keyboard for 2.0 kW motor

This document shows all the equipment for the electrical set-up including connection to the power supply network.

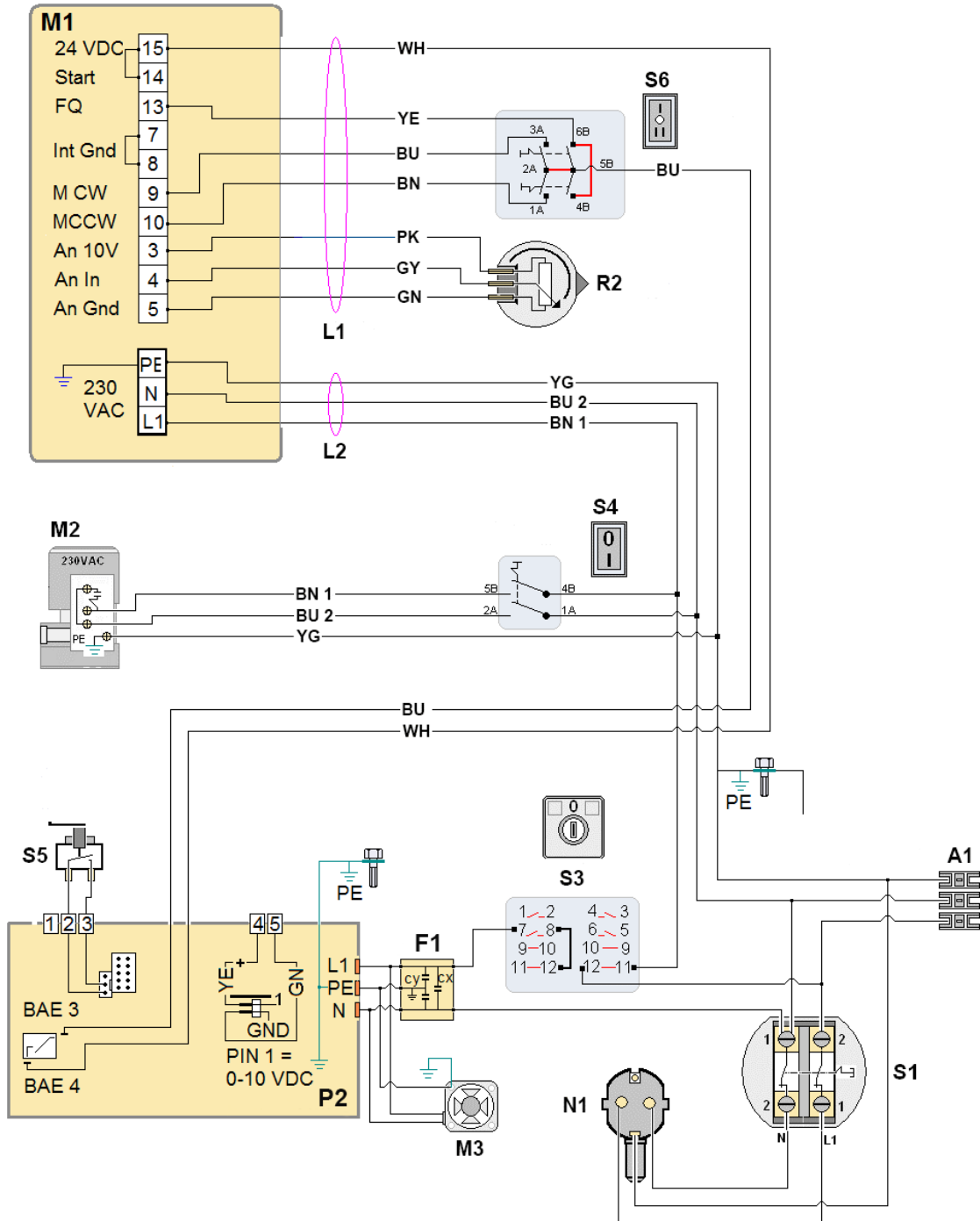

see legend for circuit diagrams 18.9

18. Circuit diagram

18.7 Stepper motor with limit switch

This document shows all the equipment for the electrical set-up including connection to the power supply network.

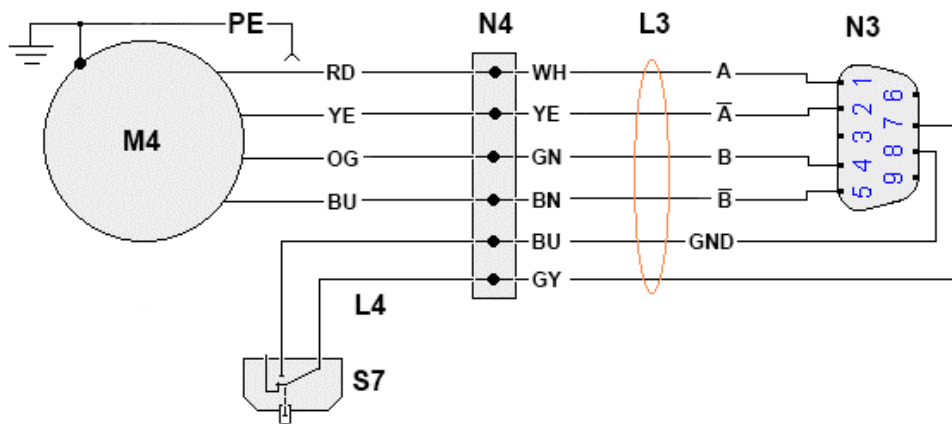

Direction of rotation - change green with brown
 see legend for circuit diagrams 18.9

18.8 NC-rotary table

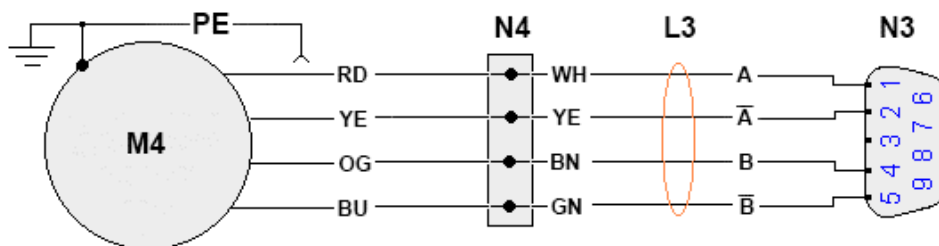

Direction of rotation - change green with brown
 see legend for circuit diagrams 18.9

18. Circuit diagram

18.9 Legend for circuit diagrams

Color-abbreviation to IEC 60757

BK	black	PK	pink
BN	brown	RD	red
BU	blue	WH	white
GN	green	YE	yellow
GY	gray	YG	green/yellow
OG	orange		

A1	Connector for industrial monitor
B1	Milling head hood
F1	Interference suppressor filter
K1	Carbon brush
K2	Carbon brush
L1	7- pin cable with shielding 0,34mm ²
L2	3- pin cable without shielding 1mm ²
L3	6-pin cable with shielding
L4	2- pin cable with shielding
M1	Main spindle motor
M2	Coolant pump
M3	Fan for industrial monitor
M4	Axis motor 3H8221-624/6A
N1	Mains power plug
N2	Motor connector
N3	9-pin connector
N4	Terminal board
P1	Motor control board
P2	CNC control board
PE	Protection against electric shock
R1	220 K Ω Potentiometer spindle revolutions
R2	10 K Ω Potentiometer spindle revolutions
S1	EMERGENCY OFF
S2	Main switch with low voltage trigger
S3	Mode selection switch
S4	Coolant switch
S5	Limit switch, machine safety cabin
S6	Direction change switch, spindle
S7	Limit switch
T1	Speedometer
T2	Temperature sensor
W1	Coil 1
W2	Coil 2

19. Coolant unit (optional)

19.1 Setting up the coolant unit

When mounting the coolant unit to a WABECO machine base cabinet, the appropriate bores are already present. The machine base cabinet ensures a safe base for the milling machine or coolant unit.

If the coolant unit is secured to another suitable surface, the two through holes must be bored into the surface by the client. For the positions of the two fixture threaded sockets (thread M8) of the coolant unit, see diagram. The diameter of the through holes in the surface must be at least 9 mm

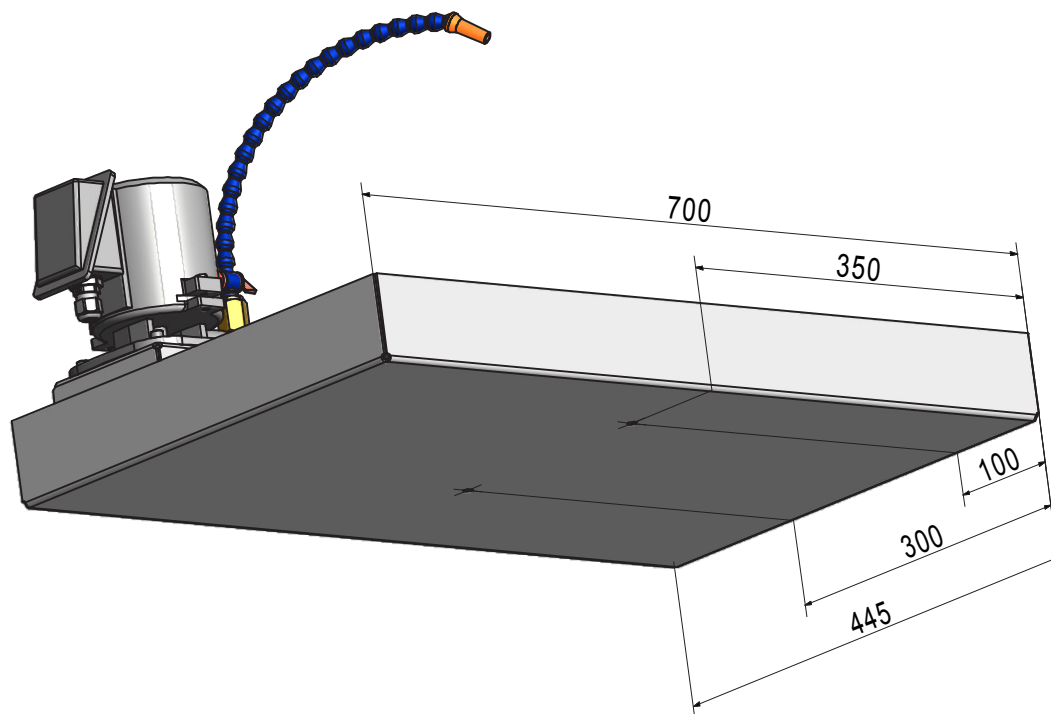

19.2 Mounting of the coolant unit to the machine base cabinet (optional)

- The coolant unit (2) is positioned, as shown, on the machine base cabinet (1).
- The screws and washers required for assembly are included in the scope of delivery.

To screw the coolant unit to the machine base cabinet

proceed as follows:

1. Combine each screw with a washer.
2. Open the door or the machine base cabinet.
3. Push the screws from below, through the bored holes in the machine base cabinet, into the fixture threaded sockets and tighten using an Allen key of size 6.

19. Coolant unit (optional)

19.2 Mounting of the coolant unit to the machine base cabinet (optional)

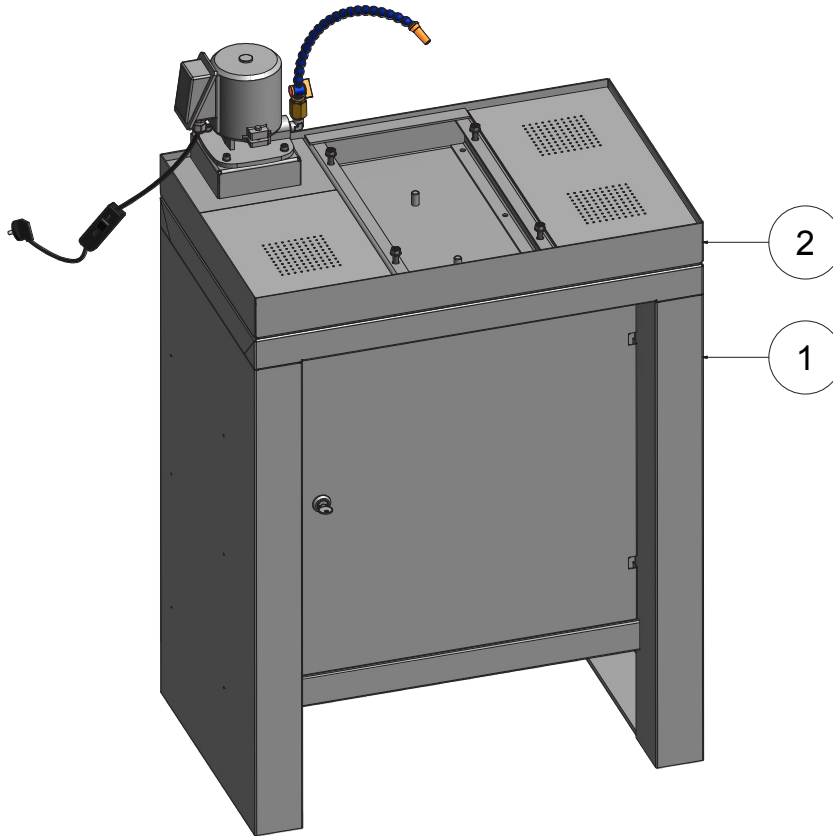

19.3 Mounting of the coolant return plate (optional)

The coolant return plate (2) collects dripping coolant from the workbench and returns it back to the coolant unit.

To mount, proceed as follows:

1. Fit the groove (X) to the protrusion (Y) of the coolant unit (1).

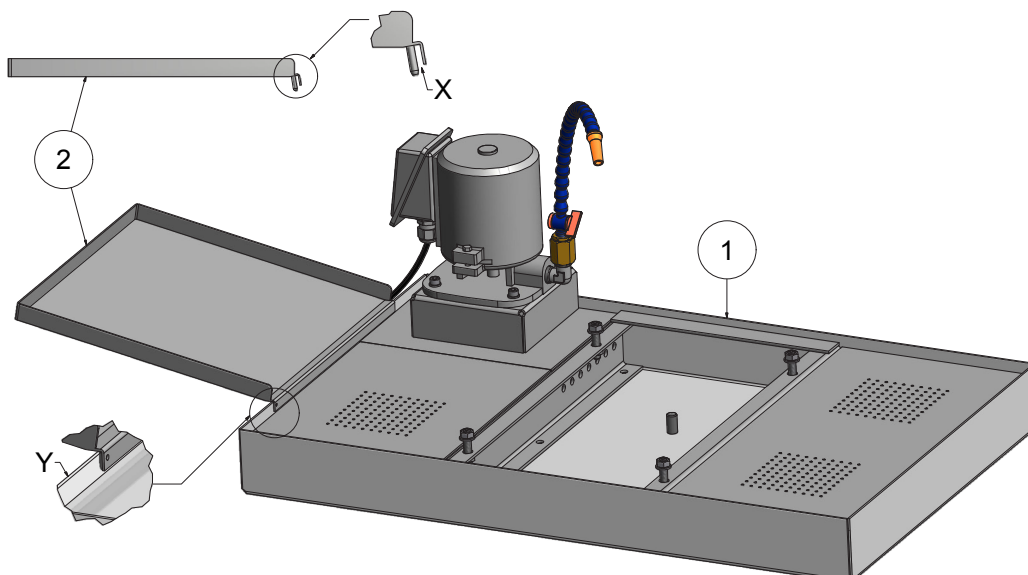

19. Coolant unit (optional)

19.4 Safety regulations for the handling of cooling lubricant

1. Pay particular attention to leaked coolant as this can quickly cause people to slip and caused accidents as a result.
2. Secure your coolant unit in such a way that it cannot be switched on by children. Persons who have not been trained may not operate the coolant unit.
3. Ensure you have a clean workplace, dirty areas can quickly lead to accidents.
4. Never use the coolant unit when processing magnesium alloys. In combination with water-mixed coolants, this may result in flammable gas mixtures which may explode under certain circumstances.
5. Avoid longer skin contact with the coolant.
6. Use skin protecting creams when handling coolants.
7. Regularly monitor the concentration of the water-mixed coolant.
8. Regularly monitor the pH value of the coolant.
9. Make sure that the coolant is only disposed of in an environmentally friendly way in accordance with the relevant guidelines. Coolant is a special waste product

19.5 Filling the coolant unit

A number of protective measures must be observed and taken in order to ensure that the handling of coolant does not cause health risks or environmental loads.

- Always observe the datasheet and the safety regulations of the coolant being used (can be obtained from the supplier or manufacturer).
- Observe all safety regulations set out in these operating instructions, in particular those that refer to the safe handling of coolants.
- In order to ensure reliable operation of the coolant pump, a minimum coolant filling level is required in the coolant tank.
- The capacity of the coolant unit is approximately 13 liters.
- The maximum filling level should be just below the shelf insert.
- The minimum filling level is approximately 15 mm below that.
- To fill, remove the shelf insert and fill to the maximum filling level with a suitable coolant whilst observing all safety regulations.
- After filling, replace the shelf insert.

19. Coolant unit (optional)

19.6 Operating the coolant unit without CNC controller

The switch shown below is located on the mains cable of the coolant pump



Switch position (0) → Pump switched off

Switch position (1) → Pump switched on

(Caution: Coolant flow is controlled with the coolant shut-off valve)

19.7 Operating the coolant unit with CNC controller

For machines with 1.4 kW drive motor

For machines with 2.0 kW (hs) drive motor

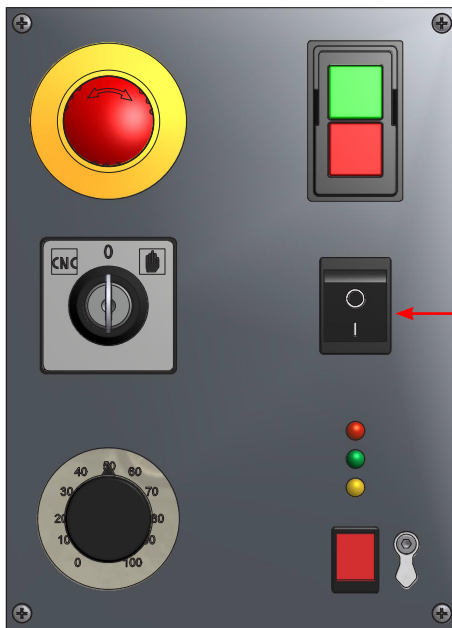

Switch for coolant pump

Switch position (0) → Pump switched off

Switch position (1) → Pump switched on

(Caution: Coolant flow is controlled with the coolant shut-off valve)

19. Coolant unit (optional)

19.8 Positioning the segmented coolant hose

The flexible segmented hose (shown in blue) is made up of individually adjustable elements and can be shaped by hand or set as required. The segmented hose and the nozzle are to be positioned in such a way that the coolant flows as directly as possible onto the blade of the cutting tool of the milling machine. Attention should be paid to ensure that the nozzle does not come into contact with the cutting tool.

19.9 Controlling the flow of coolant using the coolant shut-off valve

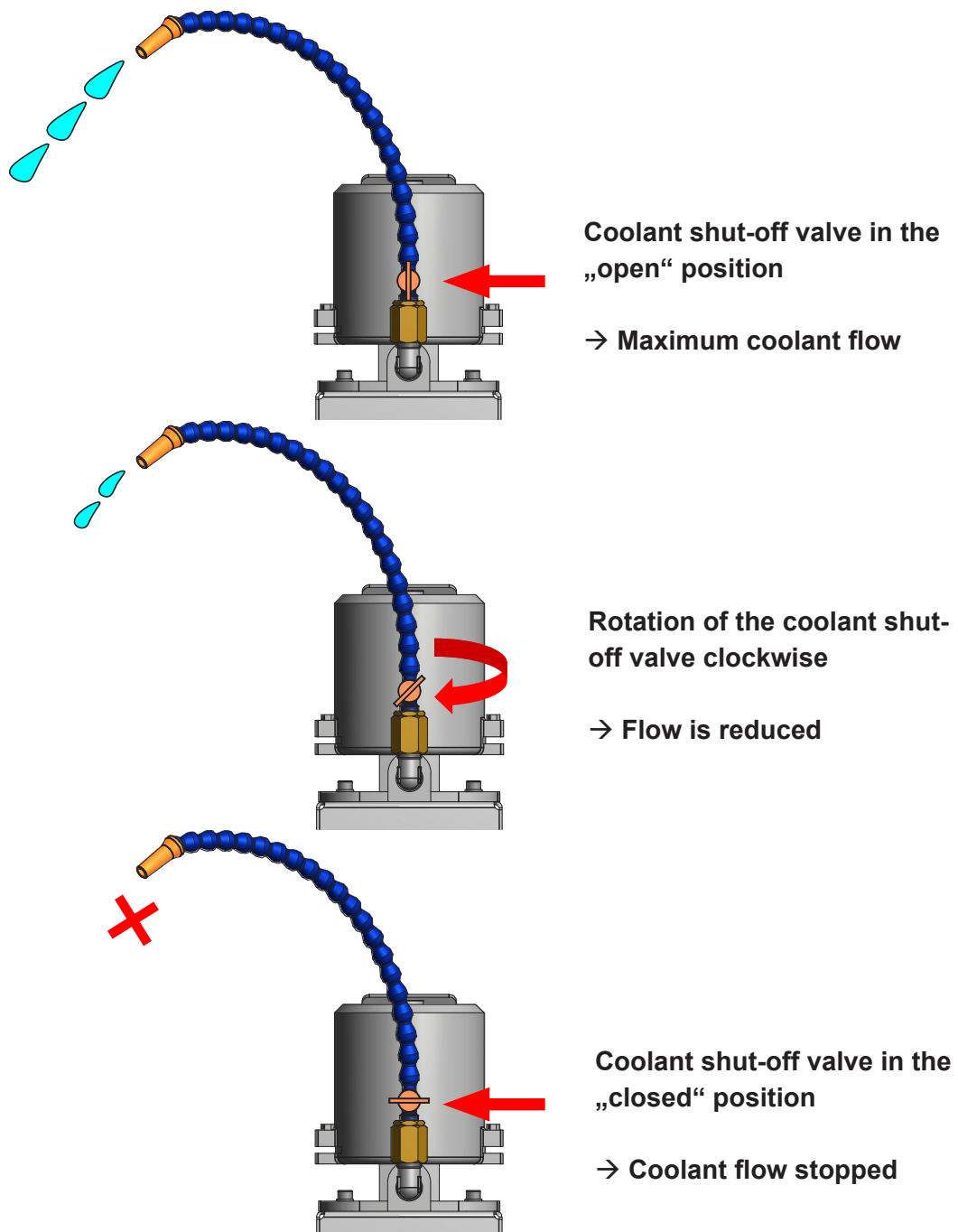

19. Coolant unit (optional)

19.10 Drawing and legend

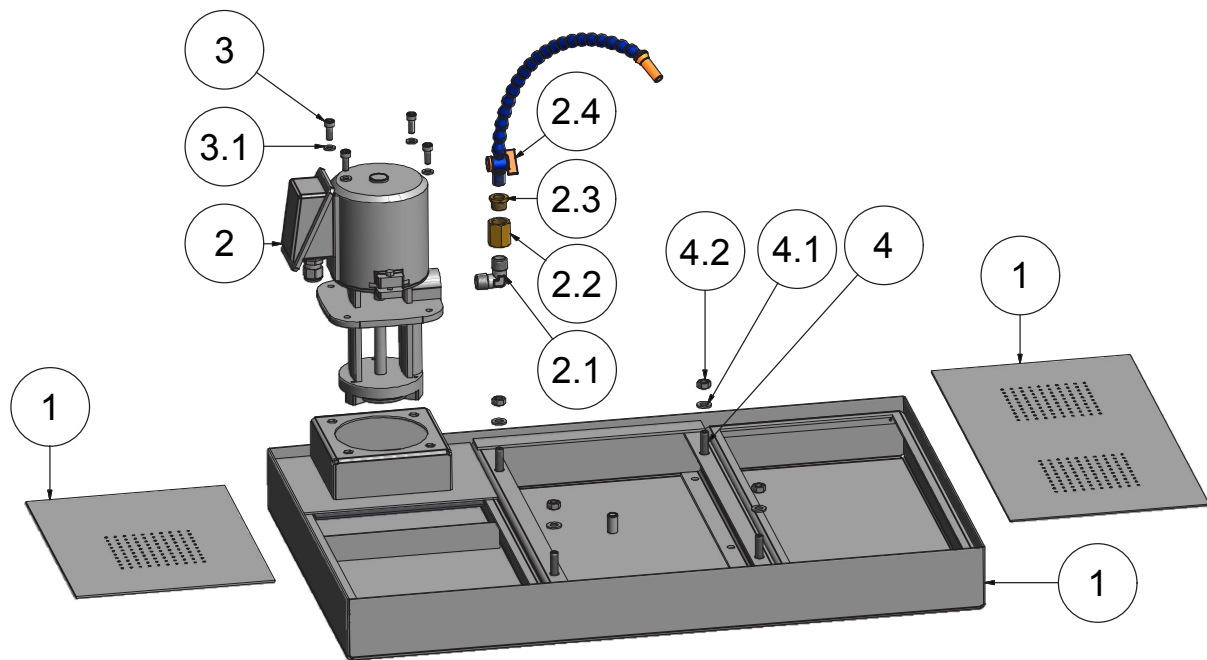

Part no.	Items	Order no.	Description
1	1	51401163-0001	Coolant unit (tank and two shelf inserts)
2	1	51500119	Coolant pump
2.1	1	51504348	Angle bracket
2.2	1	51504350	Collar
2.3	1	51504332	Reducing nipple
2.4	1	51502507	Coolant hose with shut-off valve
3	4	16191200006016	Screw
3.1	4	16112500006001	Washer
4	4	16191300008040	Threaded pin
4.1	4	16112500008001	Washer
4.2	4	16193400008000	Nut

20. Machine safety cabin (optional)

20.1 Setting up the machine safety cabin

When mounting the machine safety cabin to a WABECO machine base cabinet, the appropriate bored holes are already present. The machine base cabinet ensures a safe base for the milling machine or machine safety cabin.

If the machine safety cabin is secured to another suitable surface, the 4 through holes must be bored into the surface by the client. For the positions of the 4 fixture threaded sockets (thread M8) of the machine safety cabin, see diagram. The diameter of the through holes in the surface must be at least 9 mm.

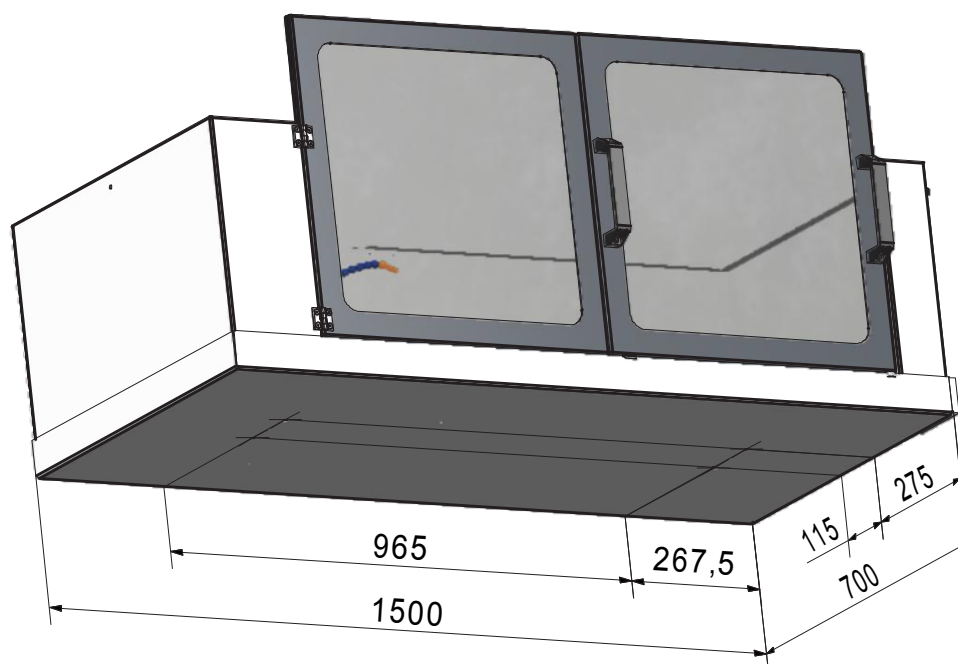

20.2 Mounting of the machine safety cabin to the machine base cabinet (optional)

- The machine safety cabin (2) is positioned, as shown, on the machine base cabinet (1).
- The screws and washers required for assembly are included in the scope of delivery.

To screw the machine safety cabin to the machine base cabinet proceed as follows:

1. Combine each screw with a washer.
2. Open the door or the machine base cabinet.
3. Push the screws from below, through the bored holes in the machine base cabinet, into the fixture threaded sockets and tighten using an Allen key of size 6.

20. Machine safety cabin (optional)

20.2 Mounting of the machine safety cabin to the machine base cabinet (optional)

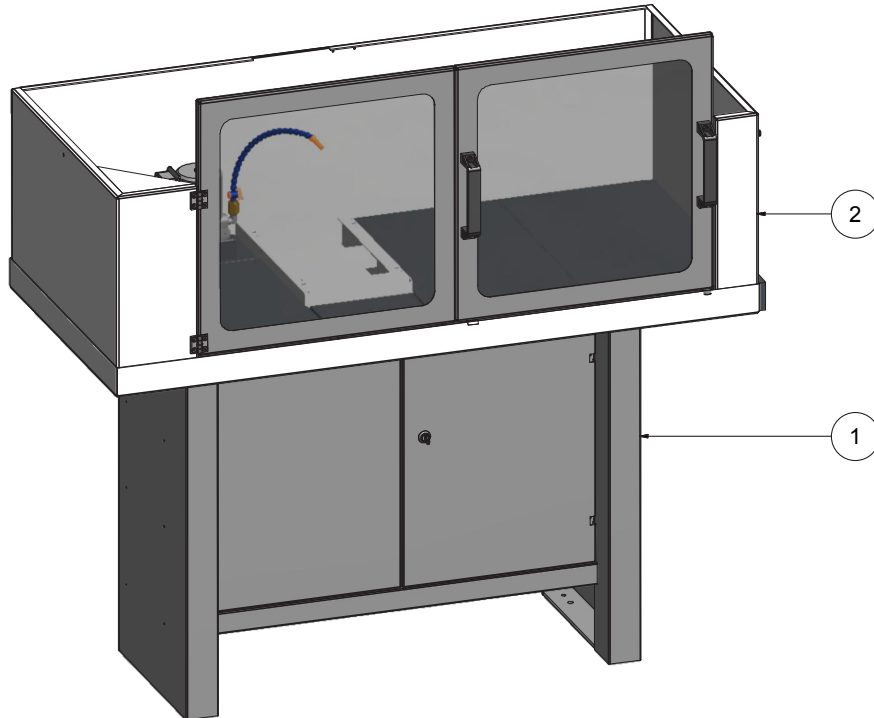

20.3 Safety regulations for the handling of cooling lubricant

See point 19.4

20.4 Filling the coolant unit integrated in the machine safety cabin

See point 19.5

The capacity of the coolant unit integrated in the machine safety cabin is approximately 42 liters.

20.5 Operating the coolant unit with CNC controller

See point 19.7

20.6 Positioning the segmented coolant hose

See point 19.8

20.7 Controlling the flow of coolant using the coolant shut-off valve

See point 19.9

20. Machine safety cabin (optional)

20.8 Drawing and legend

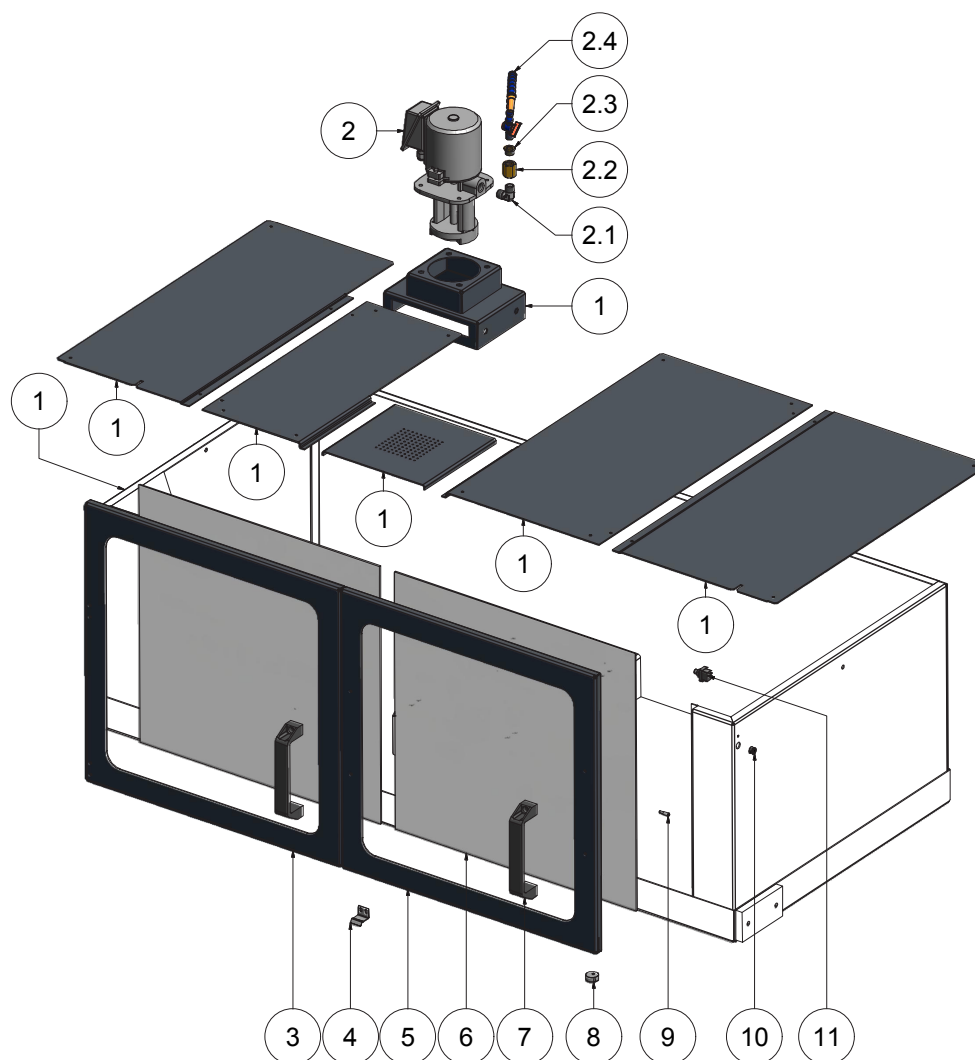

Part no.	Items	Order no.	Description
1	1	51401459-0001	Machine safety cabin (tank and six shelf inserts)
2	1	51500119	Coolant pump
2.1	1	51504348	Angle bracket
2.2	1	51504350	Collar
2.3	1	51504332	Reducing nipple
2.4	1	51502507	Coolant hose with shut-off valve
3	1	51401461-0001	Door, left
4	1	51505058	Engaging insert
5	1	51401462-0001	Door, right
6	2	51401133	Polycarbonate screen
7	2	51507006	Bar handle
8	1	51008630-0004	Glider
9	1	51004006-0003	Trigger bolt
10	1	51501531	Strain relief
11	1	51500619	Switch

21. Mounting bracket (optional)

The mounting bracket is used to accommodate drive units with a 23 mm diameter Euronorm collar. This enables the use of devices, such as drills, routers and high-frequency spindles on a WABECO milling machines.

Like the standard milling head, the mounting bracket can be swiveled by 90 degrees to the left or the right. (see chapter: “Swivel milling head”)

21.1 Mounting the mounting bracket to the milling machine

For machines that are fitted with the mounting bracket at the factory, mounting will not be required.

Attention should be paid to ensure that the index bolt, unlike the standard milling head, is attached to the right side of the mounting bracket.

If the mounting bracket is to be subsequently fitted to the machine, this will by default replace the milling head mounted on the milling machine.

To mount the mounting bracket, first remove the index bolt as described in **chapter: “Swivel milling head”**. Then fully unscrew the hexagonal screw (2) and hexagonal nut (3). The milling head can then be removed carefully and replaced by the mounting bracket.

To secure the mounting bracket, fit and screw the hexagonal screw (2) and hexagonal nut (3) back into place far enough that the mounting bracket can still be swiveled.

Then align the mounting bracket and tighten the hexagonal screw (2) and hexagonal nut (3) fully.

The index bolt for quickly aligning the milling head/mounting bracket may continue to be used. The cone boring necessary for this must be made by the client in the mounting bracket or vertical slide. For this reason, the mounting bracket has a pilot drilled hole on the right side.

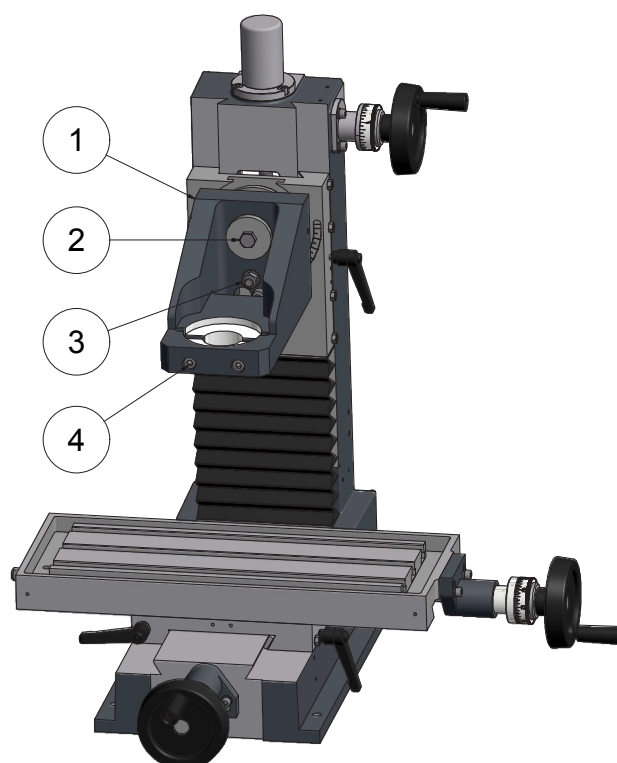

21. Mounting bracket (optional)

21.2 Inserting the drive unit into the mounting bracket

To insert a drive unit with a 43 mm diameter Euronorm collar, first undo the two clamping screws (4) of the mounting bracket. Then the drive unit can be inserted from the top with gentle backwards and forwards turns into the 43 mm diameter holding boring. Then, tighten the two clamping screws (4) and check the drive unit for correct seating

21.3 Drawing and legend

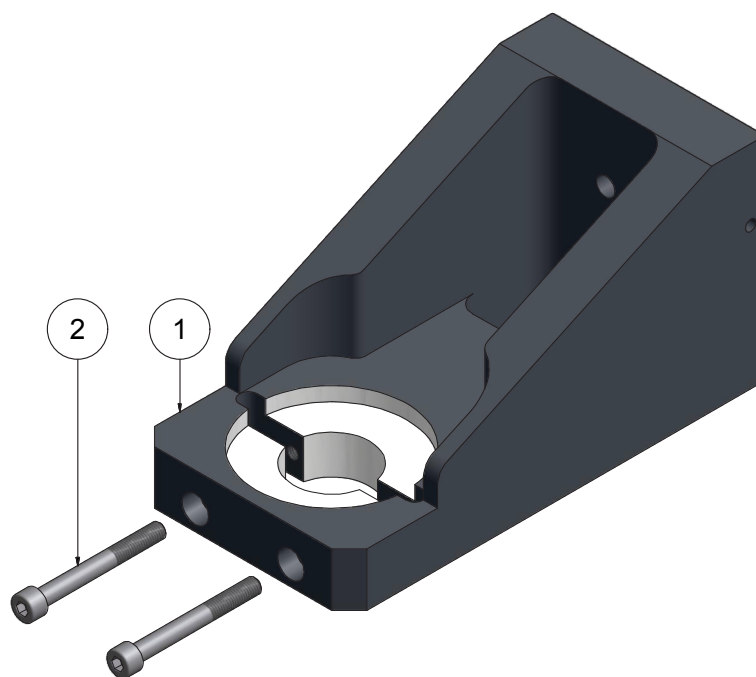

Part no.	Items	Order no.	Description
1	1	51006494-0001	Mounting bracket
2	2	16191200008070	Screw

22. NC-rotary table (optional)

The NC-rotary table is used to control the fourth axis in conjunction with nccad professional.

The housing body (1) has 4 flutes that enable the clamping of the NC-rotary table in both the vertical and the horizontal plane.

In order to be able to control the NC-rotary table with the control software, this must first be parameterised and activated in nccad professional as described in the enclosed parameter sheet.

22.1 Clamping of workpieces on the NC-rotary table

The workpiece to be processed is clamped using T-nuts or hexagonal screws in the intended T-shaped grooves of the rotary table.

When using lathe chucks, the chuck flange is clamped using T-nuts or hexagonal screws in the intended T-shaped grooves of the rotary table (2). The workpiece to be processed is, in turn, clamped in the lathe chuck

22.2 Swiveling the worm shaft in and out

The swiveling of the worm shaft in and out is not necessary in CNC mode. But if the worm shaft is accidentally (e.g. by way of collision) swiveled out, then it must be brought back into contact with the worm gear.

To set, proceed as follows:

1. Undo the locking screw (11) the eccentric tappet can now be rotated.
2. The eccentric tappet is easiest to set by swiveling the NC drive unit.
3. In order to bring the worm shaft into contact with the worm gear, the eccentric tappet must be rotated anti-clockwise (swivel the NC drive unit backwards).
4. After successfully setting, tighten up the locking screw (11) again.
5. An incorrect setting of the NC drive unit may be corrected by undoing the screw (29) and then swiveling the unit.
6. Then tighten the screw (29) again.

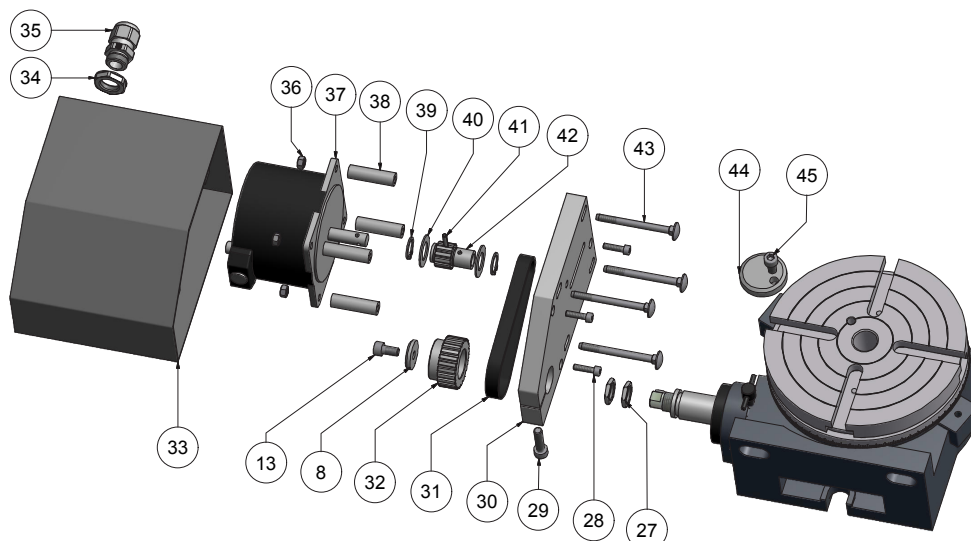

22. NC-rotary table (optional)

22.3 Setting the axial play of the NC-rotary table

The axial play of the rotary table (2) is set using the limiting ring (4)

To set, proceed as follows:

7. Undo the four threaded pins (25) in the limiting ring (4) using a 2.5 mm Allen key.
8. Tighten the four fixing screws (21) of the limiting ring using a 3 mm Allen key crosswise and medium-tight.
9. The rotary table can now be rotated using a 5 mm Allen key pushed through the motor hood into the screw (13) (only clockwise). The rotary table should only turn with difficulty or not at all.
10. The four threaded pins in the limiting ring can now be used to set the play very finely.
11. The threaded pins are tighten crosswise, in small stages, and the movement of the rotary table is constantly checked by rotating with the Allen key.
12. The play is set correctly when the rotary table can again be turned evenly without exerting considerable force.

Excess axial play of the rotary table may be the cause of dimensional deviations and bad surface qualities.

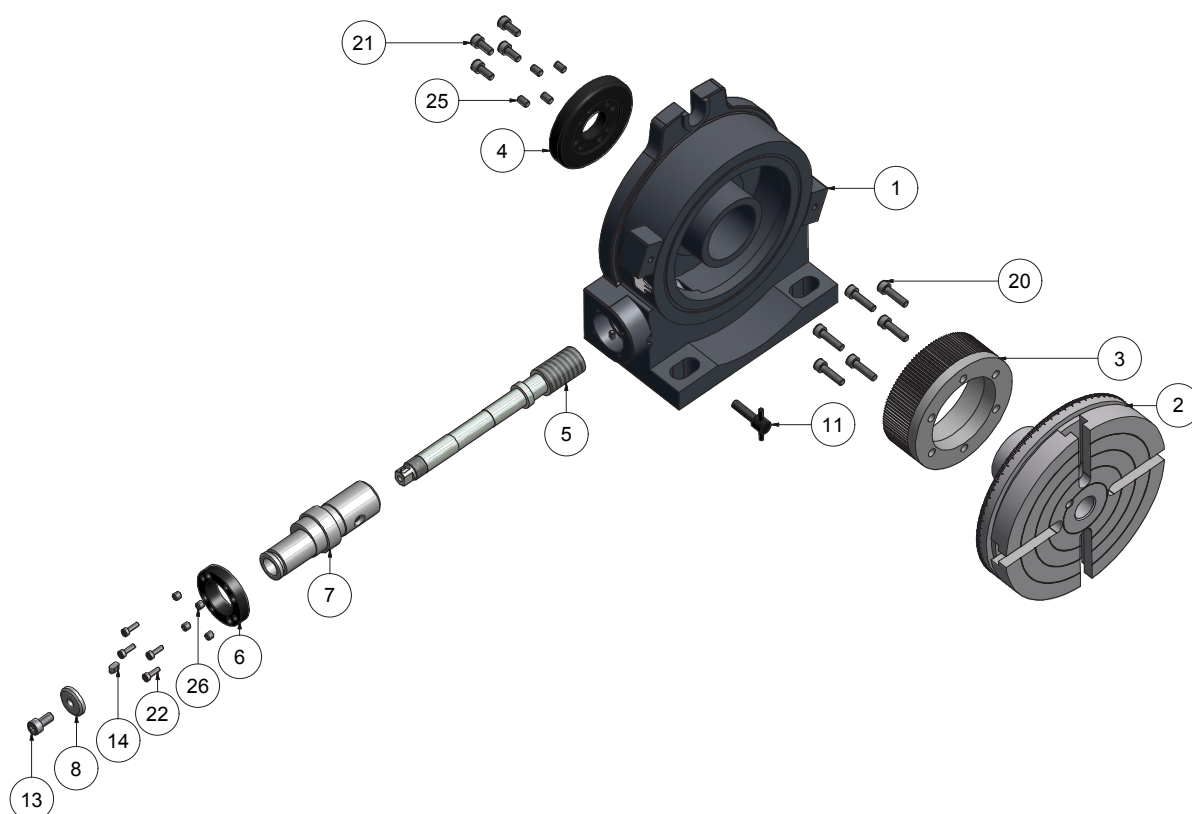

22. NC-rotary table (optional)

22.4 Removing the NC drive unit

The following adjustment work on the NC-rotary table can only be carried out with the NC drive unit removed. The following section describes the removal of the NC drive unit.

In order to mount the drive unit of the NC-rotary table after successful adjustment, carry out the same instructions in the reverse order.

1. Undo the screw (45) using a 5 mm Allen key and remove the washer (44).
2. Slightly undo the screw (29) using a 5 mm Allen key. This enables the motor holding plate (20) to be swiveled.
3. Remove the three screws (28) using the Allen key. The motor holding plate may be swiveled to give better access to the screws.
4. Tighten the screw (29) back up again.
5. Open the cable duct (35) sufficiently to allow the cables to pass through easily.
6. Remove the motor hood (33) from the motor holding plate whilst also slackening the motor cable.
7. Slightly undo the four nuts (36) using an 8 mm wrench.
8. Loosen the belt tension by moving the motor (37) and remove the toothed belt (31) from the belt pulley (32).
9. Loosen the screws (13) and remove with the washer (8).
10. Remove the belt pulley (32).
11. Undo the screw (29).
12. Remove the motor holding plate (30).

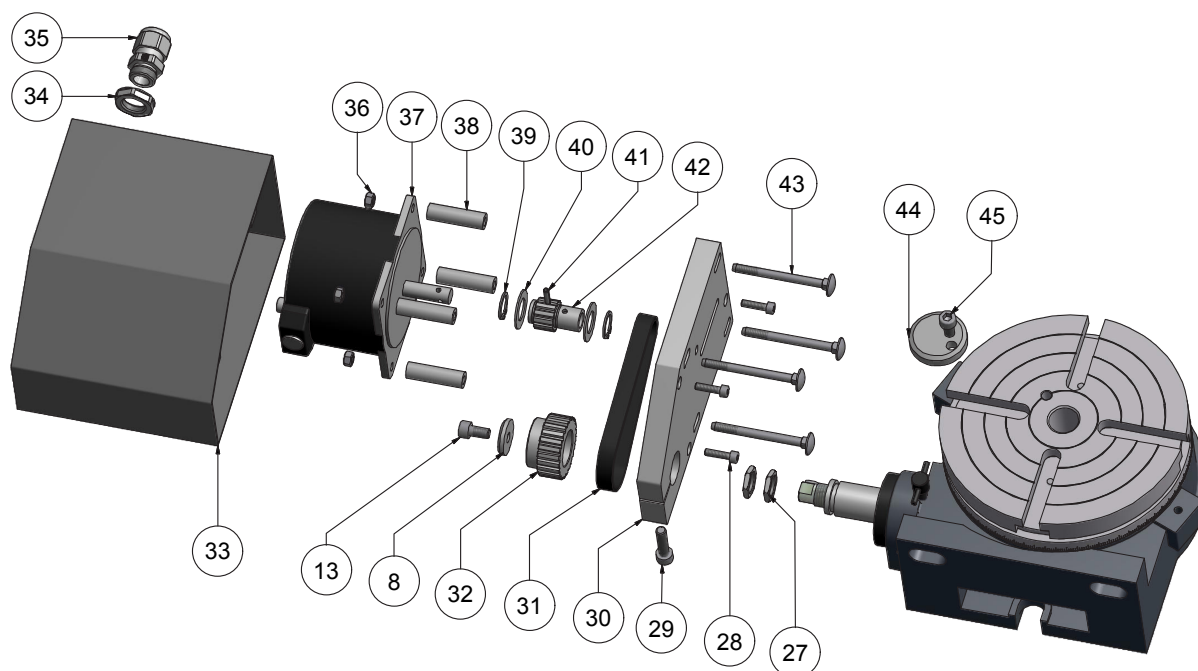

22. NC-rotary table (optional)

22.5 Setting the axial play of the worm shaft

The worm shaft (5) is in the eccentric tappet (7). The axial play of the worm shaft is set using the setting nuts (27).

To set the axial play of the worm shaft, proceed as follows:

1. Remove the NC drive unit (see chapter: "Removing the NC drive unit").
2. Open the lock by undoing the first of the two setting nuts (27) using a 17 mm wrench.
3. Depending on requirement, tighten or loosen the second setting nut (27) with the wrench.
4. Counter the first setting nut with the second.
5. After successfully completing the settings, reinstall the remaining parts in the reverse order.

22.6 Setting the axial play of the eccentric tappet

The axial play of the eccentric tappet (7) is set using the holding ring (6).

The axial play of the eccentric tappet (7) is set using the holding ring (6).

1. Remove the NC drive unit. (see chapter: "Removing the NC drive unit")
2. Undo the four threaded pins (26) in the holding ring (6) using a 2.5mm Allen key.
3. Tighten the four fixing screws (22) of the holding ring using a 2.5 mm Allen key crosswise and medium-tight.
4. With the locking screw (11) loosened, it should only be possible to swivel the eccentric tappet with difficulty or not at all.
5. The four threaded pins in the holding ring can now be used to set the play very finely.
6. Tighten the threaded pins crosswise, evenly and in small stages and constantly check the movement of the eccentric tappet.
7. The play is set correctly when the eccentric tappet can again be swiveled evenly with moderate force.
8. After successfully completing the settings, reinstall the remaining parts in the reverse order.

22. NC-rotary table (optional)

22.7 Drawing and legend

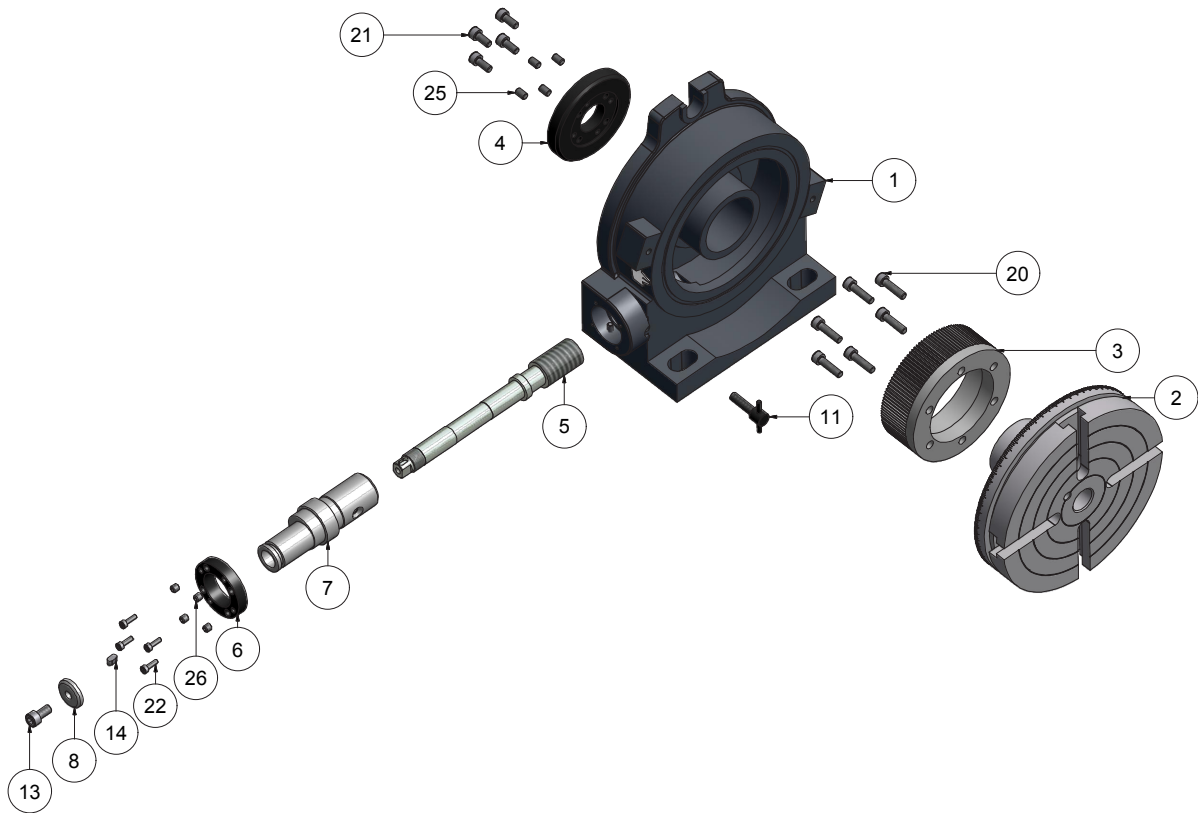

Part no.	Items	Description
1	1	Housing body
2	1	Rotary table
3	1	Worm wheel
4	1	Stop ring
5	1	Worm shaft
6	1	Retaining ring
7	1	Excenter
8	1	Washer
11	1	Locking screw
13	1	Screw
14	1	Feather key
20	6	Fixing screw worm wheel
21	4	Fixing screw stop ring
22	4	Fixing screw retaining ring
25	4	Adjustment screw retaining ring
26	4	Adjustment screw stop ring

22. NC-rotary table (optional)

22.7 Drawing and legend

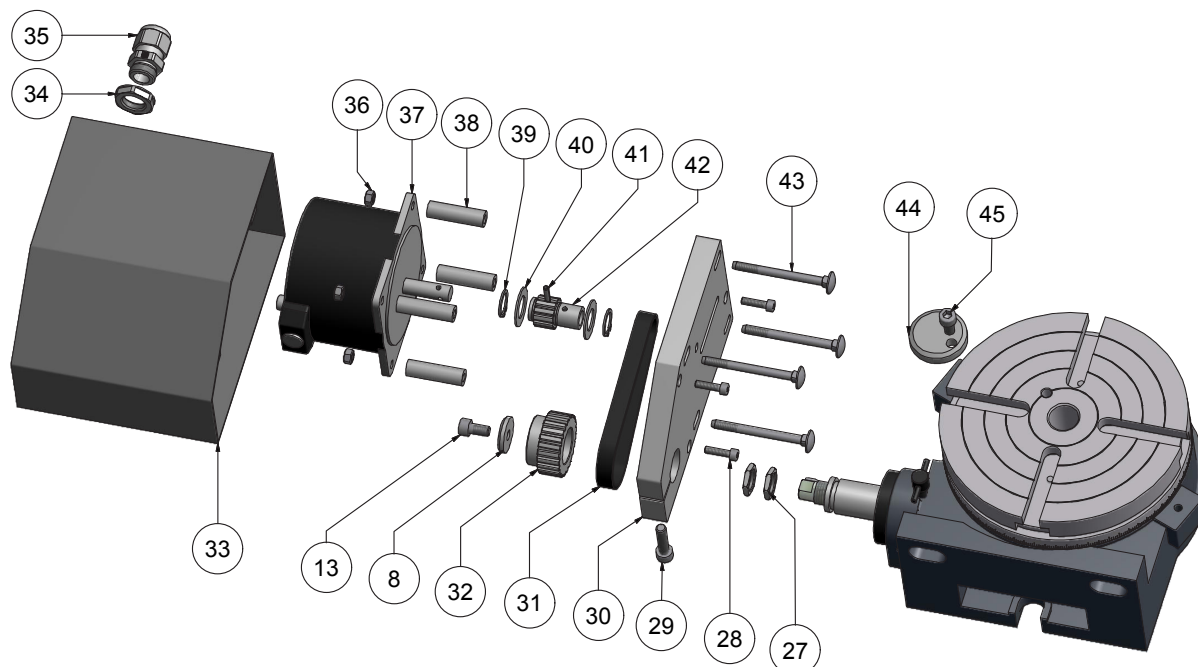

Part no.	Items	Order no.	Description
27	2	51007413-0001	Setting nut
28	3	16191200004016	Screw
29	1	16191200006025	Screw
30	1	51006291-0001	Motor plate
31	1	51502321	Gear belt
32	1	51004040-0009	Gear belt wheel
33	1	51401330-0001	Motor cover
34	1	51501505	Counter nut
35	1	51501533	Cable screw
36	4	16193400005000	Nut
37	1	51500122	Stepping motor
38	1	51004010-0021	Spacer
39	2	16047100014000	Securing ring
40	2	16000002214010	Adjusting washer
41	1	16073430003014	Spiral tensioning pin
42	1	51004020-0002	Belt disk
43	1	16160300005060	Screw
44	1	51006535-0004	Washer
45	1	16191200006012	Screw